

**Bluetooth® Class 2 OEM Module**

**Parani-BCD210  
Product Datasheet**

Version 1.0.0  
June 18, 2012

Sena Technologies, Inc

**Copyright**

Copyright [2008~2019](#), Sena Technologies, Inc. All rights reserved.

Sena Technologies reserves the right to make changes and improvements to its product without providing notice.

**Trademark**

Parani™ is a trademark of Sena Technologies, Inc.

Windows® is a registered trademark of Microsoft Corporation.

[Ethernet® is a registered trademark of XEROX Corporation.](#)

[Bluetooth® is a registered trademark of Bluetooth SIG \(Special Interest Group\).](#)

**Notice to Users**

When a system failure may cause serious consequences, protecting life and property against such consequences with a backup system or safety device is essential. The user agrees that protection against consequences resulting from system failure is the user's responsibility.

This device is not approved for life-support or medical systems.

Changes or modifications to this device not explicitly approved by Sena Technologies will void the user's authority to operate this device.

**Precautions and Safety**

Do not drop or subject the device to impact. Damage to your products may result from improper use.

Keep away from harsh environments including humid, dusty, and smoky areas. Damage to your products may result from improper use.

Do not use excessive force on the buttons or attempt to disassemble the device. Damage to your products may result from improper use.

Do not place heavy objects on the product. Damage to your products may result from improper use.

**Contact Information**

Technical support email: [support@sena.com](mailto:support@sena.com)

Company website: <http://www.sena.com>

서식 있음: 양쪽

Contents

1. General ..... 64

    1.1 Features ..... 64

    1.2 Applications ..... 75

    1.3 Device Diagram ..... 86

    1.4 Pin Diagram ..... 86

    1.5 Pin Descriptions ..... 97

    1.6 Mechanical Drawings ..... 119

    1.7 Recommended Footprint ..... 1444

    1.8 Recommended Board Layout ..... 1442

2. Electrical characteristics ..... 1512

    2.1 Absolute maximum ratings ..... 1512

    2.2 Recommended operating conditions ..... 1512

    2.3 Power Consumption ..... 1642

3. RF Characteristics ..... 1613

    3.1 Basic Data Rate ..... 1613

        3.1.1 Transmitter Performance ..... 1613

        3.1.2 Transceiver ..... 1744

        3.1.3 Receiver Performance ..... 1744

    3.2 Enhanced Data Rate ..... 1814

        3.2.1 Transmitter performance ..... 1814

        3.2.2 Receiver performance ..... 1815

4. Device Terminal Descriptions ..... 1946

    4.1 UART Interface ..... 2046

    4.2 USB Interface ..... 2117

    4.3 I<sup>2</sup>C Interface ..... 2147

    4.4 PCM CODEC Interface ..... 2218

    4.5 I/O Parallel Ports ..... 2248

    4.6 Reset Interface ..... 2319

- 서식 있음: 글꼴: 굵게 없음
- 서식 있음: 글꼴: 굵게 없음
- 서식 있음: 글꼴: Arial, 굵게 없음
- 서식 있음: 글꼴: Arial, 굵게 없음
- 서식 있음: 글꼴: Arial, 굵게 없음
- 서식 있음: 글꼴: Arial, 굵게 없음
- 서식 있음: 글꼴: Arial, 굵게 없음
- 서식 있음: 글꼴: Arial, 굵게 없음
- 서식 있음: 글꼴: Arial, 굵게 없음
- 서식 있음: 글꼴: Arial, 굵게 없음
- 서식 있음: 글꼴: Arial, 굵게 없음
- 서식 있음: 글꼴: Arial, 굵게 없음
- 서식 있음: 글꼴: Arial, 굵게 없음
- 서식 있음: 들여쓰기: 첫 줄: 0 글자
- 서식 있음: 글꼴: 굵게 없음
- 서식 있음: 글꼴: 굵게 없음
- 서식 있음: 글꼴: 굵게 없음
- 서식 있음: 들여쓰기: 첫 줄: 0 글자
- 서식 있음: 글꼴: 굵게 없음
- 서식 있음: 글꼴: 굵게 없음
- 서식 있음: 글꼴: 굵게 없음
- 서식 있음: 글꼴: 굵게 없음
- 서식 있음: 글꼴: 굵게 없음
- 서식 있음: 양쪽

<u>5. Application Schematic.....</u>	<u>2319</u>	서식 있음: 글꼴: 굵게 없음
<u>6. Software Stack.....</u>	<u>2822</u>	서식 있음: 글꼴: 굵게 없음
<u>7. Solder Profiles .....</u>	<u>2924</u>	서식 있음: 글꼴: 굵게 없음
<u>8. Packaging Information .....</u>	<u>3025</u>	서식 있음: 글꼴: 굵게 없음
<u>9. Certificate Information.....</u>	<u>3226</u>	서식 있음: 글꼴: 굵게 없음
<u>9.1 FCC .....</u>	<u>3226</u>	서식 있음: 글꼴: 굵게 없음
<u>9.2 CE.....</u>	<u>3327</u>	서식 있음: 글꼴: 굵게 없음
<u>9.3 IC .....</u>	<u>3328</u>	서식 있음: 글꼴: 굵게 없음
<u>9.4 KC.....</u>	<u>3328</u>	서식 있음: 글꼴: 굵게 없음
<u>9.5 TELEC .....</u>	<u>3328</u>	서식 있음: 글꼴: 굵게 없음
<u>9.6 SIG .....</u>	<u>3328</u>	서식 있음: 글꼴: 굵게 없음
<u>1. General .....</u>	<u>4</u>	서식 있음: 목차 1, 수준 3, 들여쓰기: 왼쪽: 0 cm, 탭: 5 글자(없음)
<u>1.1 Features .....</u>	<u>4</u>	서식 있음: 수준 2
<u>1.2 Applications .....</u>	<u>4</u>	
<u>1.3 Device Diagram .....</u>	<u>5</u>	서식 있음: 수준 3
<u>1.4 Pin Diagram .....</u>	<u>5</u>	
<u>1.5 Pin Descriptions.....</u>	<u>6</u>	
<u>1.6 Dimensions and PCB land pattern .....</u>	<u>7</u>	
<u>2. Electrical characteristics .....</u>	<u>8</u>	
<u>2.1 Absolute maximum ratings .....</u>	<u>8</u>	
<u>2.2 Recommended operating conditions .....</u>	<u>8</u>	
<u>2.3 Power Consumptions .....</u>	<u>8</u>	
<u>3. RF Characteristics .....</u>	<u>9</u>	
<u>3.1 Basic Data Rate .....</u>	<u>9</u>	
<u>3.1.1 Transmitter Performance .....</u>	<u>9</u>	서식 있음: 수준 3
<u>3.1.2 Transceiver .....</u>	<u>9</u>	
<u>3.1.3 Receiver Performance .....</u>	<u>9</u>	
<u>3.2 Enhanced Data Rate .....</u>	<u>10</u>	서식 있음: 수준 3
<u>3.2.1 Transmitter performance .....</u>	<u>10</u>	
<u>3.2.2 Receiver performance .....</u>	<u>11</u>	
<u>4. Device Terminal Descriptions .....</u>	<u>12</u>	서식 있음: 수준 3
<u>4.1 UART Interface .....</u>	<u>12</u>	
<u>4.2 USB Interface .....</u>	<u>12</u>	
<u>4.3 I2C Interface .....</u>	<u>13</u>	
<u>4.4 PCM CODEC Interface .....</u>	<u>13</u>	
<u>4.5 I/O Parallel Ports .....</u>	<u>14</u>	
<u>4.6 Reset Interface .....</u>	<u>14</u>	서식 있음: 양쪽

5. Application Schematic..... 15

6. Software Stack..... 18

7. Solder Profiles ..... 19

8. Packaging Information..... 20

9. Certificate Information..... 22

9.1 Bluetooth SIG Certification..... 22

서식 있음: 양쪽

1.4. General

The Parani-BCD210 is a Bluetooth Class 2 OEM module for OEM manufacturers who want to implement Bluetooth Class 2 functionality with their products cost effectively and also in timely manner. By using Parani-BCD210, users can add low cost Bluetooth functionality to their products easily and quickly while keeping the benefit from the BCD210's field-proven standard SPP (Serial Port Profile) firmware provided with no additional cost.

The BCD210 supports Class 2 Bluetooth transmission level for short communication distance typically ranges from 50 m up to 300m. The BCD210 supports UART, USB, I2C, PCM, PIO interfaces for the communication with the OEM products.

The BCD210 is provided with Bluetooth v2.0 compatible firmware runs internally for SPP (Serial Port Profile) applications by default. The SPP firmware supports up to 4 simultaneous multiple connections and is designed to work out-of-box for real world SPP applications such as POS (Point-of-sales), industrial automation, remote metering and other various applications. Optionally, the BCD210 can be supplied with only software stack up to HCI level so entire Bluetooth stack runs on the host side for the application such as USB dongles for computers, or OEM manufacturers can even develop and embed their own firmware into the BCD210.

The BCD210 is fully qualified with Bluetooth v.2.0+EDR specification so OEM manufacturers can save cost and time for overall OEM product certifications, which makes the BCD210 ideal solution for larger volume and cost sensitive applications.

1.1 Features

- Bluetooth Class 2
- Bluetooth v2.0+EDR specification
- Transmit Power: +4dBm Typical
- Receive sensitivity: -84dBm (0.1% BER)
- Integrated 8Mbit Flash Memory
- Supports Serial Port Profile (SPP)
- Working distance (In an open field): Nom.50m, up to 300m
- Supports built-in chip, stub and dipole antennas
- Standard HCI over UART or USB
- Field-proven SPP (Serial Port Profile) firmware supporting up to 4 simultaneous multiple connections
- Firmware upgrade via windows-based software (Parani Updater)
- Easy to use Windows configuration tool available
- ROHS compliant

서식 있음 ... [1]

서식 있음: 제목 1

서식 있음: 글꼴: 10 pt, 밑줄 없음, 글꼴 색: 자동

서식 있음: 들여쓰기: 첫 줄: 0 글자, 지정한 문자 수에 맞춰 오른쪽 들여쓰기 자동 조정

서식 있음: 글꼴: 10 pt

서식 있음: 글꼴: 10 pt, 밑줄 없음, 글꼴 색: 자동

서식 있음: 들여쓰기: 첫 줄: 0 글자

서식 있음: 글꼴: 10 pt

서식 있음 ... [2]

서식 있음 ... [3]

서식 있음: 제목 2

서식 있음 ... [4]

서식 있음 ... [5]

서식 있음 ... [6]

서식 있음 ... [7]

서식 있음 ... [8]

서식 있음 ... [9]

서식 있음 ... [10]

서식 있음 ... [11]

서식 있음 ... [12]

서식 있음 ... [13]

서식 있음 ... [14]

서식 있음 ... [15]

서식 있음 ... [16]

서식 있음: 양쪽

1.2 Applications

- High-speed Data Transceiver Systems for Short distance communication
- PCs/Personal Digital Assistants (PDA)
- Bluetooth USB Dongle
- Bluetooth Serial Dongle
- Bluetooth Access Points
- Industrial automation device
- Remote metering device
- POS (Point-of-sales) devices

- 서식 있음: 제목 2, 지정한 문자 수에 맞춰 오른쪽 들여쓰기 자동 조정
- 서식 있음: 글꼴: (영어) Arial, 10 pt, 밑줄 없음, 글꼴 색: 자동
- 서식 있음: 글꼴: (영어) Arial, 10 pt
- 서식 있음: 글꼴: (영어) Arial, 10 pt, 밑줄 없음, 글꼴 색: 자동
- 서식 있음: 글꼴: (영어) Arial, 10 pt
- 서식 있음: 글꼴: (영어) Arial, 10 pt, 밑줄 없음, 글꼴 색: 자동
- 서식 있음: 글꼴: (영어) Arial, 10 pt
- 서식 있음: 글꼴: (영어) Arial, 10 pt, 밑줄 없음, 글꼴 색: 자동
- 서식 있음: 글꼴: (영어) Arial, 10 pt
- 서식 있음: 글꼴: (영어) Arial, 10 pt, 밑줄 없음, 글꼴 색: 자동
- 서식 있음: 글꼴: (영어) Arial, 10 pt
- 서식 있음: 글꼴: (영어) Arial, 10 pt, 밑줄 없음, 글꼴 색: 자동
- 서식 있음: 글꼴: (영어) Arial, 10 pt
- 서식 있음: 글꼴: (영어) Arial, 10 pt, 밑줄 없음, 글꼴 색: 자동
- 서식 있음: 글꼴: (영어) Arial, 10 pt
- 서식 있음: 글꼴: (영어) Arial, 10 pt, 밑줄 없음, 글꼴 색: 자동
- 서식 있음: 글꼴: 10 pt

서식 있음: 양쪽

1.3 Device Diagram

**SENA**  
Bluetooth Serial Module II  
Model: Parani-BCD210

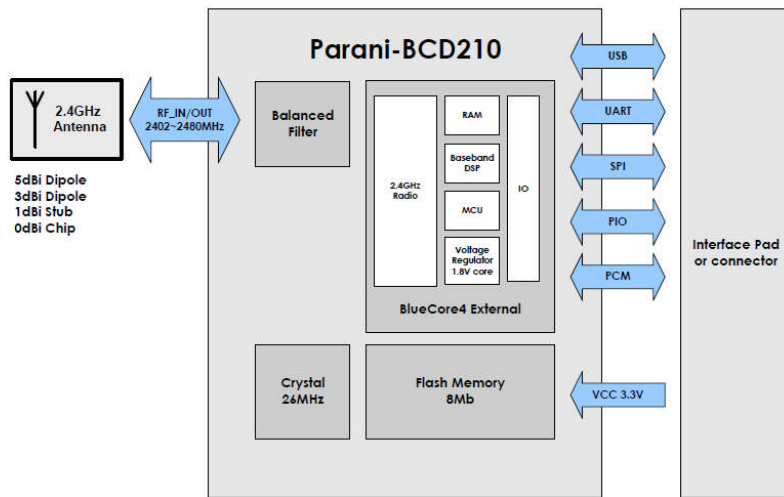

서식 있음: 제목 2

1.4 Pin Diagram

서식 있음: 제목 2

서식 있음: 양쪽



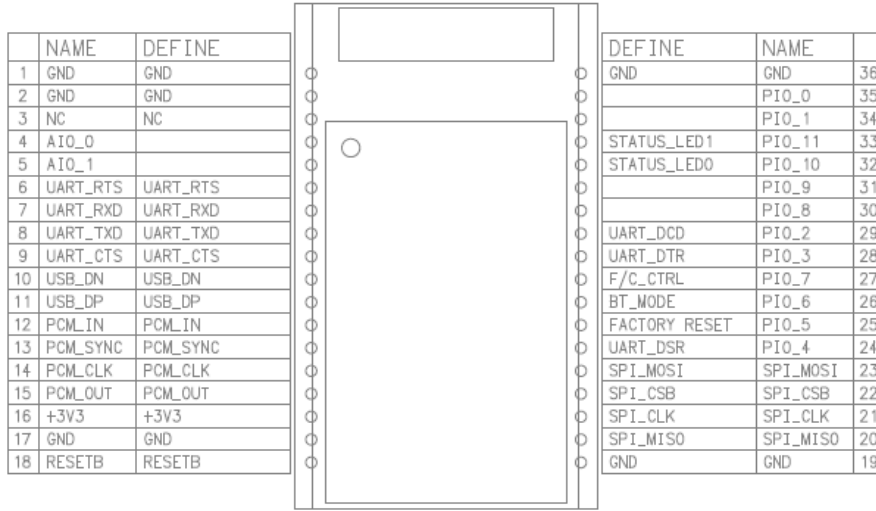

1.5 Pin Descriptions

Function	Pin Name	Pin Number	Description
USB	USB_DP	11	USB data plus
	USB_DN	10	USB data minus
UART	UART_TXD	8	UART data output
	UART_RXD	7	UART data input
	UART_RTS	6	UART request to send active low
	UART_CTS	9	UART clear to send active low
PCM	PCM_OUT	15	Synchronous data output
	PCM_IN	12	Synchronous data input
	PCM_SYNC	13	Synchronous data sync
	PCM_CLK	14	Synchronous data clock
SPI	SPI_MISO	20	SPI data output
	SPI_MOSI	23	SPI data input
	SPI_CSB	22	Chip select for SPI, active low
	SPI_CLK	21	SPI clock
PIO	PIO_0	35	Programmable input/output line
	PIO_1	34	Programmable input/output line
	PIO_2	29	Programmable input/output line
	PIO_3	28	Programmable input/output line

서식 있음: 제목 2

서식 있음: 양쪽

	PIO_4	24	Programmable input/output line
	PIO_5	25	Programmable input/output line
	PIO_6	26	Programmable input/output line
	PIO_7	27	Programmable input/output line
	PIO_8	30	Programmable input/output line
	PIO_9	31	Programmable input/output line
	PIO_10	32	Programmable input/output line
	PIO_11	33	Programmable input/output line
<b>AIO</b>	AIO_0	4	Analogue programmable input/output line
	AIO_1	5	Analogue programmable input/output line
<b>Power</b>	+3V3	16	Power supply for system, 3.3V
	GND	1,2,17,19,36	Ground
<b>Others</b>	RESETB	18	Reset, active low, > 5ms to cause a reset
	NC	3	NC

Table 1-1 Pin descriptions

Function	Pin Name	STATE		
		Define (SPP)	Direction	Pull-up/down
<b>USB</b>	USB_DP	-	Input	Weak pull-up
	USB_DN	-	Input	Weak pull-up
<b>UART</b>	UART_TXD	UART_TXD	Output	Tri-stated with weak pull-up
	UART_RXD	UART_RXD	Input	Weak pull-down
	UART_RTS	UART_RTS	Output	Tri-stated with weak pull-up
	UART_CTS	UART_CTS	Input	Weak pull-down
<b>PCM</b>	PCM_OUT	-	Output	Tri-stated with weak pull-down
	PCM_IN	-	Input	Weak pull-down
	PCM_SYNC	-	Input	Weak pull-down
	PCM_CLK	-	Input	Weak pull-down
<b>SPI</b>	SPI_MISO	-	Output	Tri-stated with weak pull-down
	SPI_MOSI	-	Input	Weak pull-down
	SPI_CSB	-	Input	Weak pull-up
	SPI_CLK	-	Input	Weak pull-down
<b>PIO</b>	PIO_0	-	Input	Weak pull-down
	PIO_1	-	Input	Weak pull-down

서식 있음: 양쪽

	PIO_2	UART_DCD	Output	Weak pull-down
	PIO_3	UART_DTR	Output	Weak pull-down
	PIO_4	UART_DSR	Input	Weak pull-up
	PIO_5	FACTORY_RESET	Input	Weak pull-up
	PIO_6	BT_MODE	Input	Weak pull-up
	PIO_7	F/C_CTRL	Output	Weak pull-up
	PIO_8	-	Input	Weak pull-down
	PIO_9	-	Input	Weak pull-down
	PIO_10	STATUS_LED0	Output	Weak pull-down
	PIO_11	STATUS_LED1	Output	Weak pull-down
AIO	AIO_0	-	Output	Driving low
	AIO_1	-	Output	Driving low
Others	RESETB	RESETB	Input	Weak pull-up

Table 1-2 Pin State on Reset

1.6 Mechanical Drawings

서식 있음: 제목 2  
 서식 있음: 글꼴: (영어) 바탕, (한글) 바탕, 10 pt, 굵게 없음, (Intl) Times New Roman

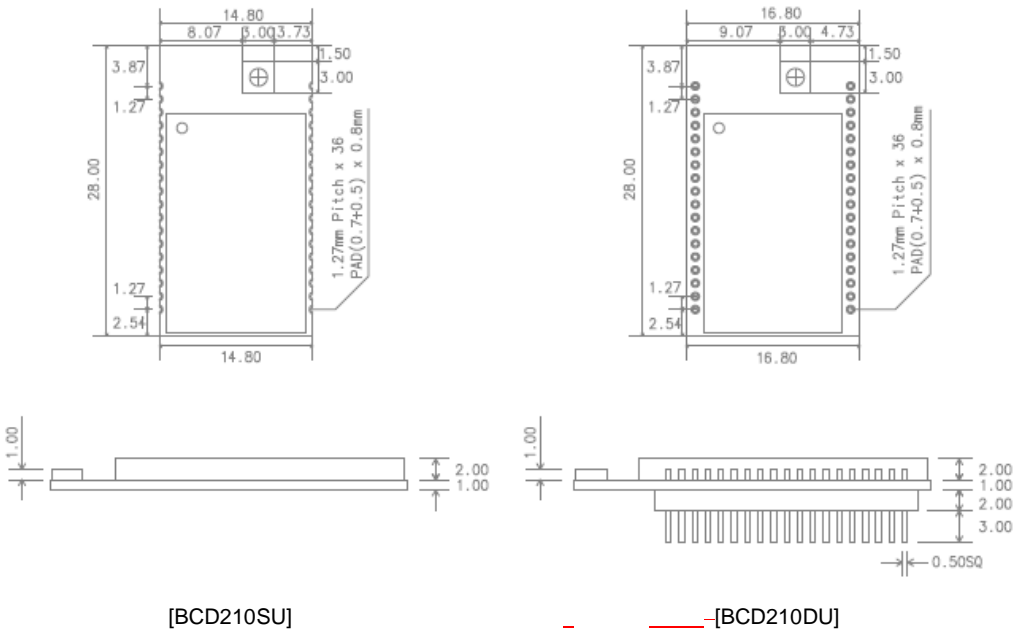

서식 있음: 가운데, 들여쓰기: 첫 줄: 0 글자  
 서식 있음: 양쪽

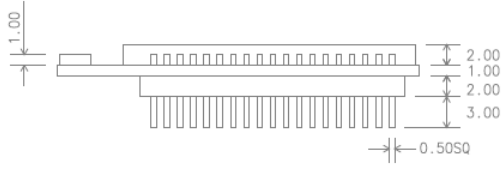
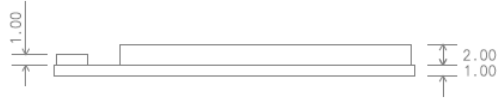
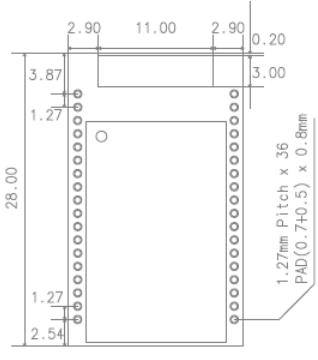
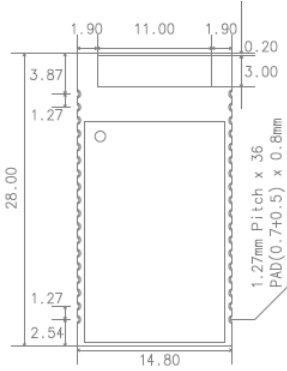

[BCD210SC]

[BCD210DC]

서식 있음: 양쪽

서식 있음: 양쪽, 들여쓰기: 첫 줄: 1 글자

서식 있음: 양쪽, 들여쓰기: 첫 줄: 9.5 글자

서식 있음: 양쪽

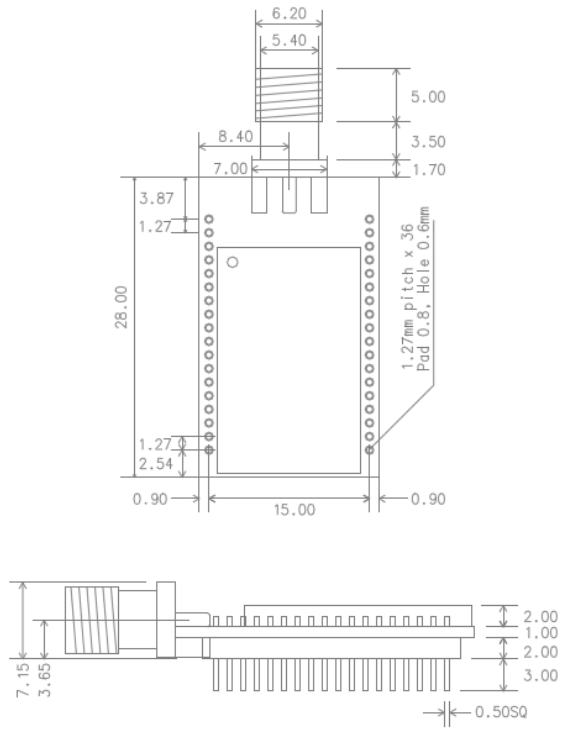

[BCD210DS]

서식 있음: 양쪽

1.7 Recommended Footprint

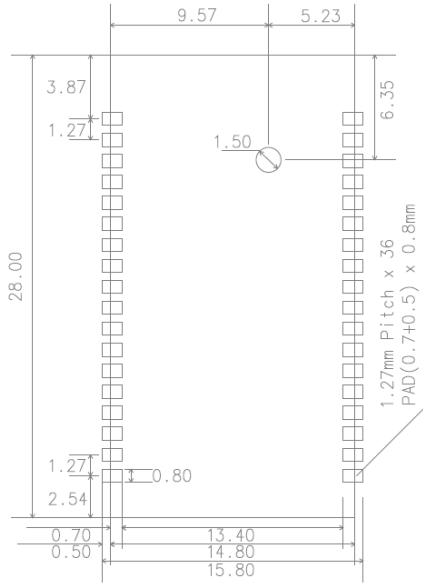

[BCD210SU, SC] \_\_\_\_\_

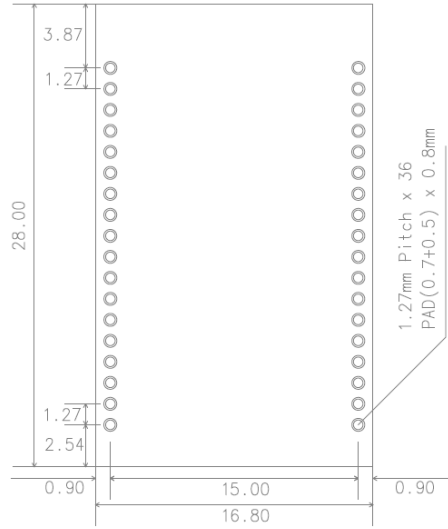

[BCD210DU, DC, DS]

서식 있음: 제목 2

서식 있음: 들여쓰기: 첫 줄: 7 글자

1.8 Recommended Board Layout

서식 있음: 제목 2

서식 있음: 글꼴: (영어) 바탕, (한글) 바탕, 10 pt, 굵게 없음, (Intl) Times New Roman

서식 있음: 양쪽

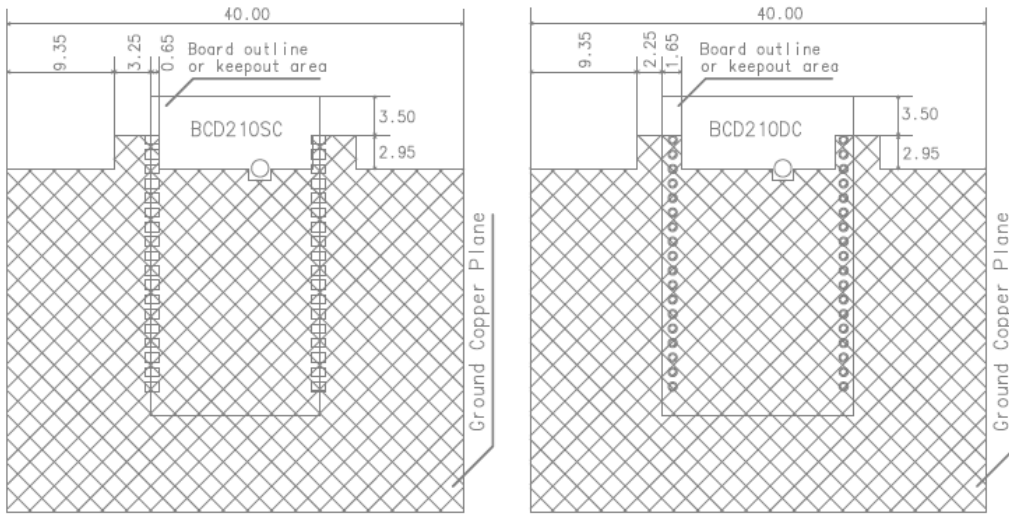

[BCD210SC]

[BCD210DC]

\*BCD210SU, DU, DS has no keep-out area.

## 2. Electrical characteristics

### 2.1 Absolute maximum ratings

Ratings	Min	Max	Unit
Storage Temperature	-40	+85	°C
Operating Temperature	-40	+85	°C
Supply voltage	-0.4	3.6	V
Other terminal voltages	GND - 0.4	VCC + 0.4	V

### 2.2 Recommended operating conditions

Ratings	Min	Typ	Max	Unit	
Operating Temperature	-40	25	+85	°C	
Supply voltage	+3V3	2.7	3.3	3.6	V
	UART	3.0	3.3	3.6	V
	USB	3.1	3.3	3.6	V
Supply current	+3V3	60	80	100	mA

서식 있음: 들여쓰기: 첫 줄: 9 글자

서식 있음: 제목 1

서식 있음: 글꼴: (영어) Arial, (한글) 돋움, 12 pt, 굵게, 밑줄 없음, 글꼴 색: 자동

서식 있음: 제목 2

서식 있음: 글꼴: (영어) Arial, (한글) 돋움, 12 pt, 굵게

서식 있음: 제목 2

서식 있음: 양쪽

2.3 Power Consumption

Operation Mode	Connection Type	UART Rate (Kbps)	Current (Average)	Unit
Power on (Standby)	-	115.2	1.4	mA
Inquiry Scan	-	115.2	42	mA
Connected (No data)	Slave	115.2	21	mA
Connected (File transfer)	Slave	115.2	29	mA
Connected (No data)	Master	115.2	5	mA
Connected (File transfer)	Master	115.2	28	mA
Sniff Mode	Master	115.2	1.7	mA

서식 있음: 제목 2

3. RF Characteristics

3.1 Basic Data Rate

3.1.1 Transmitter Performance

RF Characteristics VCC = 3.3V, 25°C	Min	Typ	Max	Bluetooth Specification	Unit	
Output power	0	2	4	4	dBm	
Power Density	0	2	4	4	dBm	
Power Control	3	4	6	2 ≤ step ≤ 8	dB	
TX Output Spectrum-Frequency range	2402	-	2480	2400 ~2483.5	MHz	
TX Output Spectrum-20dB Bandwidth	-	900	-	≤ 1000	kHz	
Adjacent Channel Power	F = F <sub>0</sub> ± 2MHz	-	-	-20	≤ -20	dBm
	F = F <sub>0</sub> ± 3MHz	-	-	-40	≤ -40	dBm
	F = F <sub>0</sub> ± > 3MHz	-	-	-40	≤ -40	dBm
Modulation	Δf <sub>avg</sub>	140	165	175	140 ≤ Δf <sub>avg</sub> ≤ 175	kHz

서식 있음: 제목 1

서식 있음: 제목 2

서식 있음: 글꼴: (영어) 바탕, (한글) 바탕, 10 pt, 굵게 없음, (Intl) Times New Roman

서식 있음: 글꼴: 10 pt, 밑줄 없음, 글꼴 색: 자동

서식 있음: 글꼴: 10 pt

서식 있음: 제목 3, 들여쓰기: 왼쪽: 0 cm, 내어쓰기: 3.93 글자

서식 있는 표

서식 있음: 왼쪽

서식 있는 표

서식 있음: 왼쪽

서식 있는 표

서식 있음: 양쪽



Characteristics	$\Delta f_{2avg}$	115	155	-	$\Delta f_{2avg} \geq 115$	kHz
	$\Delta f_{2avg}/\Delta f_{1avg}$	0.80	0.95	-	$(\Delta f_{1avg}/\Delta f_{2avg}) \geq 0.8$	-
Initial Carrier Frequency Tolerance		-20	-	20	$\leq \pm 75$	kHz
Carrier Frequency Drift	Drift rate	-20	-	20	$\leq \pm 20$	kHz/50 $\mu$ s
	1 slot Freq Drift	-25	-	25	$\leq \pm 25$	kHz
	5 slot Freq Drift	-40	-	40	$\leq \pm 40$	kHz

서식 있음: 왼쪽

서식 있는 표

3.1.2 Transceiver

RF Characteristics VCC = 3.3V, 25°C RF Characteristics VCC = 3.3V, 20°C		Min	Typ	Max	Bluetooth Specification	Unit
Out of band Spurious Emissions	0.030-1.000GHz	-36	-	-	$\leq -36$	dBm
	1.000-12.75GHz	-30	-	-	$\leq -30$	dBm
	1.800-5.100GHz	-47	-	-	$\leq -47$	dBm
	5.100-5.300GHz	-47	-	-	$\leq -47$	dBm

서식 있음: 글꼴: 10 pt, 밑줄 없음, 글꼴 색: 자동

서식 있음: 제목 3, 들여쓰기: 왼쪽: 0 cm, 내어쓰기: 3.93 글자

서식 있음: 글꼴: 10 pt

서식 있는 표

서식 있음: 왼쪽

3.1.3 Receiver Performance

RF Characteristics VCC = 3.3V, 25°C RF Characteristics VCC = 3.3V, 20°C		Min	Typ	Max	Bluetooth Specification	Unit
Sensitivity - Single slot packets (0.1%)		-	-84	-70	$\leq -70$	dBm
Sensitivity - Multi slot packets (0.1%)		-	-84	-70	$\leq -70$	dBm
C/I performance at 0.1% BER	co-channel	-	-	11	$\leq -11$	dB
	F = F <sub>0</sub> + 1MHz	-	-	0	$\leq 0$	kHz
	F = F <sub>0</sub> - 1MHz	-	-	0	$\leq 0$	dB
	F = F <sub>0</sub> + 2MHz	-	-	-20	$\leq -20$	dB
	F = F <sub>0</sub> - 2MHz	-	-	-30	$\leq -30$	dB
	F = F <sub>0</sub> - 3MHz	-	-	-40	$\leq -40$	dB
	F = F <sub>0</sub> + 5MHz	-	-	-40	$\leq -40$	dB
	F = F <sub>image</sub>	-	-	-9	$\leq -9$	dB
Blocking performance	0.030-2.000GHz	-10	-	-	-10	dBm
	2.000-2.400GHz	-27	-	-	-27	dBm
	2.500-3.000GHz	-27	-	-	-27	dBm
	3.000-12.75GHz	-10	-	-	-10	dBm
Inter-modulation performance		-39	-	-	$\geq -39$	dBm
Maximum input level at 0.1% BER		-20	-	-	$\geq -20$	dBm

서식 있음: 글꼴: 10 pt, 밑줄 없음, 글꼴 색: 자동

서식 있음: 제목 3, 들여쓰기: 왼쪽: 0 cm, 내어쓰기: 3.93 글자

서식 있음: 글꼴: 10 pt

서식 있는 표

서식 있음: 양쪽

3.2 Enhanced Data Rate

3.2.1 Transmitter performance

RF Characteristics VCC = 3.3V, 25°C RF Characteristics VCC = 3.3V, 20°C			Min	Typ	Max	Bluetooth Specification	Unit
Maximum RF Transmit Power			-3	1	-	-6 to +4	dB
Relative Transmit Power			-4	-	1	-4 to +1	dB
Carrier Frequency Stability	π/4 DQPSK	ω <sub>0</sub>	-10	-	10	≤ ±10 for all blocks	kHz
		ω <sub>i</sub>	-75	-	75	≤ ±75 for all packets	kHz
		ω <sub>0</sub> + ω <sub>i</sub>	-75	-	75	≤ ±75 for all blocks	kHz
	8DPSK	ω <sub>0</sub>	-10	-	10	≤ ±10 for all blocks	kHz
		ω <sub>i</sub>	-75	-	75	≤ ±75 for all packets	kHz
		ω <sub>0</sub> + ω <sub>i</sub>	-75	-	75	≤ ±75 for all blocks	kHz
Modulation Accuracy	π/4 DQPSK	RMS DEVM	-	-	20	≤ 20	%
		99% DEVM	-	-	30	≤ 30	%
		Peak DEVM	-	-	35	≤ 35	%
	8DPSK	RMS DEVM	-	-	13	≤ 13	%
		99% DEVM	-	-	20	≤ 20	%
		Peak DEVM	-	-	25	≤ 25	%
EDR Differential Phase Encoding			99	-	-	≥ 99	%
In-band Spurious Emissions (8DPSK)	F ≥ F <sub>0</sub> + 3MHz		-	-	-40	≥ -40	dBm
	F < F <sub>0</sub> + 3MHz		-	-	-40	≥ -40	dBm
	F = F <sub>0</sub> - 3MHz		-	-	-40	≥ -40	dBm
	F = F <sub>0</sub> - 2MHz		-	-	-20	≥ -20	dBm
	F = F <sub>0</sub> - 1MHz		-	-	-26	≥ -26	dB
	F = F <sub>0</sub> + 1MHz		-	-	-26	≥ -26	dB
	F = F <sub>0</sub> + 2MHz		-	-	-20	≥ -20	dBm
	F = F <sub>0</sub> + 3MHz		-	-	-40	≥ -40	dBm

- 서식 있음: 제목 2
- 서식 있음: 글꼴: 10 pt, 밑줄 없음, 글꼴 색: 자동
- 서식 있음: 제목 3, 들여쓰기: 왼쪽: 0 cm, 내어쓰기: 3.93 글자
- 서식 있음: 글꼴: 10 pt

3.2.2 Receiver performance

RF Characteristics VCC = 3.3V, 25°C RF Characteristics VCC = 3.3V, 25°C			Min	Typ	Max	Bluetooth Specification	Unit
Sensitivity	π/4 DQPSK	-	-84	-70	≤ -70	dBm	

- 서식 있음: 글꼴: 10 pt, 밑줄 없음, 글꼴 색: 자동
- 서식 있음: 글꼴: 10 pt
- 서식 있음: 제목 3, 들여쓰기: 왼쪽: 0 cm, 내어쓰기: 3.93 글자
- 서식 있음: 글꼴: (영어) 바탕, (한글) 바탕, 10 pt, 굵게 없음, (Intl) Times New Roman
- 서식 있음: 양쪽

at 0.01% BER		8DPSK	-	-78	-70	$\leq -70$	dBm
BER floor performance			-	-	-60	$\leq -60$	dBm
C/I Performance (co-channel at 0.1% BER)		$\pi/4$ DQPSK	-	-	13	$\leq +13$	dB
		8DPSK	-	-	21	$\leq +21$	dB
C/I Performance (Adjacent Channel Selectivity)	$F = F_0 + 1\text{MHz}$	$\pi/4$ DQPSK	-	-	0	$\leq 0$	dB
		8DPSK	-	-	5	$\leq +5$	dB
	$F = F_0 - 1\text{MHz}$	$\pi/4$ DQPSK	-	-	0	$\leq 0$	dB
		8DPSK	-	-	5	$\leq +5$	dB
	$F = F_0 + 2\text{MHz}$	$\pi/4$ DQPSK	-	-	-30	$\leq -30$	dB
		8DPSK	-	-	-25	$\leq -25$	dB
	$F = F_0 - 2\text{MHz}$	$\pi/4$ DQPSK	-	-	-20	$\leq -20$	dB
		8DPSK	-	-	-13	$\leq -13$	dB
	$F \geq F_0 + 3\text{MHz}$	$\pi/4$ DQPSK	-	-	-40	$\leq -40$	dB
		8DPSK	-	-	-33	$\leq -33$	dB
	$F \leq F_0 - 5\text{MHz}$	$\pi/4$ DQPSK	-	-	-40	$\leq -40$	dB
		8DPSK	-	-	-33	$\leq -33$	dB
	$F = F_{\text{image}}$	$\pi/4$ DQPSK	-	-	-7	$\leq -7$	dB
		8DPSK	-	-	0	$\leq 0$	dB
Maximum input level at 0.1% BER		$\pi/4$ DQPSK	-20	-	-	$\geq -20$	dBm
		8DPSK	-20	-	-	$\geq -20$	dBm

4. Device Terminal Descriptions

서식 있음: 제목 1

서식 있음: 양쪽

### 4.1 UART Interface

This is a standard UART interface(TTL-Level) for communicating with other serial devices.

BCD210 UART interface provides a simple mechanism for communicating with other serial device using the RS232 protocol.

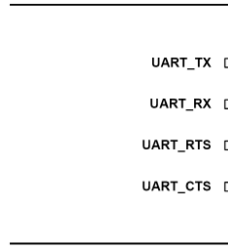

When BCD210 is connected to another digital device, UART\_RX and UART\_TX transfer data between the two devices. The remaining two signals, UART\_CTS, UART\_RTS, can be used to implement RS232 hardware flow control where both are active low indicators. All UART connections are implemented using CMOS technology and have signaling levels of 0V and 3.3V

Parameter		Possible Values
Baud Rate	Minimum	1200 baud (2%Error)
	Maximum	4M baud (1%Error)
Flow Control		RTS/CTS or None
Parity		None, Odd or Even
Number of Stop Bits		1 or 2
Bits per Channel		8

[Possible UART Settings]

서식 있음: 글꼴: 굵게, 밑줄 없음, 글꼴 색: 자동

서식 있음: 제목 2

서식 있음: 글꼴: (영어) 바탕, (한글) 바탕, 10 pt, (Intl) Times New Roman

서식 있음: 양쪽

## 4.2 USB Interface

서식 있음: 제목 2

BCD210 USB devices contain a full speed (12Mbps/s) USB interface that is capable of driving of a USB cable directly. No external USB transceiver is required. The device operates as a USB peripheral, responding to requests from a master host controller such as a PC. Both the OHCI and the UHCI standards are supported. The set of USB endpoints implemented behave as specified in the USB section of the Bluetooth specification v2.0+EDR or alternatively can appear as a set of endpoints appropriate to USB audio devices such as speakers.

As USB is a Master/Slave oriented system (in common with other USB peripherals), BCD210 only supports USB slave operation.

The USB data lines emerge as pins USB\_DP and USB\_DN. These terminals are connected to the internal USB I/O buffers of the BCD210, therefore, have low output impedance. To match the connection to the characteristic of the USB cable, resistors must be placed in series with USB\_DP/USB\_DN and the cable. BCD210 features an internal USB pull-up resistor. This pulls the USB\_DP pin weakly high when BCD210 is ready to enumerate. It signals to the PC that it is a full speed (12Mbit/s) USB device.

The USB internal pull-up is implemented as a current source, and is compliant with section 7.1.5 of the USB specification v1.2. The internal pull-up pulls USB\_DP high to at least 2.8V when loaded with a 15KΩ±5% pull-down resistor (in the hub/host) when VDD\_PADS=3.1V. This presents a Thevenin resistance to the host of at least 900Ω. Alternatively, an external 1.5KΩ pull-up resistor can be placed between a PIO line and D+ on the USB cable. The firmware must be alerted to which mode is used by PS key PSKEY\_USB\_PIO\_PULLUP appropriately. The default setting uses the internal pull-up resistor.

## 4.3 I<sup>2</sup>C Interface

서식 있음: 제목 2

PIO[8:6] can be used to form a mater I<sup>2</sup>C interface. The interface is formed using software to drive these lines. Therefore, it is suited only to relatively slow functions such as driving a dot matrix LCD (*Liquid Crystal Display*), keyboard scanner or EEPROM.

### Notes:

PIO lines need to be pull-up through 2.2KΩ resistors.

PIO[7:6] dual functions, UART bypass and EEPROM support, therefore, devices using an EEPROM cannot support UART bypass mode.

For connection to EEPROMs, refer to CSR documentation on I<sup>2</sup>C EEPROM for use with BlueCore. This provides information on the type of devices currently supported.

서식 있음: 양쪽

#### 4.4 PCM CODEC Interface

서식 있음: 제목 2

PCM (*Pulse Code Modulation*) is a standard method used to digitize audio (particularly voice) for transmission over digital communication channels. Through its PCM interface, BCD210 has hardware support for continual transmission and reception of PCM data, thus reducing processor overhead for wireless headset applications. BCD210 offers a bi-directional digital audio interface that route directly into the baseband layer of the on-chip firmware. It does not pass through the HCI protocol layer.

Hardware on BCD210 allows the data to be sent to and received from a SCO connection.

Up to three SCO connections can be supported by the PCM interface at any on time.

BCD210 can operate as PCM interface Master generating an output clock of 128, 256, or 512kHz. When configured as PCM interface slave, it can operate with an input clock up to 2048kHz. BCD210 is compatible with a variety of clock formats, including Long Frame Sync, Short Frame Sync and GCI timing environments.

It supports 13-bit or 16-bit liner, 8-bit u-law or A-law companied sample formats at 8k samples/s and can receive and transmit on any selection of three of the first four slots following PCM\_SYNC. The PCM configuration options are enabled by setting the PS Key PSKEY\_PCM\_CONFIG32 (0x1b3).

BCD210 interfaces directly to PCM audio devices including the following:

- Qualcomm MSM 3000 series and MSM 5000 series CDMA baseband devices
- OKI MSM7705 four channel A-law and u-law CODEC
- Motorola MC145481 8-bit A-law and u-law CODEC
- Motorola MC145483 13-bit linear CODEC
- STW 5093 and 5094 14-bit linear CODECs
- BCD210 is also compatible with the Motorola SSI™ interface

#### 4.5 I/O Parallel Ports

서식 있음: 제목 2

PIO lines can be configured through software to have either weak or strong pull-downs. All PIO lines are configured as inputs with weak pull-downs at reset.

Any of the PIO lines can be configured as interrupt request lines or as wake-up lines from sleep modes. PIO\_6 or PIO\_2 can be configured as a request line for an external clock source. This is useful when the clock to BCD210 is provided from a system ASIC (*Application Specific Integrated Circuit*). Using PSKEY\_CLOCK\_REQUEST\_ENABLE (0x246), this terminal can be configured to be low when BCD210 is in Deep Sleep and high when a clock is required. The clock must be supplied within 4ms of the rising edge of PIO\_6 or PIO\_2 to avoid losing timing accuracy in certain Bluetooth operating modes.

서식 있음: 양쪽

BCD210 has three general purpose analogue interface pins, AIO\_0, AIO\_1 and AIO\_2. These are used to access internal circuitry and control signals. One pin is allocated to decoupling for the on-chip band gap reference voltage, the other two may be configured to provide additional functionality.

### 4.6 Reset Interface

서식 있음: 제목 2

BCD210 may be reset from several sources: RESETB pin, power on reset, a UART break character or via a software configured watchdog timer.

The RESETB pin is an active low reset and is internally filtered using the internal low frequency clock oscillator.

A reset will be performed between 1.5 and 4.0ms following RESETB being active. It is recommended that RESETB be applied for a period greater than 5ms.

The power on reset occurs when the VDD\_CORE supply falls below typically 1.5V and is released when VDD\_CORE rises above typically 1.6V.

At reset the digital I/O pins are set to inputs for bi-directional pins and outputs are tri-state. The PIOs have weak pull-downs.

### 5. Application Schematic

서식 있음: 제목 1

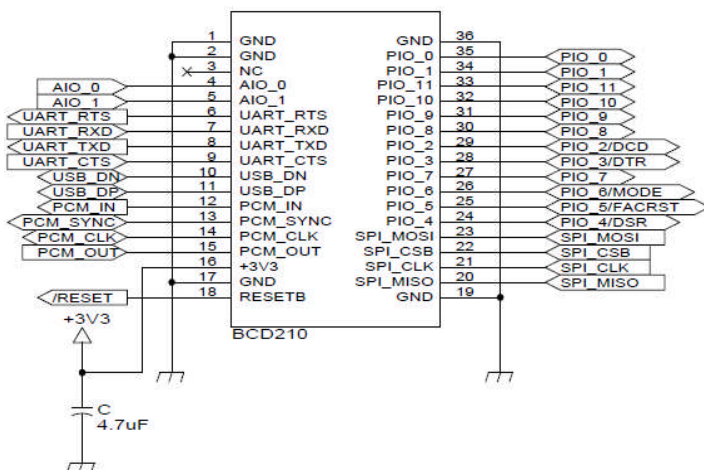

서식 있음: 양쪽

[BT Module Interface]

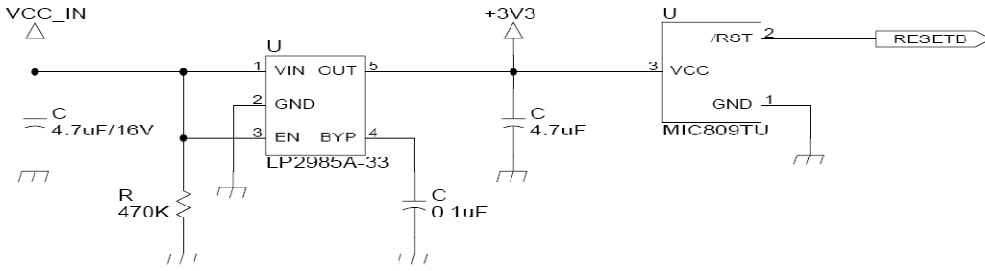

[Power Supply Interface]

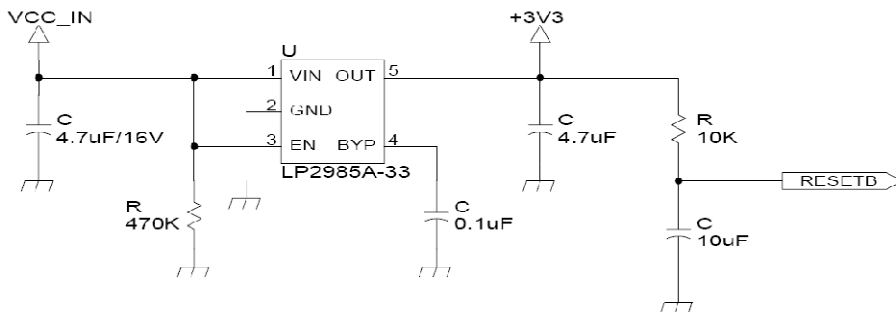

[Reset Interface]

서식 있음: 양쪽



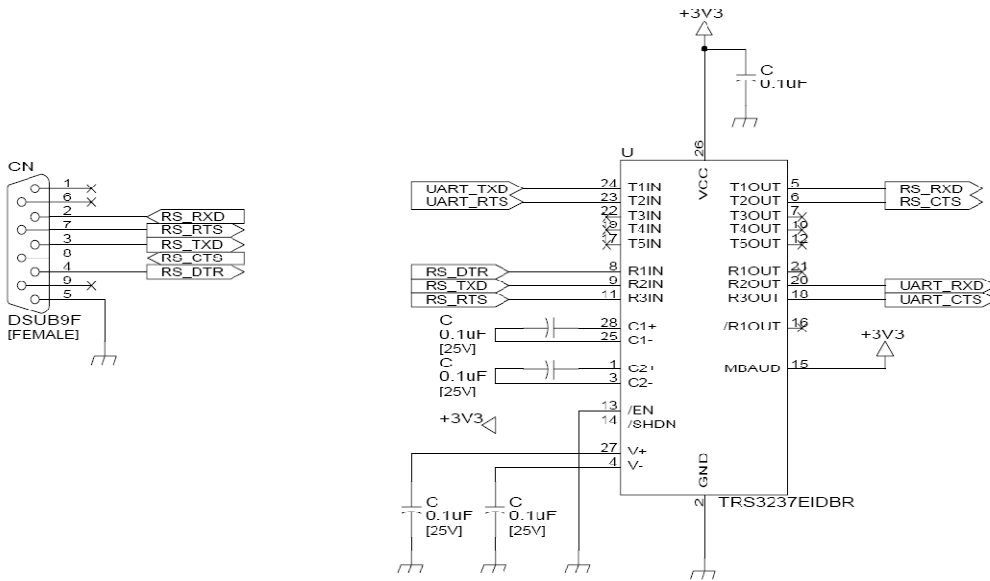

[Serial Interface for Host PC]

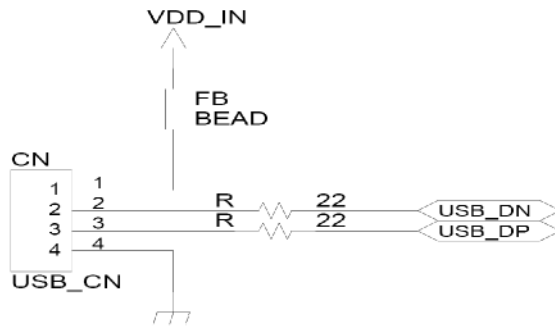

[USB Interface]

서식 있음: 양쪽



[ When TTL level of MICOM is 3.3V ]

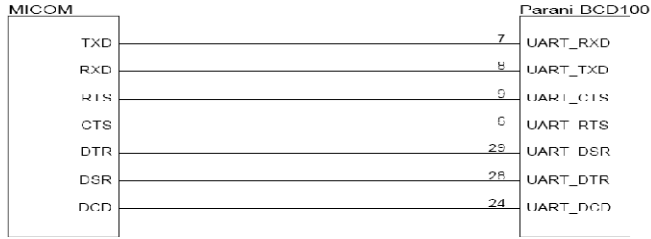

[ When TTL level of MICOM is 5.0V ]

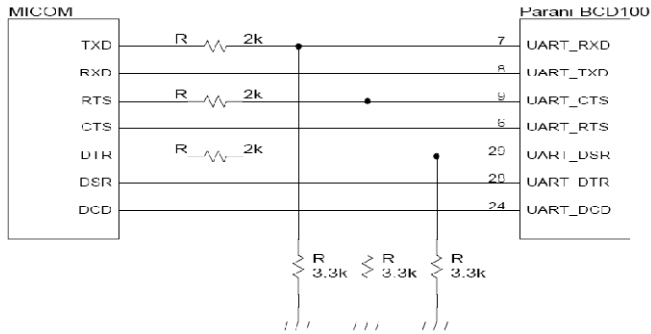

[MICOM UART Interface]

서식 있음: 양쪽

## 6. Software Stack

서식 있음: 제목 1

BCD400BCD210 is provided with Bluetooth v2.0 compatible firmware runs internally for SPP (Serial Port Profile) applications by default. The firmware is designed to work out-of-box for real world SPP applications such as POS (Point-of-sales), industrial automation, remote metering and other various applications.

The SPP firmware can be configured and controlled by typical AT commands. Users can easily configure BCD400BCD210 by using a terminal program such as HyperTerminal and can use Bluetooth wireless communication without modifying user's existing serial communication program. In addition to the basic AT commands, BCD400BCD210 provides some expanded AT commands for various functions. User friendly ParaniWizard and ParaniWIN are also provided for easy setup on Microsoft Windows. To run AT commands on the BCD400BCD210, the BCD400BCD210 should be connected to the serial port of the user's own board or equivalent to carry the BCD400BCD210.

The SPP firmware provided with the BCD400BCD210 is identical to the firmware of the Parani-ESD100V2 and Parani-ESD110V2. To shorten the overall development cycle or for quick verification during or before own development work, users might want to try ESD100V2/110V2 starter kits first for convenience. Also, please refer to the ESD100V2/110V2 user's manual for overall concept, configuration and complete AT commands list of the SPP firmware. The ESD100V2/110V2 user's manual can be downloaded from Sena support home page at <http://www.sena.com/support/downloads/>.

Optionally, the BCD400BCD210 can be supplied with only software stack up to HCI level so users can develop and embed their own firmware version into the BCD400BCD210 or entire Bluetooth stack runs on the host side for the application such as USB dongle for computers. Regarding these custom firmware options, please contact a Sena representative for more detail.

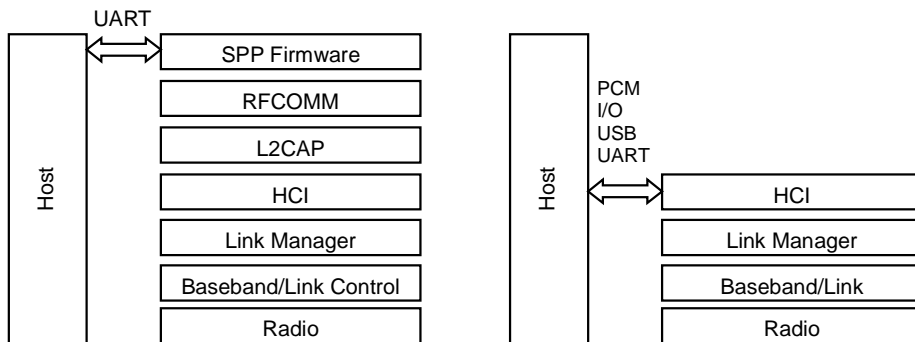

서식 있음: 양쪽

Figure 6-1 SPP Firmware Bluetooth software stack    Figure 6-2 HCI firmware Bluetooth Software Stack

## 7. Solder Profiles

The soldering profile depends on various parameters necessitating a set up for each application. The data here is given only for guidance on solder re-flow. There are four zones:

- **Preheat Zone** – This zone raises the temperature at a controlled rate, typically 1-2.5°C/s
- **Equilibrium Zone** – This zone brings the board to a uniform temperature and also activates the flux. The duration in this zone (typically 2-3 minutes) will need to be adjusted to optimize the out gassing of the flux.
- **Reflow Zone** – The peak temperature should be high enough to achieve good wetting but not so high as to cause component discoloration or damage. Excessive soldering time can lead to intermetal growth which can result in a brittle joint.
- **Cooling Zone** – The cooling rate should be fast, to keep the solder grains small which will give a longer lasting joint. Typical rates will be 2-5°C/s

서식 있음: 제목 1

서식 있음: 양쪽

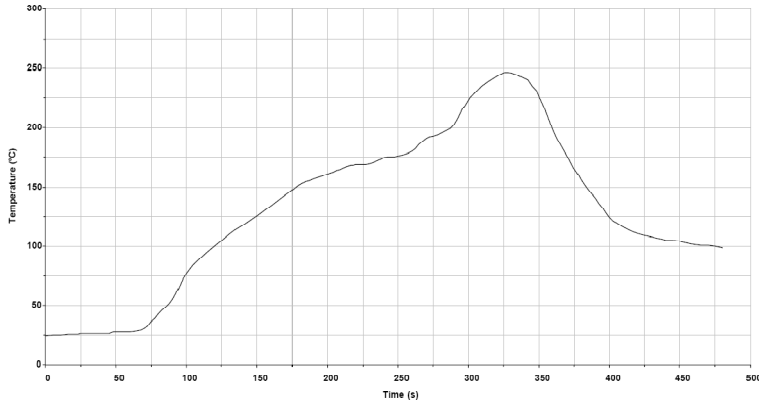

[Typical Lead-Free Re-flow Solder Profile]

**Key features of the profile:**

- Initial Ramp = 1-2.5°C/sec to 175°C±25°C equilibrium
- Equilibrium time = 60 to 180 seconds
- Ramp to Maximum temperature (245°C) = 3°C/sec max.
- Time above liquids temperature (217°C): 45~90 seconds
- Device absolute maximum reflow temperature: 260°C

Devices will withstand the specified profile.

Lead-free devices will withstand up to three reflows to a maximum temperature of 260°C

**8. Packaging Information**

서식 있음: 제목 1

서식 있음: 양쪽

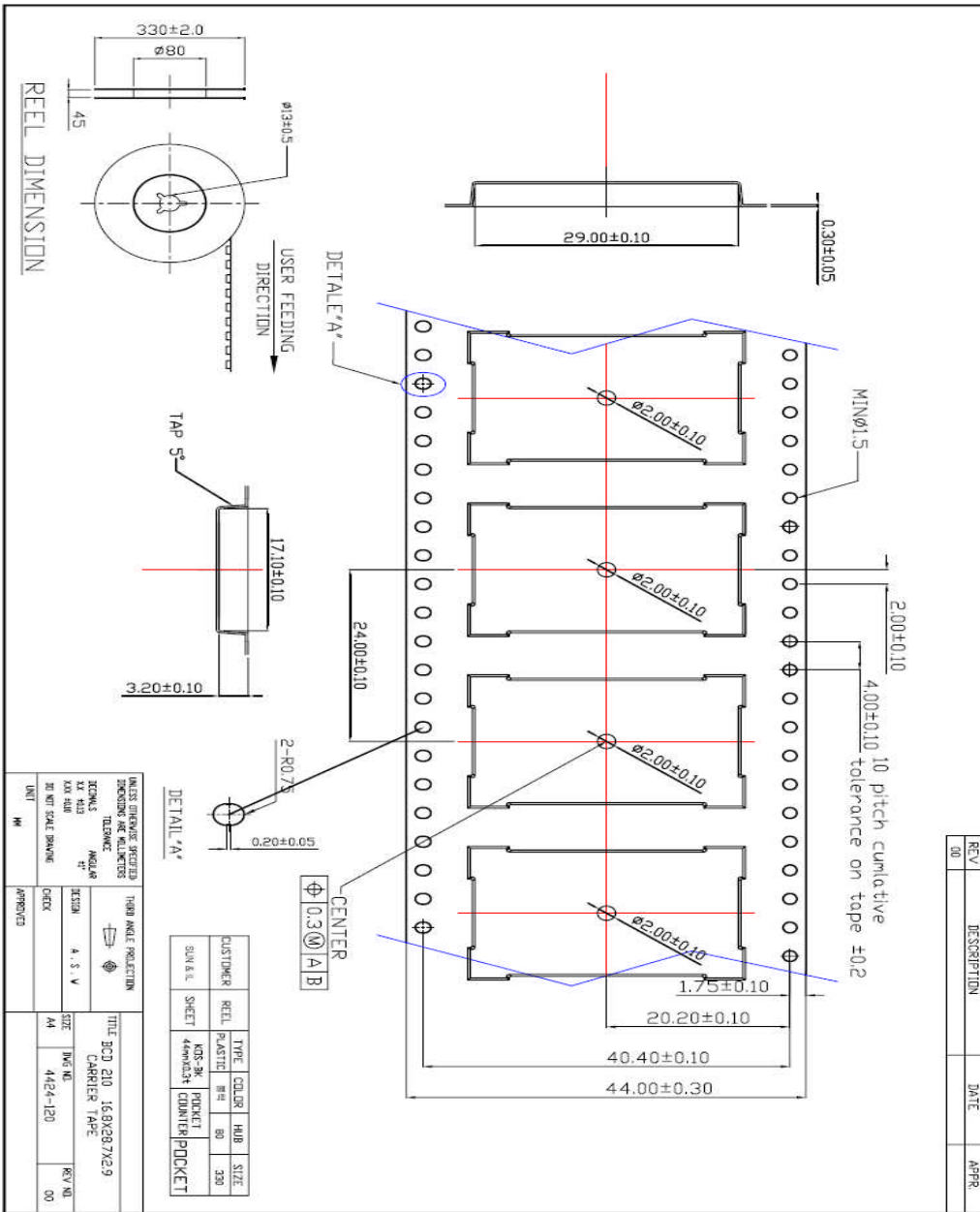

서식 있음: 양쪽

9. Certificate Information

9.1 FCC

FCC Rule: Part 15 Subpart C Section 15.247
FCCID: S7AIW03

9.1.1 FCC Compliance Statement

This device complies with part 15 of the FCC Rules. Operation is subject to the following two conditions:

- (1) This device may not cause harmful interference, and
(2) This device must accept any interference received,
Including interference that may cause undesired operation

Information to User

This equipment has been tested and found to comply with limits for a Class B digital device, Pursuant to Part 15 of the FCC Rules. These limits are designed to provide reasonable protection against harmful interference in a residential installation.

This equipment generate, uses and can radiate radio frequency energy and, if not installed and used in accordance with the instructions, may cause harmful interference to radio communications.

However, there is no guarantee that interference will not occur in a particular installation. If this equipment does cause harmful interference to radio or television reception, which can be determined by turning the equipment off and on, the user is encouraged to try to correct the interference by on or more of the following measures:

- Reorient or relocate the receiving antenna.
- Increase the separation between the equipment and receiver-Connect the equipment into an outlet a circuit different form that to which the receiver is connected.
- Consult the dealer or an experienced radio/TV technician for help.

9.1.2 RF Exposure Statement

The equipment complies with FCC RF radiation exposure limits set forth for an uncontrolled environment. This device and its antenna must not be co-located or operation in conjunction with any other antenna or transmitter.

9.1.3 Do not

Any changes or modifications to the equipment not expressly approved by the party responsible for compliance could void user's authority to operate the equipment.

서식 있음: 제목 1, 지정한 문자 수에 맞춰 오른쪽 들여쓰기 자동 조정

서식 있음: 제목 2, 지정한 문자 수에 맞춰 오른쪽 들여쓰기 자동 조정

서식 있음: 제목 3, 들여쓰기: 왼쪽: 0 cm, 내어쓰기: 4 글자, 지정한 문자 수에 맞춰 오른쪽 들여쓰기 자동 조정

서식 있음: 제목 3, 들여쓰기: 왼쪽: 0 cm, 내어쓰기: 4 글자, 지정한 문자 수에 맞춰 오른쪽 들여쓰기 자동 조정

서식 있음: 제목 3, 들여쓰기: 왼쪽: 0 cm, 내어쓰기: 1 글자, 첫 줄: -1 글자, 지정한 문자 수에 맞춰 오른쪽 들여쓰기 자동 조정

서식 있음: 양쪽



9.2 CE

Certification No: 1177

Declare under our own responsibility that the product

Bluetooth Module

Brand name: SENA

Model No.: Parani-BCD210DU / Parani-BCD210DC / Parani-BCD210DS

Parani-BCD210SU / Parani-BCD210SC

To which this declaration refers conforms with the relevant standards or other standardizing documents

EN 60950-1

ETSI EN 301 489-1

ETSI EN 301 489-17

ETSI EN 300 328

According to the regulations in Directive 1999/5/EC

서식 있음: 제목 2, 지정한 문자 수에 맞춰 오른쪽 들여쓰기 자동 조정

9.3 IC

Radio Cert. No.: IC: 8154A-IW03

서식 있음: 제목 2, 지정한 문자 수에 맞춰 오른쪽 들여쓰기 자동 조정

9.4 KC

Type Registration

Certification No: KCC-CRM-SNA-IW03

서식 있음: 제목 2, 지정한 문자 수에 맞춰 오른쪽 들여쓰기 자동 조정

9.5 TELEC

Technical Regulations for Specified Radio Equipment Article 2, Section 1 (19)

Certification No:

Parani-BCD210DU: 010WWBT0144

Parani-BCD210DC: 010WWBT0146

Parani-BCD210DS: 010WWBT0145

서식 있음: 제목 2, 지정한 문자 수에 맞춰 오른쪽 들여쓰기 자동 조정

9.6 SIG

QDID: B019536

Model Name: Parani-BCD210

Core Version: 2.0+EDR

Product Type: Component

Declared Specifications: Baseband Conformance, Radio, Service Discovery Protocol,

Logical Link Control and Adaption Protocol, Generic Access Profile, Link Manager, RFCOMM,

Serial Port Profile, Host Controller Interface, Summary ICS, Product Type

서식 있음: 제목 2, 지정한 문자 수에 맞춰 오른쪽 들여쓰기 자동 조정

서식 있음: 양쪽

서식 있음: 양쪽

**페이지 6: [1] 서식 있음** **kim** **2012-06-20 AM 8:27:00**

글꼴: (영어) Arial, (한글) 돋움, 굵게, 밑줄 없음, 글꼴 색: 자동

**페이지 6: [1] 서식 있음** **kim** **2012-06-20 AM 8:27:00**

글꼴: (영어) Arial, (한글) 돋움, 굵게, 밑줄 없음, 글꼴 색: 자동

**페이지 6: [2] 서식 있음** **kim** **2012-06-20 AM 9:08:00**

글꼴: 10 pt, 밑줄 없음, 글꼴 색: 자동

**페이지 6: [2] 서식 있음** **kim** **2012-06-20 AM 9:08:00**

글꼴: 10 pt, 밑줄 없음, 글꼴 색: 자동

**페이지 6: [3] 서식 있음** **kim** **2012-06-20 AM 9:08:00**

글꼴: 10 pt, 밑줄 없음, 글꼴 색: 자동

**페이지 6: [3] 서식 있음** **kim** **2012-06-20 AM 9:08:00**

글꼴: 10 pt, 밑줄 없음, 글꼴 색: 자동

**페이지 6: [4] 서식 있음** **kim** **2012-06-20 AM 9:08:00**

글꼴: (영어) Arial, 10 pt, 밑줄 없음, 글꼴 색: 자동

**페이지 6: [4] 서식 있음** **kim** **2012-06-20 AM 9:08:00**

글꼴: (영어) Arial, 10 pt, 밑줄 없음, 글꼴 색: 자동

**페이지 6: [5] 서식 있음** **kim** **2012-06-20 AM 9:08:00**

글꼴: (영어) Arial, 10 pt, 밑줄 없음, 글꼴 색: 자동

**페이지 6: [5] 서식 있음** **kim** **2012-06-20 AM 9:08:00**

글꼴: (영어) Arial, 10 pt, 밑줄 없음, 글꼴 색: 자동

**페이지 6: [5] 서식 있음** **kim** **2012-06-20 AM 9:08:00**

글꼴: (영어) Arial, 10 pt, 밑줄 없음, 글꼴 색: 자동

**페이지 6: [5] 서식 있음** **kim** **2012-06-20 AM 9:08:00**

글꼴: (영어) Arial, 10 pt, 밑줄 없음, 글꼴 색: 자동

**페이지 6: [6] 서식 있음** **kim** **2012-06-20 AM 9:08:00**

글꼴: (영어) Arial, 10 pt, 밑줄 없음, 글꼴 색: 자동

**페이지 6: [6] 서식 있음** **kim** **2012-06-20 AM 9:08:00**

글꼴: (영어) Arial, 10 pt, 밑줄 없음, 글꼴 색: 자동

**페이지 6: [6] 서식 있음** **kim** **2012-06-20 AM 9:08:00**

글꼴: (영어) Arial, 10 pt, 밑줄 없음, 글꼴 색: 자동

**페이지 6: [7] 서식 있음** **kim** **2012-06-20 AM 9:08:00**

글꼴: (영어) Arial, 10 pt, 밑줄 없음, 글꼴 색: 자동

**페이지 6: [7] 서식 있음** **kim** **2012-06-20 AM 9:08:00**

글꼴: (영어) Arial, 10 pt, 밑줄 없음, 글꼴 색: 자동

<b>페이지 6: [7] 서식 있음</b>	<b>kim</b>	<b>2012-06-20 AM 9:08:00</b>
글꼴: (영어) Arial, 10 pt, 밑줄 없음, 글꼴 색: 자동		
<b>페이지 6: [8] 서식 있음</b>	<b>kim</b>	<b>2012-06-20 AM 9:08:00</b>
글꼴: (영어) Arial, 10 pt, 밑줄 없음, 글꼴 색: 자동		
<b>페이지 6: [8] 서식 있음</b>	<b>kim</b>	<b>2012-06-20 AM 9:08:00</b>
글꼴: (영어) Arial, 10 pt, 밑줄 없음, 글꼴 색: 자동		
<b>페이지 6: [8] 서식 있음</b>	<b>kim</b>	<b>2012-06-20 AM 9:08:00</b>
글꼴: (영어) Arial, 10 pt, 밑줄 없음, 글꼴 색: 자동		
<b>페이지 6: [9] 서식 있음</b>	<b>kim</b>	<b>2012-06-20 AM 9:08:00</b>
글꼴: 10 pt, 밑줄 없음, 글꼴 색: 자동		
<b>페이지 6: [9] 서식 있음</b>	<b>kim</b>	<b>2012-06-20 AM 9:08:00</b>
글꼴: 10 pt, 밑줄 없음, 글꼴 색: 자동		
<b>페이지 6: [10] 서식 있음</b>	<b>kim</b>	<b>2012-06-20 AM 9:08:00</b>
글꼴: (영어) Arial, 10 pt, 밑줄 없음, 글꼴 색: 자동		
<b>페이지 6: [10] 서식 있음</b>	<b>kim</b>	<b>2012-06-20 AM 9:08:00</b>
글꼴: (영어) Arial, 10 pt, 밑줄 없음, 글꼴 색: 자동		
<b>페이지 6: [10] 서식 있음</b>	<b>kim</b>	<b>2012-06-20 AM 9:08:00</b>
글꼴: (영어) Arial, 10 pt, 밑줄 없음, 글꼴 색: 자동		
<b>페이지 6: [11] 서식 있음</b>	<b>kim</b>	<b>2012-06-20 AM 9:08:00</b>
글꼴: (영어) Arial, 10 pt, 밑줄 없음, 글꼴 색: 자동		
<b>페이지 6: [11] 서식 있음</b>	<b>kim</b>	<b>2012-06-20 AM 9:08:00</b>
글꼴: (영어) Arial, 10 pt, 밑줄 없음, 글꼴 색: 자동		
<b>페이지 6: [11] 서식 있음</b>	<b>kim</b>	<b>2012-06-20 AM 9:08:00</b>
글꼴: (영어) Arial, 10 pt, 밑줄 없음, 글꼴 색: 자동		
<b>페이지 6: [12] 서식 있음</b>	<b>kim</b>	<b>2012-06-20 AM 9:08:00</b>
글꼴: (영어) Arial, 10 pt, 밑줄 없음, 글꼴 색: 자동		
<b>페이지 6: [12] 서식 있음</b>	<b>kim</b>	<b>2012-06-20 AM 9:08:00</b>
글꼴: (영어) Arial, 10 pt, 밑줄 없음, 글꼴 색: 자동		
<b>페이지 6: [12] 서식 있음</b>	<b>kim</b>	<b>2012-06-20 AM 9:08:00</b>
글꼴: (영어) Arial, 10 pt, 밑줄 없음, 글꼴 색: 자동		
<b>페이지 6: [13] 서식 있음</b>	<b>kim</b>	<b>2012-06-20 AM 9:08:00</b>
글꼴: (영어) Arial, 10 pt, 밑줄 없음, 글꼴 색: 자동		
<b>페이지 6: [13] 서식 있음</b>	<b>kim</b>	<b>2012-06-20 AM 9:08:00</b>
글꼴: (영어) Arial, 10 pt, 밑줄 없음, 글꼴 색: 자동		

<b>페이지 6: [13] 서식 있음</b>	<b>kim</b>	<b>2012-06-20 AM 9:08:00</b>
글꼴: (영어) Arial, 10 pt, 밑줄 없음, 글꼴 색: 자동		
<b>페이지 6: [14] 서식 있음</b>	<b>kim</b>	<b>2012-06-20 AM 9:08:00</b>
글꼴: (영어) Arial, 10 pt, 밑줄 없음, 글꼴 색: 자동		
<b>페이지 6: [14] 서식 있음</b>	<b>kim</b>	<b>2012-06-20 AM 9:08:00</b>
글꼴: (영어) Arial, 10 pt, 밑줄 없음, 글꼴 색: 자동		
<b>페이지 6: [14] 서식 있음</b>	<b>kim</b>	<b>2012-06-20 AM 9:08:00</b>
글꼴: (영어) Arial, 10 pt, 밑줄 없음, 글꼴 색: 자동		
<b>페이지 6: [15] 서식 있음</b>	<b>kim</b>	<b>2012-06-20 AM 9:08:00</b>
글꼴: (영어) Arial, 10 pt, 밑줄 없음, 글꼴 색: 자동		
<b>페이지 6: [15] 서식 있음</b>	<b>kim</b>	<b>2012-06-20 AM 9:08:00</b>
글꼴: (영어) Arial, 10 pt, 밑줄 없음, 글꼴 색: 자동		
<b>페이지 6: [15] 서식 있음</b>	<b>kim</b>	<b>2012-06-20 AM 9:08:00</b>
글꼴: (영어) Arial, 10 pt, 밑줄 없음, 글꼴 색: 자동		
<b>페이지 6: [16] 서식 있음</b>	<b>kim</b>	<b>2012-06-20 AM 9:08:00</b>
글꼴: (영어) Arial, 10 pt, 밑줄 없음, 글꼴 색: 자동		
<b>페이지 6: [16] 서식 있음</b>	<b>kim</b>	<b>2012-06-20 AM 9:08:00</b>
글꼴: (영어) Arial, 10 pt, 밑줄 없음, 글꼴 색: 자동		
<b>페이지 6: [16] 서식 있음</b>	<b>kim</b>	<b>2012-06-20 AM 9:08:00</b>
글꼴: (영어) Arial, 10 pt, 밑줄 없음, 글꼴 색: 자동		