



Connectware™



Digi Connect User's Guide



Making
DEVICE NETWORKING
easy™

© Digi International Inc. 2003. All Rights Reserved

The Digi logo and RealPort are registered trademarks of Digi International, Inc.

Connectware and Digi Connect ME are trademarks of Digi International, Inc.

Adobe and Adobe Acrobat are registered trademarks of Adobe Systems, Inc.

Microsoft and Windows are registered trademarks of Microsoft Corporation.

Information in this document is subject to change without notice and does not represent a commitment on the part of Digi International.

Digi provides this document “as is,” without warranty of any kind, either expressed or implied, including, but not limited to, the implied warranties of fitness or merchantability for a particular purpose. Digi may make improvements and/or changes in this manual or in the product(s) and/or the program(s) described in this manual at any time.

This product could include technical inaccuracies or typographical errors. Changes are periodically made to the information herein; these changes may be incorporated in new editions of the publication.

Contents

About This Guide

Objective	7
Audience	7
Related Information.....	7

Chapter 1 Quick Start Setup

Introduction	9
Quick Start Overview	9
Quick Start Procedure.....	9

Chapter 2 Configuring Network Settings

Introduction	13
Configuring Network Settings	13

Chapter 3 Configuring Network Communications

Introduction	15
Setting Up RealPort COM Port Redirection	16
Configuring a TCP or UDP Server	18
Configuring a TCP Client	20
Configuring a UDP Client	22

Chapter 4 Configuring GPIO Pins and Alarms

Introduction	25
Configuring the GPIO Pins.....	26
Configuring Alarms	27

Chapter 5 Testing GPIO Functionality

Introduction	29
Getting Familiar with GPIO Input	29
Getting Familiar with GPIO Output	30

Chapter 6 Administration

Introduction	31
Restoring the Configuration to Factory Defaults	31
Backing Up the Configuration	31
Restoring the Configuration	32
Viewing System Information	32
Viewing Serial and GPIO Port Statistics	33
Rebooting the Module.....	33

Index	35
--------------------	-----------

About This Guide

Objective

This manual shows you how to configure and administer the Digi Connect product family. Once configured, you can access the web interface and become familiar with the capabilities.

Audience

This manual is intended for those responsible for setting up a Digi Connect product. It assumes that the reader is somewhat familiar with networking.

Related Information

In addition to this manual, the following documents are part of the Digi Connect library:

- *Digi Connect platform Hardware Reference*
- *Digi Connect Customization Guide*

Introduction

This chapter describes how to set up the Digi Connect product and install the customization kit.

Quick Start Overview

1. Physically connect the hardware.
2. Install the software and tools.
3. Locate the product on the network and configure network settings.
4. Access the product from a web browser.
5. Get familiar with the product and customization kit features.

Quick Start Procedure

1. Connect the Ethernet cable to the product.
2. Connect the power to the Digi Connect product.

The following figure shows a hardware set up for Connect ME.

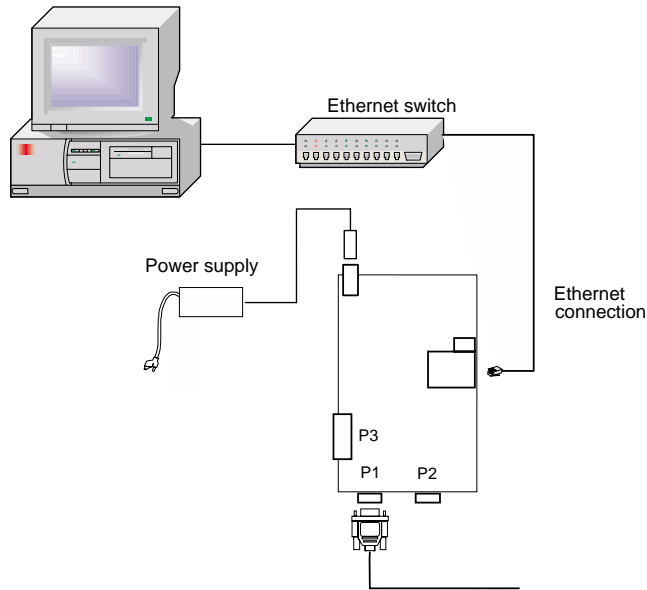

Task 2: Install the Software and Tools

3. Place the customization kit CD in the CD drive.

The installation wizard appears.

4. Choose Next to start the installation process.
5. Choose I Agree to the license agreement prompt and then click Next.
6. Choose an installation type.
 - Typical means that sample applications, documentation, and RealPort will be installed and third-party applications will not be installed. These include the following:
 - Adobe Acrobat Reader. Install this application if you want to view online documentation and the Reader is not already on your system.
 - Microsoft Internet Explorer (IE) 6. Install IE 6 if your

current browser does not support the Java plug-in, which is required to view the Java-based configuration application.

— Sun Java Run-time Environment (JRE) 1.4.1.
Install the JRE if you need the Java plug-in.

- Advanced means that you pick components to install.

7. Follow the prompts to complete installation.

Task 3: Locate the Digi Connect product and Configure Network Settings

8. From the Windows Start Menu, choose Programs > Digi Connect > Digi Device Discovery.

Device Discovery locates and lists Digi products on the network.

9. Select your product from the list and do one of the following:

- If a DHCP server assigned an IP address to your product, go to the next step.
- If your product requires an IP address, choose Configure Network Settings and assign network settings.

Task 4: Access the Product from a Web Browser

10. Select the product and then choose Open Web Interface.

A browser connection is opened to the module.

Note: If you did not install the JRE and do not have it on your system, it will be downloaded from the internet prior to the configuration application opening. This can take several minutes.

11. Use the browser interface to configure the product and get familiar with its features.

Chapter 3 Configuring Network Settings

Introduction

This chapter describes how to change network settings. It assumes that you have assigned initial network settings to the product as described in "Quick Start Setup" on page 9.

Configuring Network Settings

Introduction

This section provides information on changing network settings, such as the module's IP address, subnet mask, and default gateway.

Procedure

1. Access the web interface by entering the product's IP address in a browser's URL window.
2. Choose Network from the Configuration menu.
3. Choose the Basic tab.
4. Make changes as required and then choose Save. See your network administrator to gather the information required to ensure that the product is configured correctly for your network. See the table that follows for information on configuration fields.

Setting	Description
Obtain automatically using DHCP	Choose this option to assign network settings using a DHCP server. A new IP address will be assigned when the product reboots. Choose this setting only if you have a DHCP server.
Use the following IP address	Choose this option to configure the product with the IP address supplied in the IP Address field.
IP Address	Specify an IP address to assign the product.
Subnet Mask	Specify the subnet mask used on this network.
Default Gateway	Specify the IP address of the default gateway or router whose services the product will use to route messages to systems and devices on other networks.

Note: When you change the network configuration, a reboot is required, which means you will have to reconnect to the product with your browser.

Introduction

This chapter describes a number ways to set up the product to provide communication services to devices connected to its serial port; it also provides detailed setup information.

Setting Up RealPort COM Port Redirection

Introduction

This section discusses RealPort COM port redirection. It describes what RealPort is and provides detailed instruction for installing the RealPort driver on a Microsoft Windows system. It also provides information on downloading the latest RealPort driver from the Digi web site.

What is RealPort?

RealPort is a network communication option for applications designed to communicate with serial devices using COM ports. With RealPort, the application simply opens a RealPort virtual COM port that directs the data across the network to your device.

The advantage of this option is that neither the application nor the serial device need to be changed from their original serial communication model to work on a network. Both continue to use serial communication techniques, and neither is aware of the intervening network.

In the figure that follows, an application and your device with the embedded Digi Connect ME module communicate as though they were connected with a serial cable.

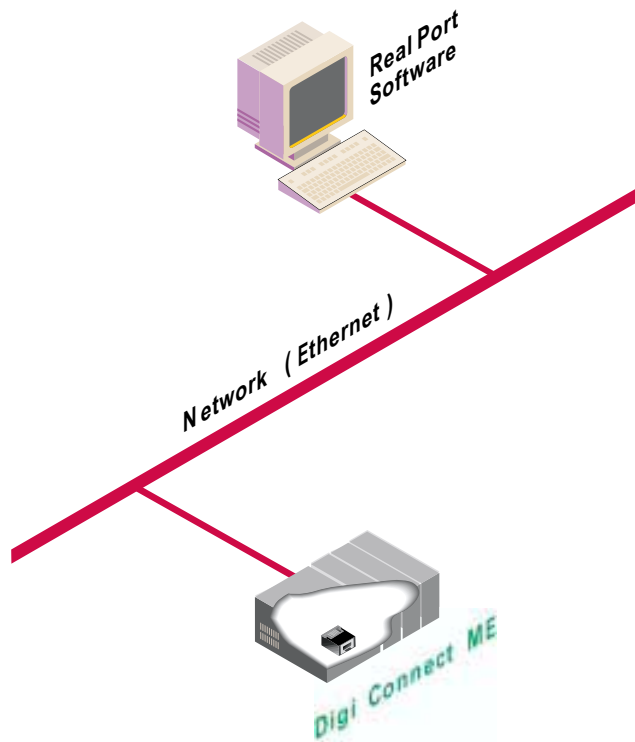

Procedure: Installing RealPort

Use this procedure to install RealPort software on the same computer that the Integration kit software and tools were installed.

1. From the Start Menu, choose Programs > Digi Connect > RealPort > InstallRealPortXxx, where Xxx is a version or versions of Microsoft Windows.
2. Follow the on-screen documentation to complete installation. When the installation completes, RealPort will be ready to use.

Procedure: Downloading and Installing RealPort

Use this procedure to download and install a RealPort driver from the Digi web site.

1. Go to www.digi.com
2. Locate the RealPort driver and follow the instructions for downloading it.
3. Use the readme.html file for installation instructions.
When the installation completes, RealPort will be ready to use.

Configuring a TCP or UDP Server

Introduction

This section describes how to set up the module as a TCP or UDP server. It describes the features of this configuration and provides information on configuring the product.

About This Configuration

This configuration provides TCP or UDP socket service for a device connected to the serial port. In this configuration, another networked device or application initiates communication. The product simply waits for incoming traffic and passes data to the serial device. The figure illustrates this configuration.

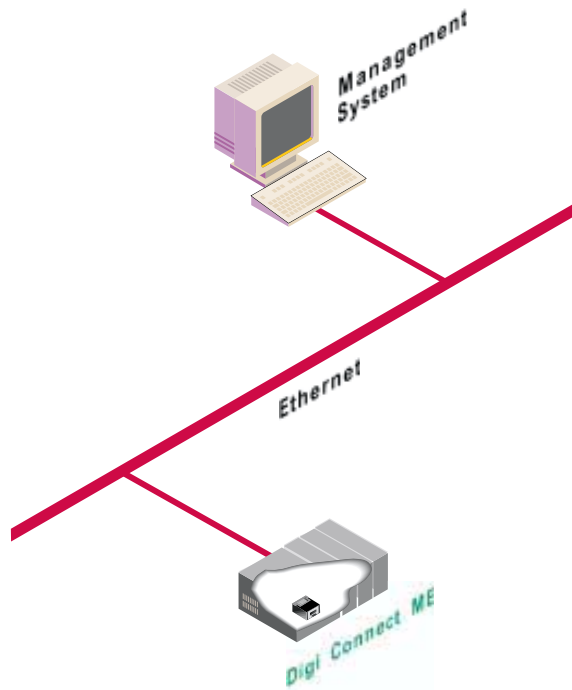

Procedure: Configuring Digi Connect as a TCP/UDP Server

1. Access the web interface by entering the product's IP address in a browser's URL window.
2. Choose Serial Ports from the Configuration menu.
3. Choose the Basic tab and then configure serial communication settings. When you complete this task, choose Save.
4. Choose either the TCP or UDP tab.
5. Check the Enable TCP Server or Enable UDP Server box and then configure a TCP or UDP port to which the product will pass incoming data. Use the port number required by your application.
6. Choose Save.

Configuring a TCP Client

Introduction

This section describes how to configure the product as a TCP client. It describes the features of this configuration and provides detailed setup procedures.

About This Configuration

In this configuration, the device initiates TCP connections to applications running on servers or to devices connected to server serial ports. This is sometimes called TCP socket service. The connection can be configured to be always active or to be triggered by a particular event, such as when the DCD signal goes high or data arrives at the port. The figure illustrates this configuration.

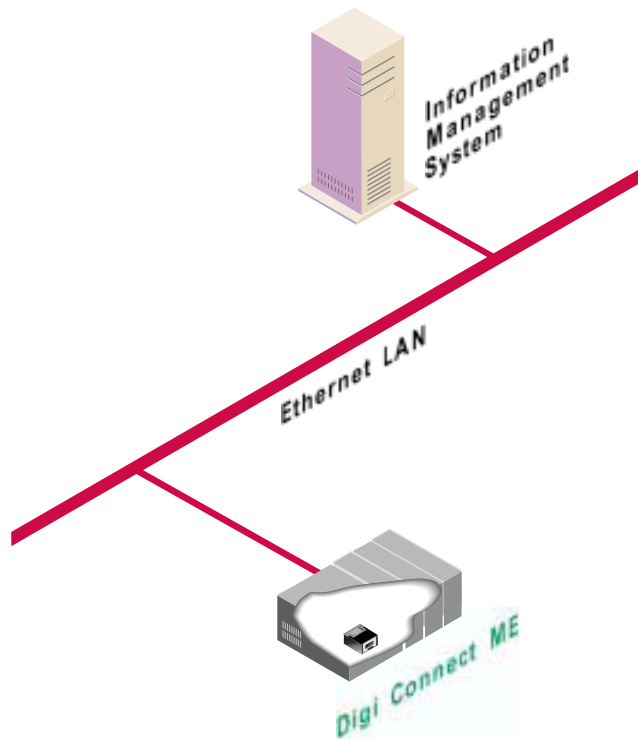

Procedure

1. Access the web interface by entering the product's IP address in a browser's URL window.
2. Choose Serial Ports from the Configuration menu.
3. Choose the Basic tab and configure serial communication settings. When you complete this task, choose Save.
4. Choose the TCP tab and then configure TCP Client settings. Use the following table for information on settings. When you are done choose Save.

Setting	Description
Automatically establish TCP connections	Check this field if you want the product to trigger automatic TCP connections to the server identified on the Connect To field. Connections will be triggered by the event specified in the Connect field.
Connect	Configure the event that will trigger a connection: <ul style="list-style-type: none">• Always means a connection is always available. If lost, the connection will be reestablished automatically.• Data means the product initiates a connection whenever data arrives on the serial port.• DSR means a connection is made when the serial port's DSR signal goes high.• DCD means a connection is made when the serial port's DCD signal goes high.
Connect to	Specify the IP address of the server to which a connection will be made.
Service	Configure the type of service to use.
TCP Port Number	Configure the TCP port number for this connection. Use the port number required by the application.

Configuring a UDP Client

Introduction

This section describes how to configure the product as a UDP client. It describes the features of the configuration and provides detailed configuration instructions.

About This Configuration

In this configuration, the device connected to the serial port initiates UDP communications to applications running on servers and serial devices connected to server serial ports. This is sometimes called UDP socket service and can be used to communicate with multiple devices simultaneously.

Procedure

1. Access the web interface by entering the product's IP address in a browser's URL window.
2. Choose Serial Ports from the Configuration menu.
3. Choose the Basic tab and configure serial communication settings. When you complete this task, choose Save.
4. Choose the UDP tab.
5. Check UDP Client Enabled and then configure UDP client settings. Use the following table for information on settings. When you are done, choose Save.

Setting	Description
IP Address	Specify the IP address of the device or system to which data will be sent.
UDP Port	Specify the destination UDP port.
Description	Supply a description of the destination, a text string to identify the destination.
Enabled	Check this field to activate this configuration entry.

Setting	Description
Send data when the following string is found	Check this field to trigger UDP communication when one of the following strings appear in the data stream: <ul style="list-style-type: none"> • CR (carriage return) • CR/LF (carriage return/linefeed) • Custom String, which can be a string of one to four characters. To use hexadecimal values use <code>\xhh</code>, where <code>hh</code> is replaced with a hexadecimal number.
Send data after the following number of idle milliseconds	Check this field if you want the product to send the buffer after waiting a specified period for additional data. Then specify the period to wait. The range is 1 to 65535 milliseconds, and the default is 100 milliseconds.
Send data after the following number of bytes	Check this field and then specify the maximum number of bytes the buffer can accumulate before forwarding the contents. The range is 1 to 65535 bytes, and the default is 1024 bytes

Introduction

This chapter describes how to configure GPIO pins and the email alarms that can be triggered when GPIO input signals are raised. It discusses the following topics:

- Configuring the GPIO Pins, which describes how to configure the GPIO pins for flow control or for a user-defined purpose
- Configuring Alarms, which describes how to configure the product so that email notifications are generated when certain events occur

Configuring the GPIO Pins

Introduction

The Digi Connect ME provides five General Purpose IO (GPIO) pins that can be used for either standard serial communication signalling (DTR, CTS, etc.) or for a user-defined purpose, such as when a significant event occurs within the device. In the latter case, the module can be configured so that when an event occurs, an email alarm is sent to an administrator or technician. The Digi Connect EM also provides GPIO pins.

Procedure

1. Access the web interface by entering the module's IP address in a browser's URL window.
2. Choose GPIO from the Configuration Menu.
3. Configure the pins as required. This involves two choices:
 - Whether to use a pin for standard serial communication signalling or for a user-defined purpose. The default setting is Serial, which means the port will be used for serial communication signalling. The following table maps GPIO pins to serial communication signals:

GPIO Pin	Signal
1	DCD
2	CTS
3	DSR
4	RTS
5	DTR

- Whether a user-defined pin is for output (from the module to the connected device) or input (from the device to the module). Email notification is possible only when a pin is configured for input.
4. When you complete configuration, choose Save.

5. If you want to trigger email alarms based on the state of a port, see the following discussion.

Configuring Alarms

Introduction

This section describes how to configure the module to send email alarms when a GPIO pin signals that an event has occurred on the device.

Procedure

1. Access the web interface by entering the module's IP address in a browser's URL window.
2. Choose Alarms from the Management menu.
3. Check Enable Sending Alarms.
4. Configure SMTP alarms settings and then click Save. Use the following table for information on configuration fields.

Setting	Description
SMTP server address	Is the email address of the email server
From user	Is the email address of this client
Enable alarm	Must be checked to activate this alarm
Trigger condition	Determines the GPIO pins and conditions that trigger an alarm. Here is how this works: <ul style="list-style-type: none">• The trigger can be any combination of pins.• An x means do <u>not</u> use this pin as part of the trigger mechanism.• A 1 means trigger the alarm on a raised signal.• A 0 means trigger the alarm on a lowered signal.
Trigger Interval	Is the period to wait in seconds before sending another email alarm when an alarm condition persists.
Trigger only on transition	Means trigger the alarm only when the signal on the pin goes from low to high or high to low.

Setting	Description
To user	Is the email address of an administrator or technician who will receive this email alarm.
Subject	Is a text message in the email header, which should describe or identify the alarm. This can be up to a maximum of 64 characters.
CC user	Is the address of another administrator or technician who will receive a copy of the email alarm.
Priority	Determines whether the email is labelled normal or high priority.

Introduction

This chapter describes how to use the development board switches and the web interface to learn about GPIO functionality on the Digi Connect ME or Digi Connect EM.

Getting Familiar with GPIO Input**Introduction**

This section familiarizes you with GPIO input to the module. Typically, you will use input signals on GPIO pins to trigger an email alarm, which tells an administrator or technician that a significant event has occurred within the device.

Procedure

1. On the SW2 bank of switches on the development board, ensure that one of the GPIO pins is set to high.
2. On the SW1 bank of switches, set the same GPIO pin to IO.
3. Configure the GPIO pin for input. See "Configuring the GPIO Pins" on page 26 for more information.
4. Configure an email alarm. See "Configuring Alarms" on page 27.
5. Toggle the SW2 switch several times to generate several email alarms.

Getting Familiar with GPIO Output

Introduction

This section familiarizes you with GPIO output from the module. In this procedure, raising a GPIO signal from the configuration application causes an LED on the development board to turn on.

Procedure

1. On the SW2 bank of switches on the development board, ensure that one of the GPIO pins is set to high.
1. Configure GPIO pins for output. See "Configuring the GPIO Pins" on page 26 for more information.
2. Choose System Information and then the GPIO tab.
3. Choose Assert to raise the signal and then click Set Pins.

An LED on the development board is turned on.

Note: This procedure does not configure the module. Settings are not saved. If the module reboots, you will have to do steps 2 and 3 again.

Introduction

This chapter describes how to perform various administrative functions, such as backing up and restoring the configuration and rebooting the module.

Restoring the Configuration to Factory Defaults**Introduction**

The procedure in this section shows you how to reset the configuration to Digi default.

Procedure

1. Access the web interface by entering the device's IP address in a browser's URL window.
2. Choose Restore Factory Defaults from the menu.
3. Click the Restore Now button.

Backing Up the Configuration**Introduction**

This section describes how to back up the configuration to a server.

Procedure

1. Access the web interface by entering the device's IP address in a browser's URL window.

2. Choose Backup/Restore.
3. Choose Backup.
4. Follow the prompts to complete the backup operation.

Restoring the Configuration

Introduction

This section describes how to restore a configuration that has been saved to a server.

Procedure

1. Access the web interface by entering the device's IP address in a browser's URL window.
2. Choose Backup/Restore.
3. Choose Restore.
4. Follow the prompts to restore the configuration.

Viewing System Information

Introduction

Use this procedure to view system information, such as the module's IP address and MAC address.

Procedure

1. Access the web interface by entering the device's IP address in a browser's URL window.
2. Choose Home from the menu.

Viewing Serial and GPIO Port Statistics

Introduction

Use this procedure to view serial and GPIO port statistics.

Procedure

1. Access the web interface by entering the device's IP address in a browser's URL window.
2. Choose System Information from the menu.
3. Use the tabs to move between views. Use the Refresh button to refresh statistics.

Rebooting the Module

Introduction

Use this procedure to reboot the module.

Procedure

1. Access the web interface by entering the device's IP address in a browser's URL window.
2. Choose Reboot from the menu.
3. Click the Reboot button.

C

- COM port redirection
 - defined 16
 - installing the RealPort driver 17
- configuration
 - backing up 31
 - resetting to defaults 31
 - restoring 32

D

- default configuration, resetting 31
- default gateway, configuring 13
- documentation, related 7

E

- email alarms, configuring 27

G

- gateway, configuring 13
- GPIO pins
 - configuring 26
 - statistics 33
- GPIO ports
 - statistics 33

I

- installing software 10
- IP address, configuring 13

M

- module discovery 11

N

- network settings 11
 - configuring basic settings 13
- notification, configuring 27

P

- port statistics 33

Q

- quick start setup 9

R

- RealPort
 - defined 16
 - driver installation 17
- rebooting 33
- related documentation 7

resetting the configuration to defaults 31

S

serial statistics 33

setup

 quick start 9

 software 10

software, installing 10

statistics

 GPIO 33

 port 33

subnet mask, configuring 13

system information, viewing 32

T

TCP

 client configuration 20

 server configuration 18

U

UDP

 client configuration 22

 server configuration 18



Connectware™

Digi International

11001 Bren Road East
Minnetonka, MN 55343
U.S.A

952-912-3444

www.digi.com



PN:(1P) 90000319 B