

IALink Series

IALink100-Modbus

User Guide

Version 1.0.0

2002-12-01

User Guide for the IALink100-Modbus

Version 1.0.0

Firmware version 1.0.*

Printed in Korea

Copyright

Copyright 2002, Sena Technologies, Inc. All rights reserved.

Sena Technologies reserves the right to make changes and improvements to its product without providing notice.

Trademark

IALink100-Modbus™ is a trademark of Sena Technologies, Inc.

Windows® is a registered trademark of Microsoft Corporation.

Ethernet® is a registered trademark of XEROX Corporation.

Notice to Users

When a system failure may cause serious consequences, protecting life and property against such consequences with a backup system or safety device is essential. The user agrees that protection against consequences resulting from system failure is the user's responsibility.

This device is not approved for life -support or medical systems.

Changes or modifications to this device not explicitly approved by Sena Technologies will void the user's authority to operate this device.

Technical Support

Sena Technologies, Inc.

210 Yangjae-dong, Seocho-gu

Seoul 137-130, Korea

Tel: (+82-2) 573-5422

Fax: (+82-2) 573-7710

E-Mail: support@sena.com

Website: <http://www.sena.com>

Contents

1: Introduction	5
1.1 Overview	5
1.2 Package Check List	6
1.3 Product Specification	7
1.4 Terminologies and acronyms	8
2: Getting Started	10
2.1 Panel Layout	10
2.2 DIN Rail Mounting	11
2.3 Connecting the Hardware	11
2.3.1 Connecting the power	11
2.3.2 Connecting to the network	12
2.3.3 Connecting to the device	13
2.4 Accessing Console Port	13
2.4.1 Using Serial console	14
2.4.2 Using Remote console	15
3: IP Address Configuration	17
3.1 Static IP	17
3.1.1 Overview	17
3.1.2 IP address	17
3.1.3 Subnet mask	18
3.1.4 Default gateway	18
3.2 DHCP	19
3.2.1 Overview	19
3.2.2 DHCP setting	20
4: Modbus Configuration	21
4.1 Serial communication type	21
4.2 Modbus/Serial mode	22
4.3 Baud rate	22
4.4 Data bits, Stop bits, Parity	23
4.5 RTU/ASCII frame timeout	24
4.6 Attached serial device type	24
4.7 Unit ID / IP address lookup table	25
5: System administration	27
5.1 Remote host access control	27

5.2 User name and password	28
5.3 Firmware upgrade	29
6. Case study	31
Appendix A: Connections	34
A.1 Ethernet Pin outs	34
A.2 Serial Ports Pin Outs	35
A.3 Ethernet Wiring Diagram	36
A.4 Serial Wiring Diagram	36
Appendix B: Well-known port numbers	38
Appendix C: Troubleshooting	39
C.1 Power/LED status troubleshooting	39
C.2 Serial console troubleshooting	39
C.3 Remote console troubleshooting	40
C.4 IP address troubleshooting	40
C.5 DHCP troubleshooting	40

1: Introduction

1.1 Overview

The IALink Series allows you to network-enable a variety of industrial serial devices that were not originally designed for networking. This capability brings the advantages of remote management and data accessibility to thousands of industrial serial devices over the network.

The IALink100-Modbus is a Modbus/serial protocol to Modbus/TCP protocol gateway. Using the IALink100-Modbus, the users can connect various industrial facilities such as PLC, DCS, DDC, RTU which just support Modbus serial protocol with network devices supporting Modbus/TCP protocols, which let users to access and monitor the facilities at the remote site.

The IALink100-Modbus supports variety of the serial communication types such as RS232, RS422 or RS485 allowing virtually any asynchronous serial Modbus device to be accessed over a network. As for the network connectivity, the IALink100-Modbus supports open network protocols such as TCP/IP and DHCP.

The IALink100-Modbus was designed to accommodate the unique requirements of the industrial automation applications. The IALink100-Modbus is using the power of +7.5 ~ 30 VDC which allows very common power source of +24 VDC for the industrial automation applications. Also, the IALink100-Modbus has a DIN-rail mounting adaptor on the back of the case, which is a most common installation method for industrial automation applications.

Parts of this manual assume the knowledge on concepts of the Internetworking protocols and serial communications. If you are not familiar with these concepts, please refer to the standards or the documentation on each subject.

1.2 Package Check List

- IALink100-Modbus external box
- Serial console cable
- A hardcopy of Quick Start Guide
- CD-ROM including the HelloDevice Manager and User Guide

1.3 Product Specification

Serial Interface	1-port RS232/422/485 10 pin terminal block interface
	Serial speeds 1200bps to 115Kbps
	Flow Control: None, Hardware RTS/CTS
	Signals: RS232 Rx, Tx, RTS, CTS, DTR, DSR, GND RS422 Rx+, Rx-, Tx+, Tx- RS485 Data+, Data-
Network Interfaces	10 Base-T Ethernet with RJ45 Ethernet connector
	Supports static and dynamic IP address
Protocols	ARP, IP/ICMP, TCP, UDP, Telnet, DHCP client, Modbus/TCP
Security	User ID & Password
	IP address filtering
Management	Telnet or serial console port or HelloDevice Manager
	Full-featured system status display
	Firmware upgrade via serial console or telnet
Diagnostic LED	Power Ready 10 Base-T Link, Act Serial Rx/Tx
Power	Supply voltage: 7.5 ~ 30 VDC
	Supply current: 350 mA max.
Environmental	Operating temperature: 0 ~ 55 °C Storage temperature: -4 ~ 66 °C
Physical properties	Size: 100 mm L 50 mm W 68 mm H (3.9 in x 2.0 in x 2.7 in)
	Weight: 290g
Approvals	FCC(A), CE(A), MIC
Warranty	5-year limited warranty

1.4 Terminologies and acronyms

The Internetworking related terminologies used frequently in this manual are defined clearly to help your better understanding of the IALink100-Modbus.

MAC address

On a local area network or other network, the MAC (Media Access Control) address is the computer's unique hardware number. (On an Ethernet LAN, it's the same as your Ethernet address.)

It is a unique 12-digit hardware number, which is composed of 6-digit OUI (Organization Unique Identifier) number and 6-digit hardware identifier number. The IALink100-Modbus has the MAC address of 00-01-95-xx-xx-xx, which is labeled on the bottom side of the external box.

Host

A user's computer connected to the network

In Internet protocol specifications, the term "host" means any computer that has full two-way access to other computers on the Internet. A host has a specific "local or host number" that, together with the network number, forms its unique IP address.

Session

A series of interactions between two communication end points that occur during the span of a single connection

Typically, one end point requests a connection with another specified end point and if that end point replies agreeing to the connection, the end points take turns exchanging commands and data ("talking to each other"). The session begins when the connection is established at both ends and terminates when the connection is ended.

Client/Server

Client/server describes the relationship between two computer programs in which one program, the client, makes a service request from another program, the server, which fulfills the request.

A server is a computer program that provides services to other computer programs in the same or other computers, whereas a client is the requesting program or user in a client/server relationship. For example, the user of a Web browser is effectively making client requests for pages from servers all over the Web. The browser itself is a client in its relationship with the computer that is getting and returning the requested HTML file. The computer handling the request and sending back the HTML file is a server.

Table 1-1 Acronym Table

ISP	Internet Service Provider
PC	Personal Computer
NIC	Network Interface Card
MAC	Media Access Control
LAN	Local Area Network
UTP	Unshielded Twisted Pair
ADSL	Asymmetric Digital Subscriber Line
ARP	Address Resolution Protocol
IP	Internet Protocol
ICMP	Internet Control Message Protocol
UDP	User Datagram Protocol
TCP	Transmission Control Protocol
DHCP	Dynamic Host Configuration Protocol
SMTP	Simple Mail Transfer Protocol
FTP	File Transfer Protocol
PPP	Point-To-Point Protocol
PPPoE	Point-To-Point Protocol over Ethernet
HTTP	HyperText Transfer Protocol
DNS	Domain Name Service
SNMP	Simple Network Management Protocol
UART	Universal Asynchronous Receiver/Transmitter
Bps	Bits per second (baud rate)
DCE	Data Communications Equipment
DTE	Data Terminal Equipment
CTS	Clear to Send
DSR	Data Set Ready
DTR	Data Terminal Ready
RTS	Request To Send

2: Getting Started

This chapter describes how to set up and configure the IALink100-Modbus in the first place.

- 2.1 *Panel Layout* explains the layout of the panel and LED indicators.
- 2.2 *Connecting the Hardware* describes how to connect the power, the network, and the Modbus serial device to the IALink100-Modbus .
- 2.3 *Accessing Console Port* describes how to access the console port using a serial console at a local site or telnet console at a remote site.

Following items are pre-required to get started.

- DC power source (+7.5 ~ 30 VDC).
- One serial console cable for configuration
- One serial data cable for connecting the RS-232/422/485 serial device.
- One PC with Network Interface Card (hereafter, NIC) and/or one RS232 serial port.
- Terminal emulation program running on the PC
- One Ethernet cable

2.1 Panel Layout

The IALink100-Modbus has six LED indicator lamps for status display as shown in Figure 2-1. Two lamps on the upper side indicate the system running status and the system power-on status. Next two lamps below indicate statuses of 10 Base-T Ethernet Link and Act. The other lamps indicate statuses of receive and transmit of the serial port for data communication. Table 2-1 describes function of each LED indicator lamp.

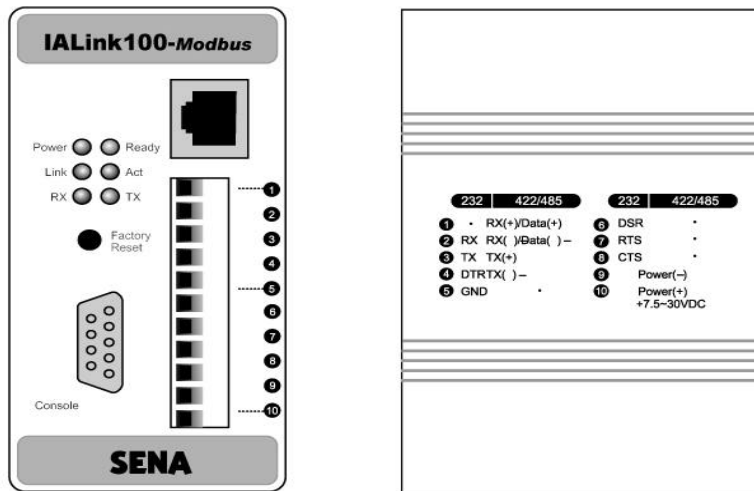

Figure 2-1. The panel layout of the IALink100-Modbus

Table 2-1. LED indicator lamps of the IALink100-Modbus

Lamps		Function
10 Base-T	LINK	Turned on to Green if connected to 10 Base-T Ethernet network
	Rx/Tx	Blink whenever there is any activities such as incoming or outgoing packets through the IALink100-Modbus Ethernet port
Serial port	Rx/Tx	Blink whenever there is any incoming or outgoing data stream through the serial port of the IALink100
Status	Ready	Turned on to GREEN if system is running.
	Power	Turned on to RED if power is supplied

2.2 DIN Rail Mounting

The IALink100-Modbus has a DIN-rail mounting adaptor on the back of the case, which is a most common mounting method for the industrial automation applications. Installation and removal of the IALink100-Modbus with a DIN rail are shown in Figure 2-2.

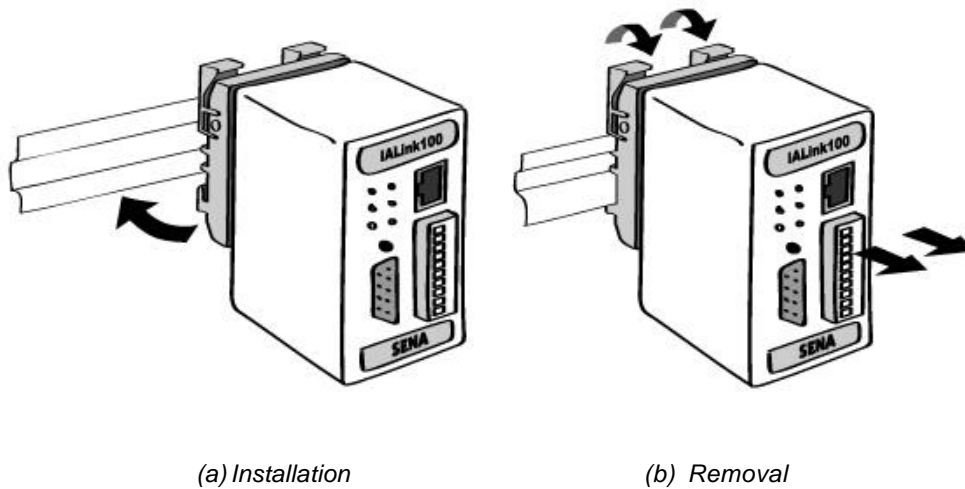

Figure 2-2 Installation and removal of the IALink100-Modbus with a DIN rail

2.3 Connecting the Hardware

This section describes how to connect the IALink100-Modbus to serial devices for the first time test.

- Connect the power to the IALink100-Modbus
- Connect the Ethernet cable between the IALink100-Modbus and Ethernet hub or switch
- Connect the serial data cable between the IALink100-Modbus and serial device(s)

2.3.1 Connecting the power

User can supply DC power to the IALink100-Modbus using the terminal block interface of the

IALink100. Connect the power cable to the 9th and 10th pins of the terminal block of the IALink100-Modbus using users' own DC power supply. Please refer to the *Appendix A* for terminal block pin outs and their descriptions. If the power is properly supplied, the [Power] lamp will maintain solid red.

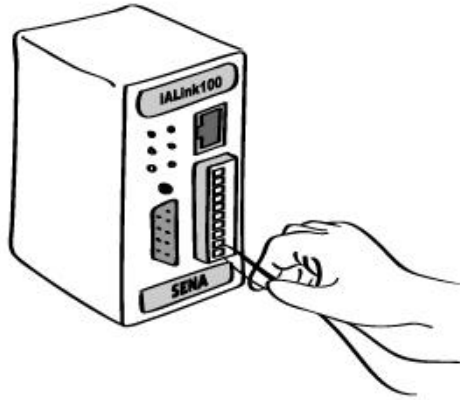

Figure 2-3. Connecting the power to the IALink100-Modbus

2.3.2 Connecting to the network

Connect the one end of the Ethernet cable to the IALink100-Modbus 10Base-T port and the other to the Ethernet network. If the cable is properly hooked up, the IALink100-Modbus will have a valid connection to the Ethernet network by indicating :

- [Link] lamp maintains solid green
- [Act] lamp continuously blinks to indicate the incoming/outgoing Ethernet packets

If any of the above does not happen, the IALink100-Modbus is not properly connected to the Ethernet network.

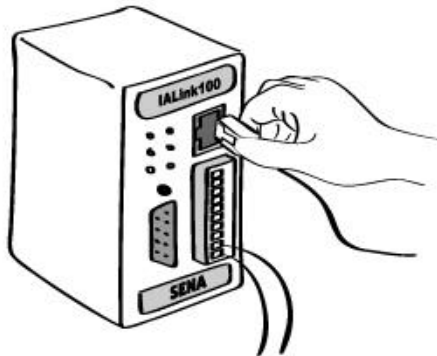

Figure 2-4. Connecting a network cable to the IALink100-Modbus

2.3.3 Connecting to the device

Connect the serial data cable between the IALink100-Modbus and the serial device using the 1st ~ 8th pins of the terminal block interface of the IALink100-Modbus. Please refer to the *Appendix A* for terminal block pin outs and their descriptions. If necessary, supply the power to the serial device attached to the IALink100-Modbus.

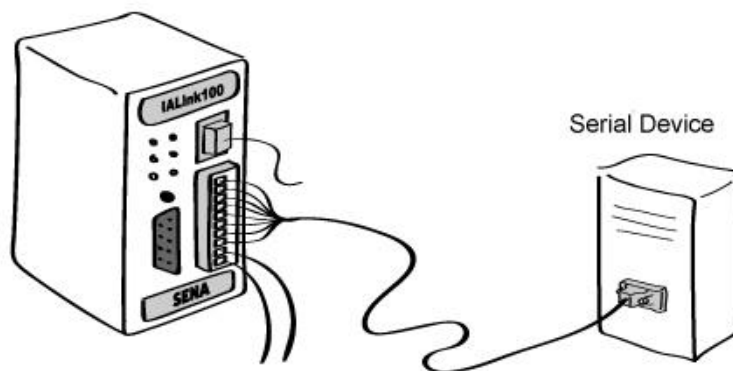

Figure 2-5. Connecting a serial device to the IALink100-Modbus

2.4 Accessing Console Port

There are two ways to access console port of the IALink100-Modbus depending on whether the user is located at a local site or a remote site.

- Serial console:

Local users can connect directly to the serial console port of the IALink100-Modbus using serial console cable (null-modem cable).

- Remote console:

Remote users can make a telnet connection to the remote console port (port 23) of the IALink100-Modbus via TCP/IP network.

Both methods require the user to log into the IALink100-Modbus in order to continue .

2.4.1 Using Serial console

- 1) Connect the one end of the serial console cable to the console port on the IALink100-Modbus.



Figure 2-6. Connecting a serial console cable to the IALink100-Modbus

- 2) Connect the other end of the cable to the serial port of user's computer.
- 3) Run a terminal emulator program such as HyperTerminal. Set up the serial configuration parameters of the terminal emulation program as follows:
9600 Baud rate, Data bits 8, Parity None, Stop bits 1, Hardware flow control (RTS/CTS)
- 4) Press [ENTER] key.
- 5) Type the user name and password to log into the IALink100-Modbus. A factory default setting of the user name and password are both **admin**.

```
login : admin  
password : *****
```

- 6) If the user logged into the IALink100-Modbus successfully, the main menu screen will appear on the computer.

From the main menu screen, shown below in Figure 2-7, users can select the menu item for the configuration of the IALink100-Modbus parameters by typing the menu number and pressing [ENTER] key. In the submenu screen, users can configure the required parameters guided by online comments. All the parameters are stored into the non-volatile memory space of the IALink100-Modbus, and it will not be stored until users select menu *4.Save changes*. When users are finished with the configuration, the system needs to be rebooted by selecting the menu *6.Exit and reboot*. All the configuration changes will be effective after the reboot.

```
-----  
                          Welcome to IALink100-Modbus TCP configuration page  
-----  
Model No.   : IALink100-Modbus      Serial No.  : IALINK-020800012  
F/W Rev.    : V1.0.8                MAC Address : 00-01-95-04-1C-EC  
IP Mode     : Static IP              IP Address  : 192.168.0.152  
Modbus Mode : Master / RTU           UART        : 9600-8-1-None  
-----  
Select menu  
1. IP Configuration  
2. Modbus configuration  
3. System Administration  
4. Save changes  
5. Exit without reboot  
6. Exit and reboot  
  <ESC> Back, <ENTER> Refresh  
----->
```

Figure 2-7. The main menu screen

2.4.2 Using Remote console

The IP address of the IALink100-Modbus must be known before users can access the remote console port (See **IP Address Configuration** in chapter 3 for details). Remote console access function is optional, and can be disabled in the remote access option on the menu (See **Remote Host Access Control** in section 5.1 for details). This is useful when system administrator does not want others to modify the existing configuration. The IALink100-Modbus supports Telnet protocol for remote consoles and the port number for the remote console is 23, which is a TCP port number assigned for Telnet.

- 1) Run a telnet program or a program that supports telnet functions such as TeraTerm-Pro or HyperTerminal. The target IP address and the port number should be those of the IALink100-Modbus. If required, specify the port number as 23. Type the following command in the command line interface of your computer.

```
telnet 192.168.1.254
```

Or run a telnet program with parameters as follows.

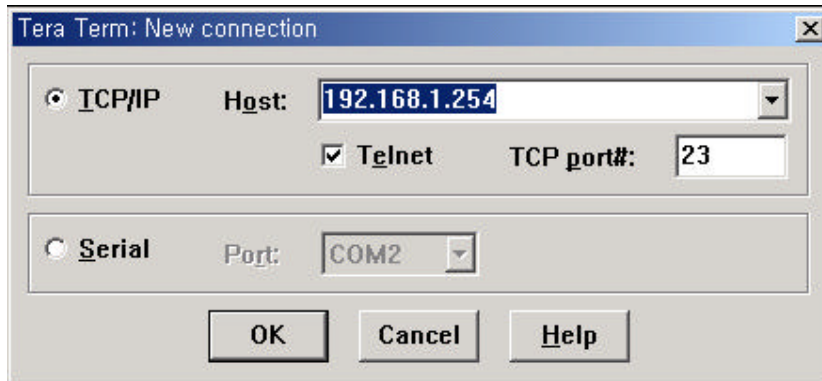

Figure 2-8 Telnet program set up example

- 2) The user has to log into the IALink100-Modbus. Type the user name and password. A factory default setting of the user name and password are both **admin**.

```
login : admin
password : *****
```

Figure 2-9. Users' logging into the IALink100-Modbus

- 3) If the user logged into the IALink100-Modbus successfully, the same main menu screen as the one of serial console will be displayed. The user can select the menu by typing the menu number and then pressing [ENTER] key. In the corresponding menu screen, the user can configure the required parameters.
- 4) If the serial console is established while remote console is connected, remote console will display the message of "Serial console is established. Remote console will not work any more", and will be disconnected after 10 seconds.

3: IP Address Configuration

A valid IP address of the IALink100-Modbus needs to be assigned before it starts to work in the user's network environment. A network system administrator may provide the user with this IP address setting information for the network. The IP address must be unique within the network. Otherwise, the IALink100-Modbus will not have a valid connection to the network.

Users can choose the desired IP mode out of Static IP and DHCP. The factory default IP mode is **DHCP** mode. Table 3-1 shows the parameter items for **IP Configuration** menu.

Table 3-1. Hierarchical view of the IP Configuration menu items

Static IP	IP mode
	IP address
	Subnet mask
	Default gateway
DHCP	IP mode

3.1 Static IP

3.1.1 Overview

In the **Static IP** mode, users have to manually specify all the parameters such as IP addresses of the IALink100-Modbus, the gateway computer and the domain name server computers, and the network subnet mask. The IALink100-Modbus tries to locate such information whenever it boots up.

The user interface for **Static IP configuration** is shown below in Figure 3-1. Users can select menu by typing the menu number and then pressing [ENTER] key.

```
-----  
IP configuration  
-----  
Select menu  
1. IP mode           : Static IP  
2. IP address        : 192.168.0.195  
3. Subnet mask       : 255.255.255.0  
4. Default gateway   : 192.168.1.1  
  <ESC> Back, <ENTER> Refresh  
----->
```

Figure 3-1. Static IP configuration screen

3.1.2 IP address

In the **Static IP** mode, the IP address is an identification number assigned to a computer as a permanent address on the network. Computers use IP addresses to identify and talk to each other on

the network. Choose the proper IP address which is unique and valid on the network environment.

```
---> 2  
Enter IP address: 192.168.1.100[ENTER]
```

Figure 3-2. Setting the IP address in Static IP mode

Note:

The IP address in the form of 192.168.x.x is private in a sense that they are not assigned by an ISP. Application of the IALink100-Modbus may require sending data back and forth over a public network, such as the Internet. In this case, it is required to assign a valid public IP address. The public IP address is generally purchased or leased from a local ISP.

3.1.3 Subnet mask

A subnet represents all the network hosts at one geographic location, in one building, or on the same local area network. When there is any outgoing packet over the network, the IALink100-Modbus will check whether the desired TCP/IP host specified in the packet is on the local network segment with the help of the subnet mask. If the address is proven to be on the same network segment as the IALink100-Modbus, the connection is established directly from the IALink100-Modbus. Otherwise, the connection is established through the given default gateway.

```
---> 3  
Enter subnet mask: 255.255.255.0[ENTER]
```

Figure 3-3. Setting the sub net mask in Static IP mode

3.1.4 Default gateway

A gateway is a network point that acts as an entrance to another network. Usually, the computers that control traffic within the network or at the local Internet service provider are gateway nodes. The IALink100-Modbus needs to know the IP address of the default gateway computer in order to communicate with the hosts outside the local network environment. For correct information on the gateway IP address, please refer to the network administrator.

```
---> 4  
Enter default gateway: 192.168.1.1[ENTER]
```

Figure 3-4. Setting the default gateway in Static IP mode

3.2 DHCP

3.2.1 Overview

Dynamic Host Configuration Protocol (DHCP) is a communications protocol that lets network administrators manage and automate the assignment of IP addresses centrally in an organization's network. DHCP lets a network administrator supervise and distribute IP addresses from a central point and automatically send a new IP address when a computer is plugged into a different place in the network.

As described in the section 3.1, the IP address must be entered manually at each computer in Static IP mode and, if computers move to another location in another part of the network, a new IP address must be entered. Meanwhile, all the parameters including the IP address, subnet mask, gateway will be automatically configured when the IP address is assigned in DHCP mode. DHCP uses the concept of a "lease" or amount of time for which a given IP address will be valid for a computer. All the parameters required to assign an IP address are configured on DHCP server side, and each DHCP client computer receives this information when the IP address is provided at its boot-up.

To obtain an IP address, the IALink100-Modbus sends a corresponding DHCP request as a broadcast over the network after each reset. The reply generated by the DHCP server contains the IP address as well as the subnet mask, gateway address and the lease time. The IALink100-Modbus immediately places this information in its non-volatile memory. If the operating time reaches the lease time, the IALink100-Modbus will request the DHCP server for renewal of its lease time. If the DHCP server approves extending the lease, the IALink100-Modbus can continue to work with the current IP address. Otherwise, the IALink100-Modbus will start the procedure to request a new IP address to the DHCP server.

A DHCP server assigns IP addresses dynamically from an IP address pool, which is managed by the network administrator. This means DHCP client, i.e. the IALink100-Modbus, receives a different IP address each time it boots up. To prevent the case that users do not know the IP address of the IALink100-Modbus in such environments, its IP address should be reserved on the DHCP server side. In order to reserve the IP address in the DHCP network, the administrator needs the MAC address of the IALink100-Modbus found on the label sticker at the side of the IALink100-Modbus:

MAC=00:01:95:04:0c:a1

3.2.2 DHCP setting

In DHCP mode, no additional parameters are required to be set. Just set IP mode as a DHCP mode.

```
-----  
IP configuration  
-----  
Select menu  
1. IP mode           : Static IP  
2. IP address        : 192.168.0.195  
3. Subnet mask       : 255.255.255.0  
4. Default gateway   : 192.168.1.1  
  <ESC> Back, <ENTER> Refresh  
-----> 1  
Enter IP mode (Static IP = 1, DHCP = 2): 2
```

Figure 3-5. Setting DHCP mode

4: Modbus Configuration

Modbus configuration screen can be reached through menu 2 in the main menu screen. In Modbus configuration menu, users can configure Modbus-related parameters and serial port configuration parameters. The figure 4-1 shows the initial screen of Modbus configuration menu and Table 4-1 shows the hierarchical view of the Modbus configuration items and sub menus.

```

-----
Modbus configuration
-----
Select menu
1. Serial communication type : RS232
2. Modbus/Serial mode : RTU
3. Baud rate : 9600
4. Data bits : 8
5. Parity : None
6. Stop bits : 1
7. RTU frame timeout[ms]: 1000
8. Attached serial device : Master
9. UnitID/IP address lookup table
   <ESC> Back, <ENTER> Refresh
----->

```

Figure 4-1. Initial screen of Modbus configuration

Table 4-1. Hierarchical view of the Modbus Configuration menu items

Serial communication type	RS232 / RS485 / RS422
Modbus/serial mode	RTU / ASCII
Baudrate	1200/2400/4800/9600/19200/38400/57600/115200
Data bits	7 bits / 8 bits
Parity	None / Even / Odd
Stop bits	1 bit / 2 bits
RTU frame timeout[ms]	100 ~ 65535 ms
Attached serial device	Master / Slave
Unit ID/IP address lookup table	Add Unit ID/IP address lookup table
	Delete Unit ID/IP address lookup table

4.1 Serial communication type

The IALink100-Modbus and the Modbus serial device must agree on the serial communication type, which is one of RS232, RS485 or RS422. The IALink100-Modbus serial port is configured for RS232 communication as a factory default, but it can also be configured for RS422 and RS485 communication. To change the serial communication type, set up the mode in the *Serial communication type* menu. See Appendix B for serial port connections for each serial communication type.

```
-----  
Modbus configuration  
-----  
Select menu  
1. Serial communication type : RS232  
2. Modbus/Serial mode : ASCII  
3. Baud rate : 9600  
4. Data bits : 8  
5. Parity : None  
6. Stop bits : 1  
7. ASCII frame timeout[ms]: 100  
8. Attached serial device : Master  
9. UnitID/IP address lookup table  
   <ESC> Back, <ENTER> Refresh  
-----> 1  
Select serial communication type (1 = RS232, 2 = RS485, 3 = RS422): 2
```

Figure 4-2. Set up Serial communication type

4.2 Modbus/Serial mode

Users can select the Modbus/serial mode between RTU mode and ASCII mode. If the serial device to be used with IALink100-Modbus is using Modbus/RTU mode, select RTU mode. If the serial device is using Modbus/ASCII mode, select ASCII mode. If the serial device supports both of the Modbus/ASCII and Modbus/RTU, select the same mode for the serial device and the IALink100-Modbus.

```
-----  
Modbus configuration  
-----  
Select menu  
1. Serial communication type : RS485  
2. Modbus/Serial mode : ASCII  
3. Baud rate : 9600  
4. Data bits : 8  
5. Parity : None  
6. Stop bits : 1  
7. ASCII frame timeout[ms]: 100  
8. Attached serial device : Master  
9. UnitID/IP address lookup table  
   <ESC> Back, <ENTER> Refresh  
-----> 2  
Select Modbus/serial mode (1 = ASCII, 2=RTU): 2
```

Figure 4-3 Set up the Modbus/serial mode

4.3 Baud rate

The valid baud rate for the IALink100-Modbus is as follows.

1200, 2400, 4800, 9600, 14400, 19200, 38400, 57600 and 115200

The baud rate can be changed by selecting the menu of *Modbus configuration - Baud rate*.

```
-----  
Modbus configuration  
-----  
Select menu  
1. Serial communication type : RS485  
2. Modbus/Serial mode : ASCII  
3. Baud rate : 9600  
4. Data bits : 8  
5. Parity : None  
6. Stop bits : 1  
7. ASCII frame timeout[ms]: 100  
8. Attached serial device : Master  
9. UnitID/IP address lookup table  
  <ESC> Back, <ENTER> Refresh  
-----> 3  
Select baud rate  
  1 = 1200, 2 = 2400, 3 = 4800, 4 = 9600  
  5 = 19200, 6 = 38400, 7 = 57600, 8 = 115200  
  
-----> 5
```

Figure 4-4. Set up the baud rate

4.4 Data bits, Stop bits, Parity

The factory default setting of the *data bits*, *stop bits* and *parity* are *8*, *1* and *None*. They can be changed using the menu 3, 4 and 5.

```
-----  
Modbus configuration  
-----  
Select menu  
1. Serial communication type : RS485  
2. Modbus/Serial mode : ASCII  
3. Baud rate : 9600  
4. Data bits : 8  
5. Parity : None  
6. Stop bits : 1  
7. ASCII frame timeout[ms]: 100  
8. Attached serial device : Master  
9. UnitID/IP address lookup table  
  <ESC> Back, <ENTER> Refresh  
-----> 4  
Select data bits (1 = 7 bits, 2 = 8 bits) : 2  
  
( or  
-----> 5  
Select parity (1 = None, 2 = Even, 3 = Odd) : 1  
  or  
-----> 6  
Select stop bits (1 = 1 bit , 2 = 2 bits) : 1  
)
```

Figure 4-5. Set up the data bits, stop bits, parity

4.5 RTU/ASCII frame timeout

This parameter defines the response timeout to a Modbus query command. If the Modbus device does not respond to the query during this time interval, the query will be handled as a timeout error.

RTU/ASCII frame timeout is defined in millisecond units, and the allowed values are 100 ~ 65535 ms.

```
-----  
Modbus configuration  
-----  
Select menu  
1. Serial communication type : RS485  
2. Modbus/Serial mode : ASCII  
3. Baud rate : 9600  
4. Data bits : 8  
5. Parity : None  
6. Stop bits : 1  
7. ASCII frame timeout[ms]: 100  
8. Attached serial device : Master  
9. UnitID/IP address lookup table  
   <ESC> Back, <ENTER> Refresh  
-----> 7  
Enter Timeout[ms]:1000
```

Figure 4-6. Set up the RTU/ASCII frame timeout

4.6 Attached Modbus serial device type

The Modbus serial device attached to the IALink100-Modbus can be any of Modbus master or Modbus slave. If the device attached is a Modbus slave, IALink100-Modbus waits for the Modbus query from the Modbus/TCP master. If the query is received, IALink100-Modbus converts the Modbus/TCP to Modbus/Serial data and transfers it to the device. If the response is received from the Modbus serial device, the IALink100-Modbus converts it for the Modbus/TCP data, and sends it to the Modbus/TCP master.

In case that the device attached is a Modbus master, IALink100-Modbus waits for the Modbus query from the device. If the query is received, IALink100-Modbus converts the query to the Modbus/TCP packet and sends it to the corresponding IP address using the *Unit ID/IP address lookup table* that will be explained in the next section. If the Modbus/TCP response for the query is received, converts it as a Modbus/serial data, transfers it to the serial device.

```
-----  
Modbus configuration  
-----  
Select menu  
1. Serial communication type : RS485  
2. Modbus/Serial mode : ASCII  
3. Baud rate : 9600
```



```

4. Data bits : 8
5. Parity : None
6. Stop bits : 1
7. ASCII frame timeout[ms]: 100
8. Attached serial device : Master
9. UnitID/IP address lookup table
   <ESC> Back, <ENTER> Refresh
-----> 8
Select Modbus mode (1=MASTER, 2=SLAVE) : 2

```

Figure 4-7. Set up the attached serial device type

4.7 Unit ID / IP address lookup table

If the device attached is a Modbus master, the IALink100-Modbus has to know which IP address is for the Modbus/TCP slave of corresponding Modbus node ID, and users have to provide those information manually.

Unit ID/IP address lookup table consists of IP address and corresponding Modbus node IDs sets. To add a lookup table element, select menu 9. *Unit ID/IP address lookup table* and select submenu 1. *Add Unit ID/IP address lookup table*. Enter the IP address to add and then start and end of Modbus Unit ID of the IP address.

To remove a lookup table element, select menu 9. *Unit ID/IP address lookup table* and select submenu 2. *Delete Unit ID/IP address lookup table*. Enter the IP address to remove and then start and end of Modbus Unit ID of the IP address.

Note:

Unit ID/IP address lookup table is displayed only if the attached serial device is selected to be a Master.

```

-----
Modbus configuration
-----
Select menu
1. Serial communication type : RS485
2. Modbus/Serial mode : ASCII
3. Baud rate : 9600
4. Data bits : 8
5. Parity : None
6. Stop bits : 1
7. ASCII frame timeout[ms]: 100
8. Attached serial device : Master
9. UnitID/IP address lookup table
   <ESC> Back, <ENTER> Refresh
-----> 9
-----

Unit ID/IP address lookup table

NO.      IP address          UnitID
-----
Select menu

```

```
1. Add Unit ID/IP address lookup table
2. Delete Unit ID/IP address lookup table
-----> 1
Enter IP address : 192.168.100.100
Enter start Unit ID : 1
Enter end Unit ID : 5
```

Unit ID/IP address lookup table

NO.	IP address	UnitID
0	192.168.100.100	1, 2, 3, 4, 5,

Select menu

```
1. Add Unit ID/IP address lookup table
2. Delete Unit ID/IP address lookup table
-----> 2
Enter IP address : 192.168.100.100
Enter start Unit ID : 3
Enter end Unit ID : 5
```

Unit ID/IP address lookup table

NO.	IP address	UnitID
0	192.168.100.100	1, 2,

Select menu

```
1. Add Unit ID/IP address lookup table
2. Delete Unit ID/IP address lookup table
----->
```

Figure 4-8. Add/Delete Unit ID/IP address lookup table

5: System administration

Users can configure system administration parameters by selecting menu *3.System administration* in the main menu screen. In this menu, users can configure remote host access control, administrator username, and password and update the firmware.

```
-----  
System Administration.  
-----  
1. Remote configuration by telnet : Enable  
2. Allowed remote hosts for configuration : Any  
3. Administrator username : admin  
4. Administrator password : *****  
5. Firmware upgrade  
  <ESC> Back, <ENTER> Refresh  
----->
```

Figure 5-1 System administration initial screen

5.1 Remote host access control

The IALink100-Modbus has an IP address based filtering method to control the access to the telnet from the remote hosts to prevent unauthorized access. You can allow one of the following cases by setting the parameter.

- Only one host of specific IP address can access the IALink100-Modbus
- Hosts on the specific subnet can access the IALink100-Modbus
- Any host can access the IALink100-Modbus

The IALink100-Modbus remote console access feature can be enabled or disabled by selecting submenu *1.Remote configuration by Telnet*. Factory default setting of this feature is “Enabled”. If the remote configuration feature is enabled, you can specify a host or hosts allowed to access the IALink100-Modbus for configuration by selecting submenu *2.Allowed remote hosts for configuration*. When you select this menu, you have to enter the IP address or subnet to be allowed to access the IALink100-Modbus in the format of “subnet or IP address/subnet mask”. If you want to allow only a specific host to access the IALink100-Modbus for configuration, enter “IP address/255.255.255.255” such as 192.168.1.100/255.255.255.255. If you want to allow any hosts on the specified subnet, enter “subnet/subnet mask” such as “192.168.1.0/255.255.255.0”. If you want to allow any host, enter “0.0.0.0/0.0.0.0”. Please refer to Table 5-1 for more details. Default setting of allowable remote hosts for configuration is “Any”.

Table 5-1 Input examples of allowed remote hosts

Allowable Hosts	Input format
Any host	0.0.0.0/0.0.0.0
192.168.1.120	192.168.1.120/255.255.255.255
192.168.1.1 ~ 192.168.1.254	192.168.1.0/255.255.255.0
192.168.0.1 ~ 192.168.255.254	192.168.0.0/255.255.0.0
192.168.1.1 ~ 192.168.1.126	192.168.1.0/255.255.255.128
192.168.1.129 ~ 192.168.1.254	192.168.1.128/255.255.255.128

```

-----
System Administration.
-----
1. Remote configuration by telnet : Enable
2. Allowed remote hosts for configuration : Any
3. Administrator username : admin
4. Administrator password : *****
5. Firmware upgrade
   <ESC> Back, <ENTER> Refresh
-----> 1
Do you want to allow remote configuration by telnet? (y/n): y

-----
System Administration.
-----
1. Remote configuration by telnet : Enable
2. Allowed remote hosts for configuration : Any
3. Administrator username : admin
4. Administrator password : *****
5. Firmware upgrade
   <ESC> Back, <ENTER> Refresh
-----> 2
Enter IP address of hosts or network allowed to access
Format) IP-address/subnet-mask
Ex1) 192.168.1.0/255.255.255.0 to allow hosts of 192.168.1.*
Ex2) 192.168.1.99/255.255.255.255 to allow hosts of 192.168.1.99
Ex3) 0.0.0.0 / 0.0.0.0 to allow any remote host
-----> 192.168.2.100/255.255.255.255

```

Figure 5-2 Set up the remote console access

5.2 User name and password

Users can change the administrator's username and password, as they want. The maximum character length for the both is 31. The default settings of username and password are both "admin".

```

-----
System Administration.
-----
1. Remote configuration by telnet : Enable

```

```
2. Allowed remote hosts for configuration : Any
3. Administrator username : admin
4. Administrator password : *****
5. Firmware upgrade
  <ESC> Back, <ENTER> Refresh
-----> 3
Enter current password : *****
Enter New username      : admin2

-----
System Administration.
-----
1. Remote configuration by telnet : Enable
2. Allowed remote hosts for configuration : Any
3. Administrator username : admin2
4. Administrator password : *****
5. Firmware upgrade
  <ESC> Back, <ENTER> Refresh
-----> 4
Enter current password : *****
Enter New password     : *****
Retype password        : *****
```

Figure 5-3 Set up the user name and password

5.3 Firmware upgrade

Firmware of the IALink100-Modbus can be upgraded both by serial console or remote console. The latest firmware can be obtained from our web site: <http://www.sena.com/support/downloads/>. For firmware upgrade, your terminal emulation program must support Zmodem transfer protocol. After firmware upgrade, previous settings will be reset to factory default settings except IP configuration settings.

Please follow the instructions below for firmware upgrade:

- 1) Obtain the latest firmware.
- 2) Connect your terminal emulation program using serial console or telnet. If you use serial console of the IALink100-Modbus, please remember the setting of the terminal emulation program as follows.
 - 9600 Baud rate, Data bits 8, Parity None, Stop bits 1, Hardware flow control (RTS/CTS)**
- 3) Select firmware upgrade menu.
- 4) Follow the step as guide d by online messages.

```
-----> 5
Are you sure to start firmware upgrade ? (y/n) : y
Preparing for firmware upgrade. Wait a moment...
Transfer firmware by zmodem using your terminal application.
**B01ff000005b157
```

Figure 5-4. Firmware upgrade display

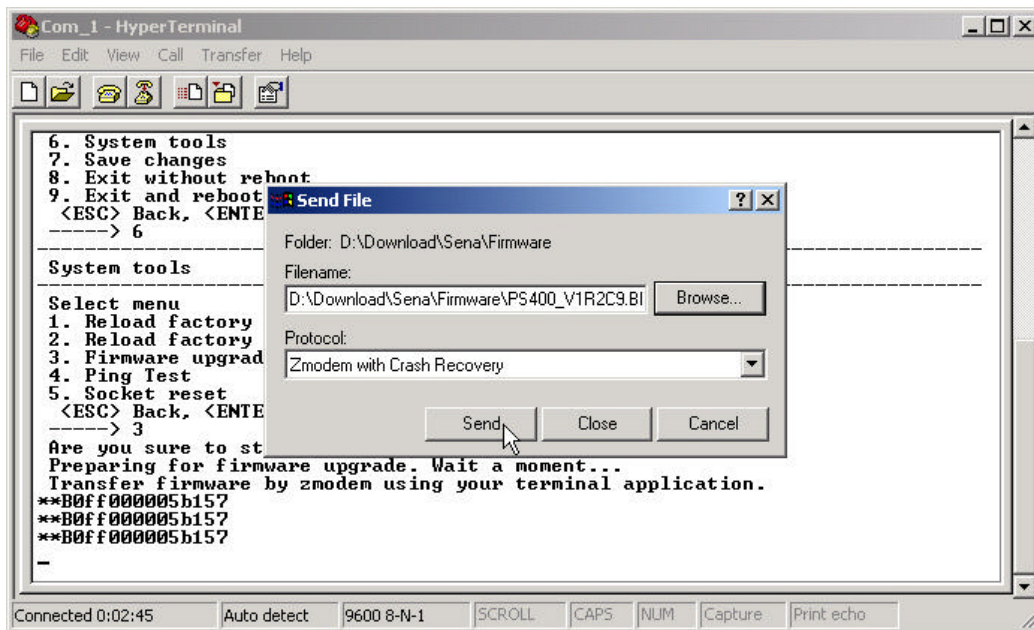

Figure 5-5 Transfer binary file by Zmodem (HyperTerminal)

- 5) If firmware is upgraded successfully, the IALink100-Modbus will reboot automatically.
- 6) If the firmware upgrade fails, the IALink100-Modbus will display messages as follows, and it will preserve the firmware of current version.

```

-----> 5
Are you sure to start firmware upgrade ? (y/n) : y
Preparing for firmware upgrade. Wait a moment...
Transfer firmware by zmodem using your terminal application.
**B01ff000005b157
**B01ff000005b157
**B01ff000005b157
**B01ff000005b157
**B01ff000005b157
Firmware upgrade failure. Recovering the previous firmware...

Recovering completed. Device will reboot in a moment...

```

Figure 5-6. Firmware upgrade failure message

6. Case study

In this chapter, IALink100-Modbus configuration example is provided for better understanding. The example installation diagram is shown as Figure 6-1, the installation network parameters to be assumed are shown in Table 6-1. And Modbus related parameters to be assumed are shown in Table 6-2.

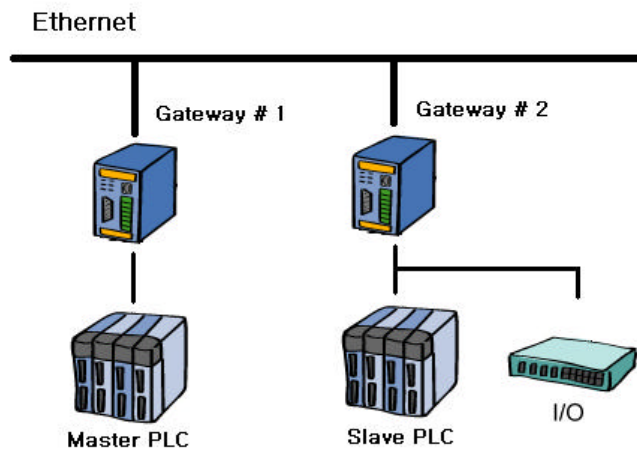

Figure 6 - 1 Example installation diagram

Table 6-1 Example network parameters

	Gateway # 1	Gateway # 2
Default Gateway	192.168.1.1	192.168.1.1
IP address	192.168.10.1	192.168.10.2
Subnetmask	255.255.255.0	255.255.255.0

Table 6-2 Example Modbus parameters

	Master PLC	Slave PLC	I/O
Modbus mode	RTU	ASCII	ASCII
Modbus ID		1	2
Baud rate	19200bps	9600bps	9600bps
Serial type	RS-232	RS-485	RS-485
Data bits	8	7	7
Stop bits	1	2	2
Parity	None	None	None

The following procedures are the one for the configuration of the Gateway #1.

- 1) Connect the IALINK100-Modbus serial console with the COM port of a PC
- 2) Run terminal emulation program on the PC with the settings of **9600 bps, 8 data bits, 1 stop bit, None parity.**
- 3) Login to the IALink100-Modbus console. Factory default settings of the user name and passwords are both admin.
- 4) Perform [IP Configuration] using the values shown in Table 6-3.

Table 6-3 IP configuration parameters for the gateway#1

Parameters	Values
IP mode	Static IP
IP address	192.168.10.1
Subnet mask	255.255.255.0
Default Gateway	192.168.1.1

- 5) Perform [Modbus configuration] using the values shown in Table 6-4.

Table 6-4 Modbus parameters for the gateway#1

Parameters	Values	
Serial communication type	RS232	
Modbus/Serial mode	RTU	
Baud rate	19200	
Data bits	8	
Parity	None	
Stop bits	1	
RTU frame timeout[ms]	1000	
Attached serial device	Master	
Unit ID/IP address lookup table		
Device	ID	IP
Slave PLC	1	192.168.10.2
I/O	2	192.168.10.2

- 6) Save changes selecting the menu [Save changes].
- 7) Reboot the IALink100-Modbus selecting the menu [Exit and reboot].

The following procedures are the one for the configuration of the Gateway #2.

- 1) Connect the IALINK100-Modbus serial console with the COM port of a PC
- 2) Run terminal emulation program on the PC with the settings of **9600 bps, 8 data bits, 1 stop bit, None parity.**
- 3) Login to the IALink100-Modbus console. Factory default settings of the user name

and passwords are both admin.

- 4) Perform [IP Configuration] using the values shown in Table 6-5

Table 6-5 IP configuration parameters for the gateway#2

Parameters	Values
IP mode	Static IP
IP address	192.168.10.2
Subnet mask	255.255.255.0
Default Gateway	192.168.1.1

- 5) Perform [Modbus configuration] using the values shown in Table 6-6.

Table 6-6 Modbus parameters for the gateway#2

Parameters	Values
Serial communication type	RS485
Modbus/Serial mode	ASCII
Baud rate	9600
Data bits	7
Parity	None
Stop bits	2
RTU frame timeout[ms]	1000
Attached serial device	Slave

- 6) Save changes selecting the menu [Save changes].
- 7) Reboot the IALink100-Modbus selecting the menu [Exit and reboot].

Appendix A: Connections

A.1 Ethernet Pin outs

The IALink100-Modbus uses standard Ethernet connector, which is a shielded connector compliant with AT&T258 specifications. Table A-1 shows the pin assignment and the wire color.

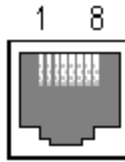

Figure A-1 Pin layout of the RJ45 connector

Table A-1. Pin assignment of the RJ45 connector

Pin	Description	Color
1	Tx+	White with orange
2	Tx-	Orange
3	Rx+	White with green
4	NC	Blue
5	NC	White with blue
6	Rx-	Green
7	NC	White with brown
8	NC	Brown

A.2 Serial Ports Pin Outs

The pin assignment of the IALink100-Modbus terminal block connector is summarized in Table A-2. Each pin has a function according to the serial communication type configuration.

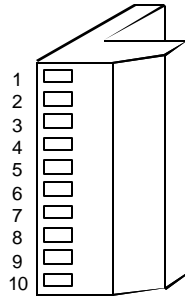

Figure A-2 Pin layout of the terminal block interface connector

Table A-2. Pin assignment of the terminal block interface connector

Pin	RS232	RS422	RS485
1		Rx+	Data+
2	Rx	Rx-	Data-
3	Tx	Tx+	
4	DTR	Tx-	
5	GND		
6	DSR		
7	RTS		
8	CTS		
9	Power (-)		
10	Power (+)		

A.3 Ethernet Wiring Diagram

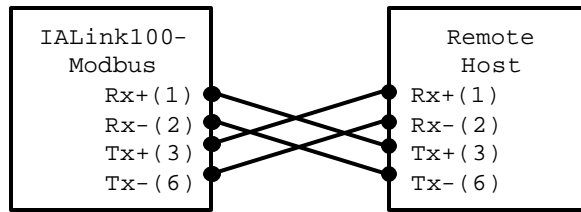

Figure A-3 Ethernet direct connection using crossover Ethernet cable

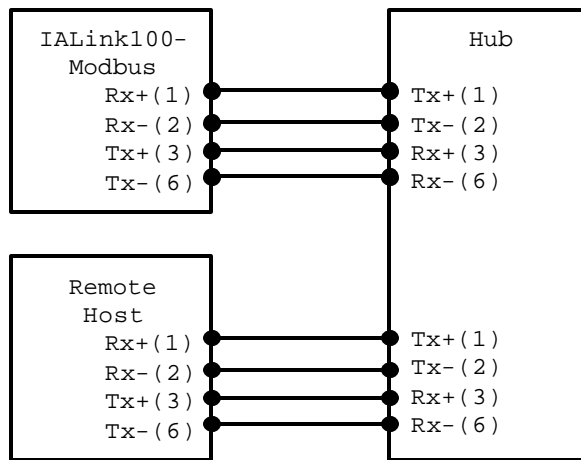

Figure A-4 Ethernet connection using straight through Ethernet cable

A.4 Serial Wiring Diagram

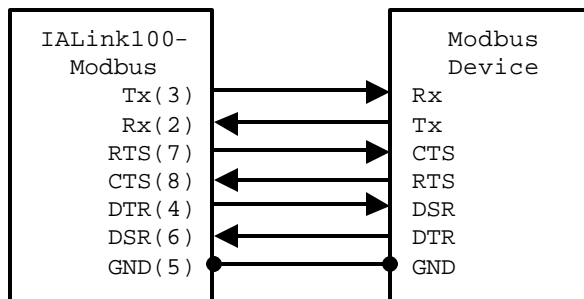

Figure A-5 RS232 wiring diagram

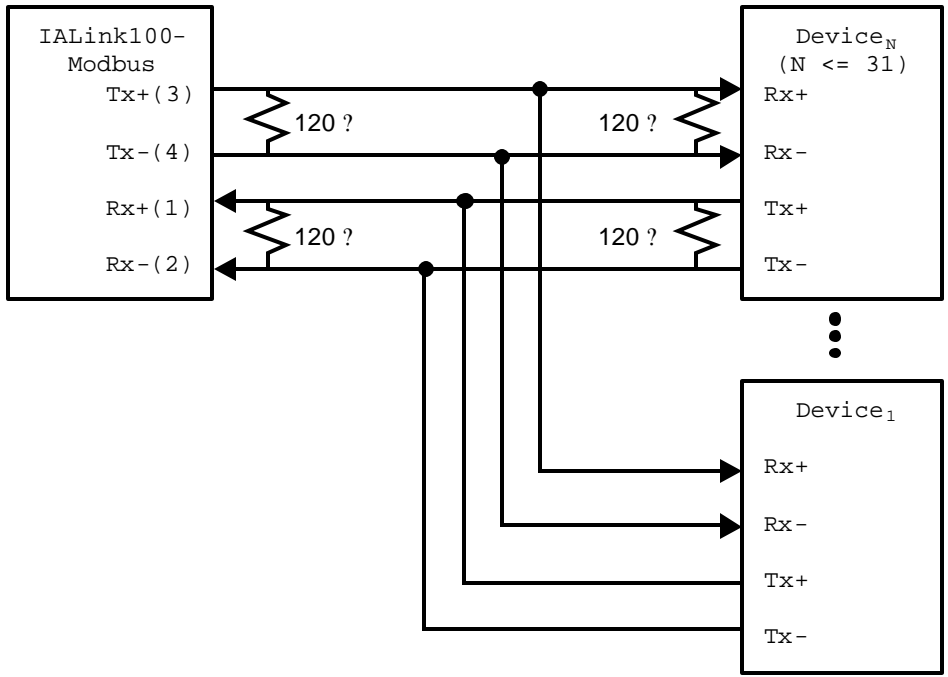

Figure A-6 RS422 wiring diagram

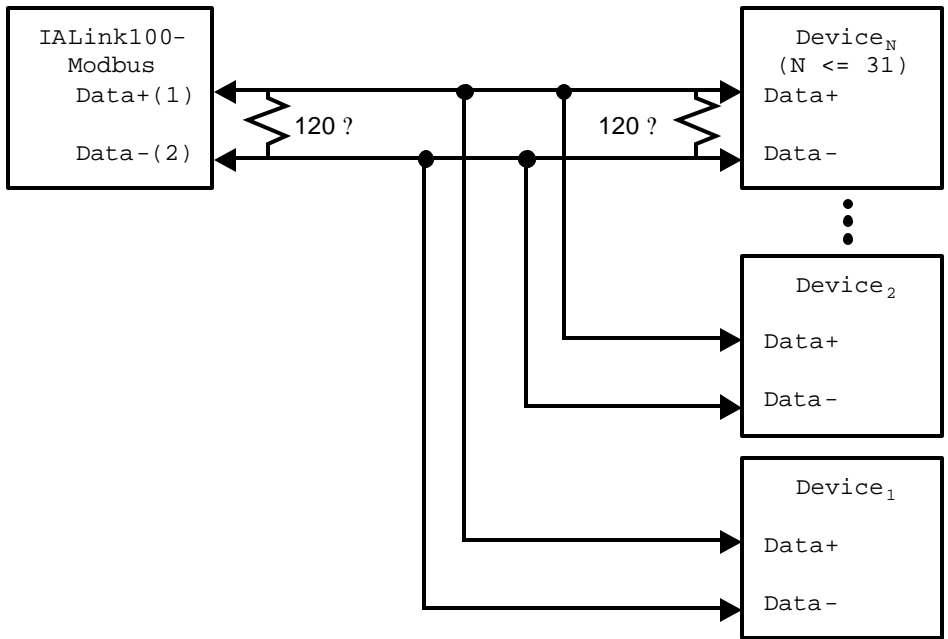

Figure A-7 RS485 wiring diagram

Appendix B: Well-known port numbers

The port numbers are divided into three ranges: the Well Known Ports, the Registered Ports, and the Dynamic and/or Private Ports. The Well Known Ports are those from 0 through 1023. The Registered Ports are those from 1024 through 49151. The Dynamic and/or Private Ports are those from 49152 through 65535.

The Well Known Ports are assigned by the IANA, and on most systems, can only be used by system processes or by programs executed by privileged users. Table B-1 shows famous port numbers among the well-known port numbers. For more details, please visit IANA website:

<http://www.iana.org/assignments/port-numbers>

Table B-1 Well-known port numbers

Port number	Protocol	TCP/UDP
21	FTP (File Transfer Protocol)	TCP
22	SSH (Secure SHell)	TCP
23	Telnet	TCP
25	SMTP (Simple Mail Transfer Protocol)	TCP
37	Time	TCP, UDP
39	RLP (Resource Location Protocol)	UDP
49	TACACS, TACACS+	UDP
53	DNS	UDP
67	BOOTP server	UDP
68	BOOTP client	UDP
69	TFTP	UDP
70	Gopher	TCP
79	Finger	TCP
80	HTTP	TCP
110	POP3	TCP
119	NNTP (Network News Transfer Protocol)	TCP
161/162	SNMP	UDP

Appendix C: Troubleshooting

C.1 Power/LED status troubleshooting

Problem	Cause	Action
Power LED does not light up	Power cable is not connected	Check power connection
Link LED does not light up	Ethernet cable is not connected	Check Ethernet cable connection
	Invalid Ethernet cable is used	There are two types of Ethernet cables: Straight-through cable and crossover cable. If you are using an Ethernet hub, use straight-through cable. If direct connection between the IALink100-Modbus and remote host is used, use crossover cable instead.
ACT LED does not blink	Invalid IP configuration	Check IP configuration parameters

C.2 Serial console troubleshooting

Problem	Cause	Action
Serial console is not connected	Invalid serial cable	Be sure to use a serial console cable (null-modem cable) for serial console
	Invalid serial port configuration of terminal emulation program	Check serial port configuration of terminal emulation program: 9600 bps, 8 Data bits, No parity, 1 stop bit, Hardware flow control
Serial console is halted for few seconds periodically	IP mode is DHCP or PPPoE, but IP is not assigned	If IP mode is set to DHCP but IP is not actually assigned because of DHCP server failure, serial console is halted for few seconds at every 20 seconds. Change IP mode to the static IP mode
Cannot login to console	Invalid username and/or password	Use valid username and password. If username and/or password are lost, perform factory default reset using factory reset switch. Factory default value of username and password are both <i>admin</i>

C.3 Remote console troubleshooting

Problem	Cause	Action
Cannot connect to the IALink100-Modbus using telnet	The IALink100-Modbus is not assigned valid IP address	Use serial console to assign valid IP address to the IALink100-Modbus
	The IALink100-Modbus is configured to reject IP address of the PC	Change the remote host access control parameter using serial console to allow the IP address of the PC
	A remote console is already established	Retry after the remote consoles is finished.
Cannot login to console	Invalid username and/or password	Use valid username and password. If username and/or password are lost, perform factory default reset using factory reset switch. Factory default value of username and password are both <i>admin</i>

C.4 IP address troubleshooting

Problem	Cause	Action
Cannot find IP address of the IALink100-Modbus		Use serial console to find IP address
		Use HelloDeviceManager program to probe the IALink100-Modbus on the network
HelloDeviceManager cannot probe the IALink100-Modbus	The IALink100-Modbus is not assigned valid IP address	Use serial console to assign valid IP address to the IALink100-Modbus
	HelloDeviceManager and the IALink100-Modbus are not on the same subnet	Run HelloDeviceManager on the PC that is on the same subnet with the IALink100-Modbus

C.5 DHCP troubleshooting

Problem	Cause	Action
Cannot lease IP address	DHCP server is not working	Check if DHCP server is working correctly
IP address of the IALink100-Modbus is changed	DHCP server does not extend lease time	Check if DHCP server is working correctly