

# HelloDevice Lite

## LS100

1.2.0

2004-05-21

HelloDevice LS100

1.2.0

1.2.X

Printed in Korea

Copyright 2002~2004, . All rights reserved.

가

HelloDevice(tm) , Inc.

Windows(r) Microsoft Corporation

Ethernet(r) XEROX Corporation

가

210

137-130,

Tel: (+82-2) 573-5422

Fax: (+82-2) 573-7710

E-Mail: support@sena.com

Website: <http://www.sena.com>

1:	.....	5
1.1	.....	5
1.2	.....	6
1.3	.....	7
1.4	.....	8
2:	.....	10
2.1	.....	10
2.2	.....	12
2.2.1	.....	12
2.2.2	.....	12
2.2.3	.....	13
2.3	.....	14
2.3.1	.....	14
2.3.2	.....	16
2.4	.....	17
2.4.1	'set' .....	18
2.4.2	'get' .....	19
2.4.3	'help' .....	20
2.4.4	'factorydefault' .....	21
2.4.5	'save' .....	22
2.4.6	'exit' .....	22
2.4.7	'reboot' .....	22
3: IP	.....	23
3.1	Static IP .....	24
3.1.1	.....	24
3.1.2	Static IP .....	24
3.2	DHCP .....	25
3.2.1	.....	25
3.2.2	DHCP .....	25
3.3	PPPoE .....	26
3.3.1	.....	26
3.3.2	PPPoE .....	26
4.	.....	27
4.1	TCP .....	30
4.1.1	.....	30

4.1.2	TCP	.....	32
4.2	TCP	.....	33
4.2.1		.....	33
4.2.2	TCP	.....	35
4.3	TCP /	.....	36
4.3.1		.....	36
4.3.2	TCP /	.....	38
5:		.....	39
6:		.....	41
A:		.....	42
A.1	Pin Outs	.....	42
A.2	Pin Outs	.....	42
A.3		.....	43
A.4		.....	43
B:		.....	44
C:		.....	45
C.1	/LED	.....	45
C.2		.....	45
C.3		.....	46
C.4	IP	.....	46
C.5	DHCP	.....	46
C.6	TCP	.....	47
C.7		.....	47

1:

1.1

HelloDevice Lite

가

LS100 가

LS100 RS232

LS100 TCP/IP  
LAN( )

LS100

telnet

HelloDevice Manager

LS100 /POS, ,

## 1.2

- HelloDevice LS100
- 110V      230V
- /
- 가
- HD-IDE, HD-VirtualCOM, HD-Manager            가            CD-ROM

### 1.3

	/ DB9 x 1
	1200bps ~ 115200bps
	: None RTS/CTS
	: Rx, Tx, RTS, CTS, DTR, DSR, GND
	10 Base-T (RJ45 )
	IP
	ARP, IP/ICMP, TCP, Telnet, DHCP client, PPPoE
	ID
	Telnet HelloDevice Manager
LED	Power Ready 10 Base-T Link, Rx/Tx
Power	: 7.5V ~ 15V DC
	: 140mA ( )
	: 0 ~ 55 °C : -4 ~ 66 °C
	100 mm L (3.9 in.) 72 mm W (2.8 in.) 29 mm H (1 in.)
	230g
	FCC(A), CE(A), MIC
	5

# 1.4

LS100

MAC

LAN

MAC(Media Access Control)

가

. ( LAN )

6

OUI(Organization Unique Identifier) 6

12

. LS100 MAC 00-01-95-xx-xx-xx ,

" "

가

IP

"가

(" ").

/

/

HTML

HTML



<b>ISP</b>	(Internet Service Provider)
<b>PC</b>	(Personal Computer)
<b>NIC</b>	(Network Interface Card)
<b>MAC</b>	(Media Access Control)
<b>LAN</b>	(Local Area Network)
<b>UTP</b>	(Unshielded Twisted Pair)
<b>ADSL</b>	가 (Asymmetric Digital Subscriber Line)
<b>ARP</b>	(Address Resolution Protocol)
<b>IP</b>	(Internet Protocol)
<b>ICMP</b>	(Internet Control Message Protocol)
<b>UDP</b>	(User Datagram Protocol)
<b>TCP</b>	(Transmission Control Protocol)
<b>DHCP</b>	(Dynamic Host Configuration Protocol)
<b>SMTP</b>	(Simple Mail Transfer Protocol)
<b>FTP</b>	(File Transfer Protocol)
<b>PPP</b>	(Point-To-Point Protocol)
<b>PPPoE</b>	(Point-To-Point Protocol over Ethernet)
<b>HTTP</b>	(HyperText Transfer Protocol)
<b>DNS</b>	(Domain Name Service)
<b>SNMP</b>	(Simple Network Management Protocol)
<b>UART</b>	(Universal Asynchronous Receiver/Transmitter)
<b>Bps</b>	(Universal Asynchronous Receiver/Transmitter)
<b>DCE</b>	(Data Communications Equipment)
<b>DTE</b>	(Data Terminal Equipment)
<b>CTS</b>	가 (Clear to Send)
<b>DSR</b>	(Data Set Ready)
<b>DTR</b>	(Data Terminal Ready)
<b>RTS</b>	(Request To Send)

2:

- 2.1 LS100 LED
- 2.2 LS100
- 2.3 telnet
- 2.4 LS100
- DC ( ) x 1
- ( ) x 1
- RS-232 RS-232 x 1
- ( NIC)가 PC x 1 RS232 x 1
- PC
- x 1

2.1

LS100 5 LED 10 Base-T  
 2 가  
 2-1 LED

2 - 1. LED

10 Base-T	Link	10 Base-T
	Act	LS100
	Rx/Tx	LS100 가
	Ready	
	Power	

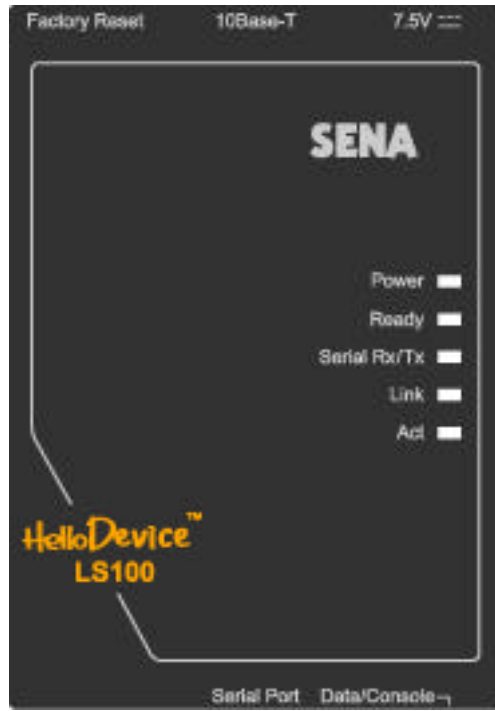

2-1. LS100

## 2.2

LS100

- LS100
- LS100
- LS100

### 2.2.1

DC  
, LS100 [Power]

LS100

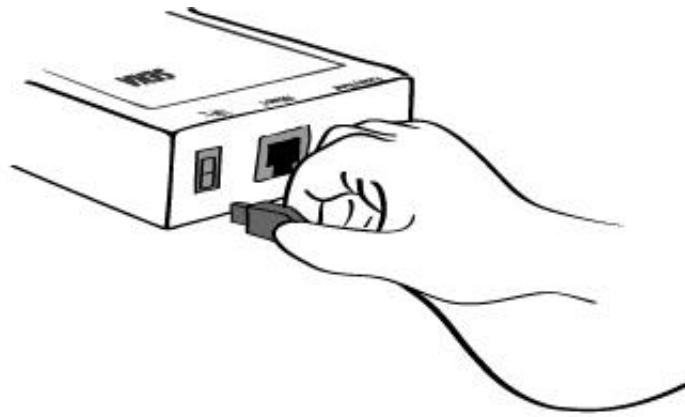

2 - 2. LS100

### 2.2.2

LS100 10Base-T  
, LS100

- LS100 [Link]
- [Act]

LS100

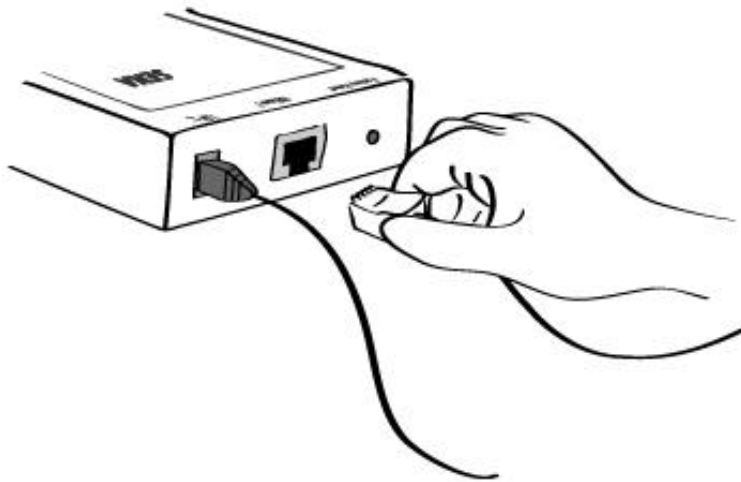

2-3. LS100

2.2.3

LS100

LS100

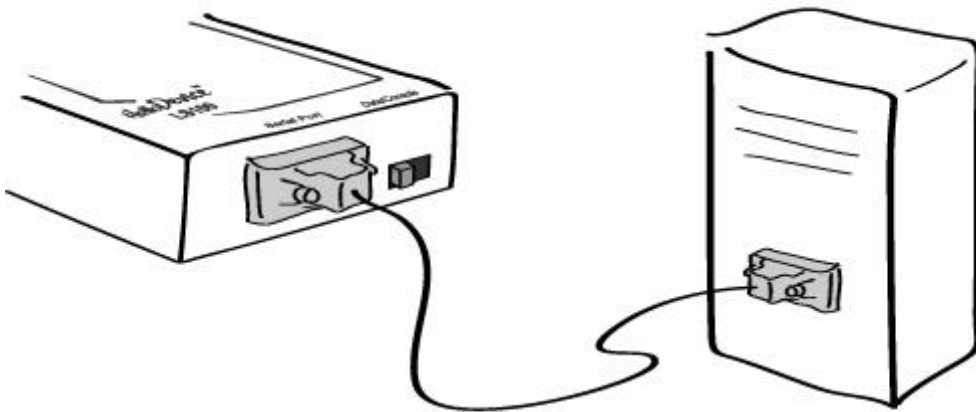

2 - 4. LS100

## 2.3

가 가  
- :  
/ ( ) LS100  
. LS100 /  
- :  
TCP/IP LS100 ( 23) telnet  
.  
LS100

### 2.3.1

- 1) LS100

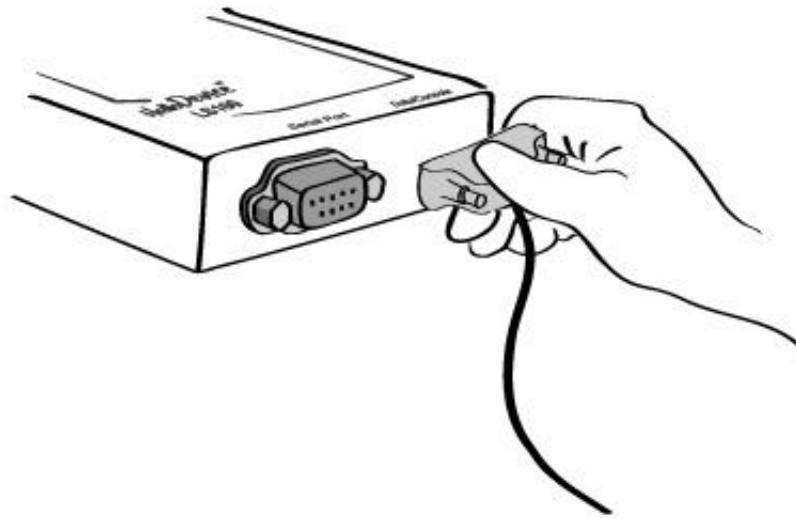

2-5. LS100

- 2)
- 3) /

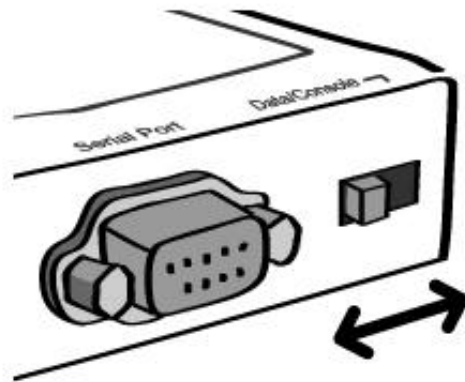

2 - 6. LS100 /

4) (HyperTerminal)

**9600 Baud rate, Data bits 8, Parity None, Stop bits 1, No flow control**

5) [ENTER]

6) LS100

**admin**

7) 가 LS100 2-7

```

login: admin
password: *****
Type 'help' to get command usages
> help
set group par1 [par2 ...] + <CR>
- group = 'ip','host','serial' or 'admin'
- par1 ... = configuration parameters. Use * to keep a parameter's value
get [group] + <CR>
- group = 'ip','host','serial','admin' or 'status'
- If group is specified, shows settings of the group.
- If group is omitted, shows settings of all groups.
factorydefault [option] + <CR>
- if option is omitted, all parameters are set with factory default values.
- if option='-ip',
  all parameters except IP settings are set with factory default values.
help [group] + <CR>
- If group is omitted, shows this screen.
- If group is specified, shows 'set' command usage of the group.
save + <CR>
- Save changes
exit + <CR>
- Exit without rebooting the device
reboot + <CR>
- Exit and reboot the device
>

```

2 - 7. LS100

'set', 'get' 'save'  
'exit' 'reboot'

'help'

2.4

### 2.3.2

LS100

telnet

LS100

가

LS100 IP

telnet

TCP

23

LS100

1) TeraTerm-Pro

telnet

Target IP

LS100

23

telnet 192.168.1.254

telnet

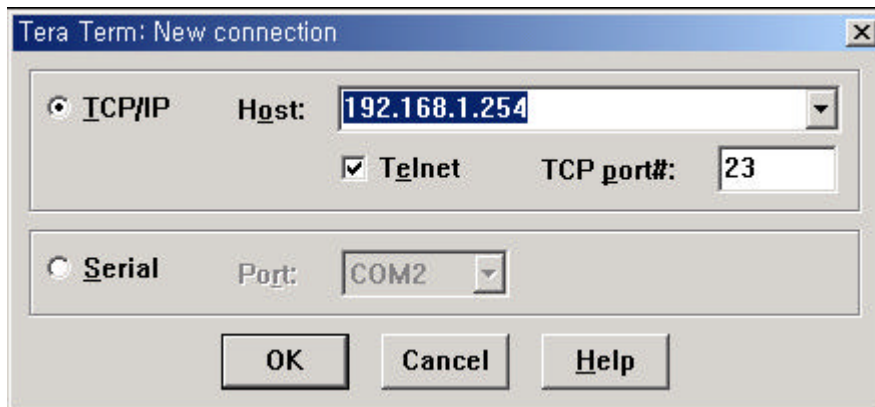

2 - 8 Telnet

2) LS100

admin

3) LS100

4)



## 2.4

LS100

가

2-2 LS100

### 2 - 2 LS100

set group par1 [par2 ...] + <CR>	<ul style="list-style-type: none"> <li>- group = 'ip', 'host', 'serial' 'admin'</li> <li>- par1 ... = *</li> </ul>	<p>"OK" + &lt;CR&gt; + &lt;LF&gt;</p> <p>If error</p> <p>"ERROR" + &lt;CR&gt; + &lt;LF&gt;</p>
get [group] + <CR>	<ul style="list-style-type: none"> <li>- group = 'ip', 'host', 'serial', 'admin' 'status'</li> <li>-</li> <li>-</li> </ul>	
help [group] + <CR>	<ul style="list-style-type: none"> <li>-</li> <li>- ..</li> <li>- , 'set'</li> </ul>	
factorydefault [option] + <CR>	<ul style="list-style-type: none"> <li>- , 가</li> <li>- if option='-ip' IP 가</li> </ul>	<p>"OK" + &lt;CR&gt; + &lt;LF&gt;</p> <p>가</p> <p>"ERROR" + &lt;CR&gt; + &lt;LF&gt;</p>
save + <CR>		<p>"OK" + &lt;CR&gt; + &lt;LF&gt;</p> <p>가</p> <p>"ERROR" + &lt;CR&gt; + &lt;LF&gt;</p>
exit + <CR>	) (	<p>"OK" + &lt;CR&gt; + &lt;LF&gt;</p> <p>가</p> <p>"ERROR" + &lt;CR&gt; + &lt;LF&gt;</p>
reboot + <CR>		None

## 2.4.1 'set'

'set' LS100 'set'

**set group par1 [par2 ...] + <CR>**

**where,**

**group = 'ip','host','serial' or 'admin'**

**par1 par2 ... = configuration parameters. Use \* to keep a parameter's value**

'group' , IP 2-  
9 set

```
> set ip static 192.168.1.100 255.255.255.0 192.168.1.1
OK
>
```

2 - 9 IP

'static' LS100 'ip' 가 IP  
'192.168.1.100' static IP IP  
IP

```
> set ip static * 255.255.0.0
OK
>
```

2 - 10

'set' 'help group' 'set'  
, IP 'set' , 'help ip' + <CR>  
2-11 IP 'set'

```
> help ip
set ip ipmode par1 par2 ...
- ipmode: static=Static IP / dhcp=DHCP / pppoe=PPPoE
- parameters:
if ipmode = static,
    par1 = IP address,
    par2 = subnet mask,
    par3 = gateway
if ipmode = dhcp,
    no parameters required
if ipmode = pppoe,
    par1 = PPPoE username,
    par2 = PPPoE password
>
```

2 - 11

:  
'save' 'reboot' . 2.4.5 ~ 2.4.7

## 2.4.2 'get'

'get' LS100 . 'get'

**get [group] + <CR>**

**where,**

**group = 'ip', 'host', 'serial', 'admin' or 'status'**

**- If group is specified, shows settings of the group.**

**- If group is omitted, shows settings of all groups.**

'set' 가 , IP  
2-12 get .

```
> get ip
IP_mode: static
IP_address: 192.168.1.100
Subnet_mask: 255.255.255.0
Gateway: 192.168.1.1
>
```

2 - 12 IP

'status' 'set' 가 . 'get status'

```
> get status
Serial_no.: LS100-0207_test
MAC_address: 00-01-95-77-88-99
F/W_REV.: V1.2.0
Current_IP: 192.168.0.125
>
```

2 - 13

, get 2-14 .

```
> get
--- Status ---
Serial_no.: LS100-0207_test
MAC_address: 00-01-95-77-88-99
F/W_REV.: V1.2.0
Current_IP: 192.168.0.125
--- Admin ---
Username: admin
Password: admin
Devicename: LS100 Device
--- IP ---
IP_mode: dhcp
```

```

--- Host ---
Host_mode: tcps
Local_port: 6001
Inactivity_timeout(sec): 300
--- Serial ---
Baudrate: 9600
Data_bits: 8_bits
Parity: None
Stop_bits: 1_bit
Flow_control: None
DTR_option: Always_high
DSR_option: None
Interchar_timeout(ms): 50
>

```

2 - 14

### 2.4.3 'help'

'help'

**help [group] + <CR>**

**where,**

***if group is omitted, overall help screen will be displayed***

***if group is specified, 'set' command usage of specified group will be displayed.***

2-15

2-16 'ip'

```

> help
set group par1 [par2 ...] + <CR>
- group = 'ip','host','serial' or 'admin'
- par1 ... = configuration parameters. Use * to keep a parameter's value
get [group] + <CR>
- group = 'ip','host','serial','admin' or 'status'
- If group is specified, shows settings of the group.
- If group is omitted, shows settings of all groups.
help [group] + <CR>
- If group is omitted, shows this screen.
- If group is specified, shows 'set' command usage of the group.
factorydefault [option] + <CR>
- if option is omitted, all parameters are set with factory default values.
- if option='-ip',
    all parameters except IP settings are set with factory default values.
save + <CR>
- Save changes
exit + <CR>
- Exit without rebooting the device
reboot + <CR>
- Exit and reboot the device

```

2 - 15

```

> help ip
set ip ipmode par1 par2 ...
- ipmode: static=Static IP / dhcp=DHCP / pppoe=PPPoE
- parameters:
if ipmode = static,
    par1 = IP address,
    par2 = subnet mask,
    par3 = gateway
if ipmode = dhcp,
    no parameters required
if ipmode = pppoe,
    par1 = PPPoE username,
    par2 = PPPoE password

```

2 - 16 'ip'

#### 2.4.4 'factorydefault'

'factorydefault'

'factorydefault'

**factorydefault [option] + <CR>**

**where,**

**- if option is omitted, all parameters are set with factory default values.**

**- if option='-ip', all parameters except IP settings are set with factory default values.**

```

'save'                                     'factorydefault'
'save' 'reboot'

```

```

> factorydefault (or factorydefault -ip)
OK
> save
OK
> reboot

```

2 - 17

## 2.4.5 'save'

'save'

. 'save'

**save + <CR>**

'reboot'

LS100

## 2.4.6 'exit'

'exit'

LS100

. 'exit'

**exit + <CR>**

## 2.4.7 'reboot'

'reboot'

LS100

. LS100

가

. 'reboot'

**reboot + <CR>**

### 3: IP

LS100

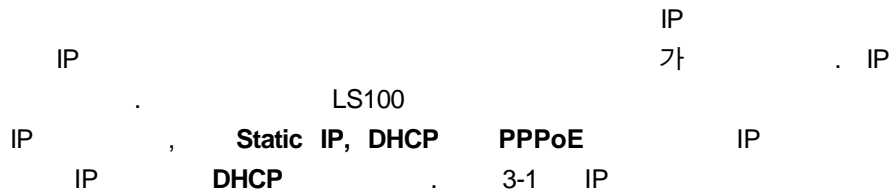

3 - 1 IP

<b>Static IP</b>	IP address
	Subnet mask
	Default gateway
<b>DHCP</b>	No parameters required
<b>PPPoE</b>	PPPoE username
	PPPoE password

IP 'set'

**set ip ipmode par1 par2 ...**

**where,**

**ipmode:** 'static' for Static IP / 'dhcp' for DHCP / 'pppoe' for PPPoE

**parameters:**

**if ipmode = static,**

**par1 = IP address, par2 = subnet mask, par3 = gateway**

**if ipmode = dhcp,**

**no parameters required**

**if ipmode = pppoe,**

**par1 = PPPoE username, par2 = PPPoE password**

### 3.1 Static IP

#### 3.1.1

Static IP LS100 IP , IP

IP . IP IP

가 , LS100 LAN TCP/IP 가  
가 LS100  
LS100  
가  
ISP LS100  
IP

#### 3.1.2 Static IP

LS100 IP set .

**set ip static ip\_address subnet\_mask default\_gateway + <CR>**

**where,**

**ip\_address = IP address of the LS100**

**subnet\_mask = Subnet mask**

**default\_gateway = Default gateway IP address**

3-1 IP . 'save' 'reboot'

```
> set ip static 192.168.1.10 255.255.255.0 192.168.1.1  
OK
```

3 - 1. Static IP IP



## 3.2 DHCP

### 3.2.1

(DHCP) 가 IP  
. DHCP 가 IP  
IP Static IP  
IP 가 DHCP IP , , IP , DNS  
" (lease)" . DHCP IP 가 DHCP  
LS100 IP DHCP  
DHCP 가 IP , , DNS  
. LS100 DHCP 가  
LS100 IP . LS100 DHCP  
IP . LS100 DHCP  
DHCP 가 IP IP  
DHCP , LS100 IP ..  
가 LS100 IP IP DHCP . DHCP  
IP LS100 MAC 가  
MAC=00:01:95:04:0c:a1

### 3.2.2 DHCP

LS100 DHCP

3-2

IP

DHCP

```
> set ip dhcp
OK
>
```

3 - 2. DHCP

### 3.3 PPPoE

#### 3.3.1

PPPoE LAN 가 (Customer Premises Equipment) . (가 (Customer Premises Equipment) .) PPPoE

가 ADSL, .

PPPoE ADSL .

LS100 PPPoE PPPoE ADSL PPPoE 가

. LS100 PPPoE ADSL

. PPPoE .

IP 가 PPPoE LS100 PPPoE PPPoE

. IP , , DNS

가 LS100 가

가 LS100 PPPoE .

#### 3.3.2 PPPoE

LS100 PPPoE 3-3 ADSL PPPoE

```
> set ip pppoe pppoeuser pppoepassword
OK
>
```

#### 3 - 3. PPPoE

4.

LS100  
 가 . TCP  
 . 4-1

TCP

4 - 1. LS100 TCP/IP

TCP	LS100 TCP . TCP . 가 . LS100 TCP , 가 TCP . TCP 가
TCP	LS100 TCP . 가 LS100 TCP . TCP LS100 LS100 가 . TCP
TCP /	LS100 TCP . 가 . LS100 .

4-2

4 - 2

TCP Server	Listening TCP port
	Inactivity timeout (sec)
TCP Client	Destination IP
	Destination TCP Port
	Cyclic connection Interval
	Inactivity timeout (sec)
TCP Server/Client	Listening TCP port
	Destination IP
	Destination TCP Port
	Cyclic connection Interval
	Inactivity timeout (sec)

'set'

**set host hostmode par1 par2 ...**

**where,**

**hostmode: tcps=TCP server / tcpc=TCP client / tcpsc=TCP server & client**

**parameters:**

**if hostmode = TCP server (tcps),**

**par1 = listening TCP port,**

**par2 = inactivity timeout (sec)**

**if hostmode = TCP client (tcpc),**

**par1 = destination IP address,**

**par2 = destination TCP port,**

**par3 = cyclic connection interval (min),**

**par4 = inactivity timeout (sec)**

**if hostmode = TCP server & client (tcpsc),**

**par1 = listening TCP port,**

**par2 = destination IP address,**

**par3 = destination TCP port,**

**par4 = cyclic connection interval (min),**

**par5 = inactivity timeout (sec)**

**\* set cyclic connection interval to 0 not to use cyclic connection**

**\* set inactivity timeout to 0 for unlimited timeout**

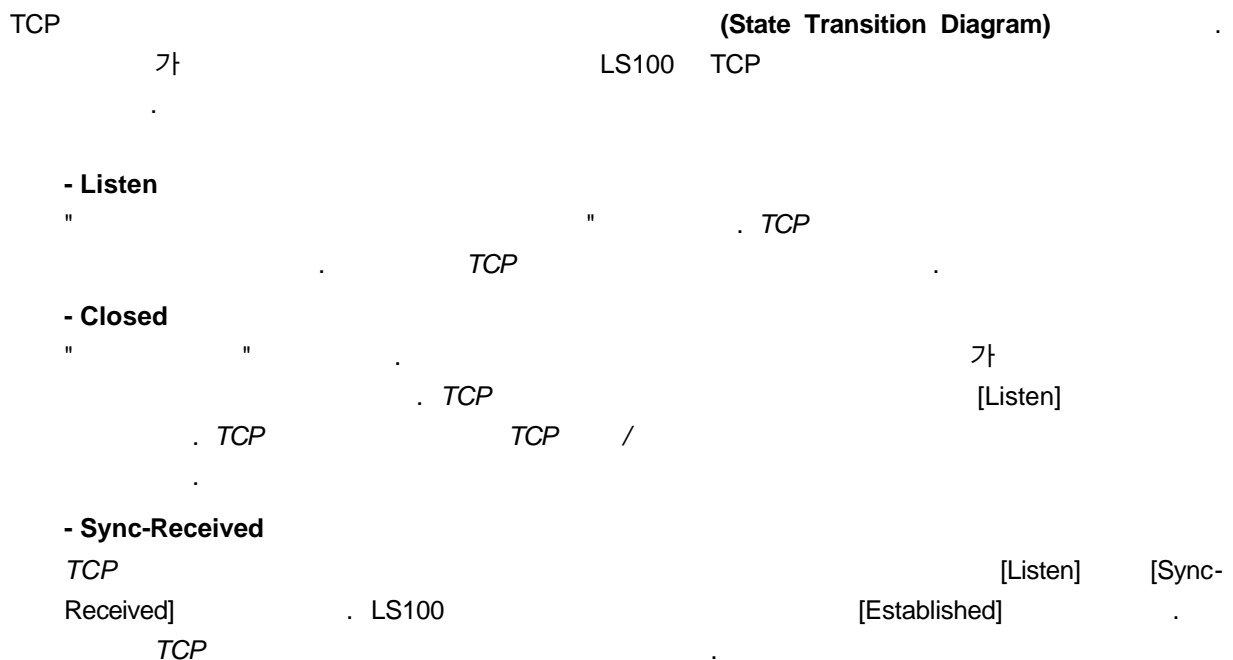

**- Sync-Sent**

LS100

가

[Closed]

[Sync-Sent]

TCP

**- Established**

" "

[Established]

가

**- Data**

[Established]

가

TCP

[Data]

[Data]

RFC 793 [Transmission Control Protocol]

[Established]

## 4.1 TCP

### 4.1.1



1)

[Listen] --> [Sync-Received] --> [Established] --> [Data] --> [Closed] --> [Listen]

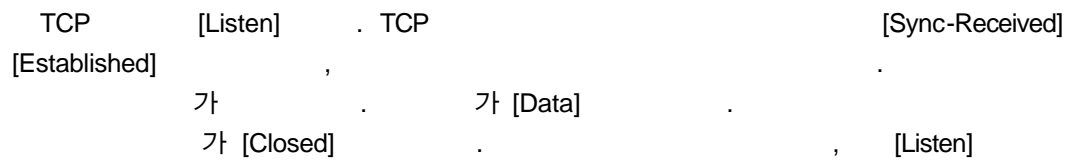

2)

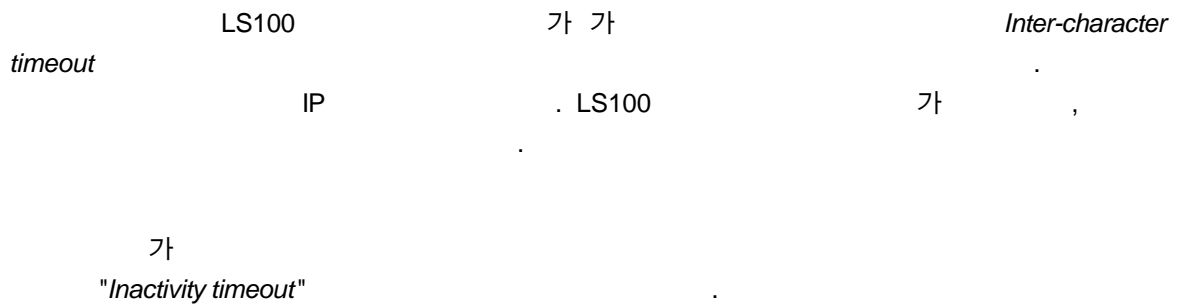

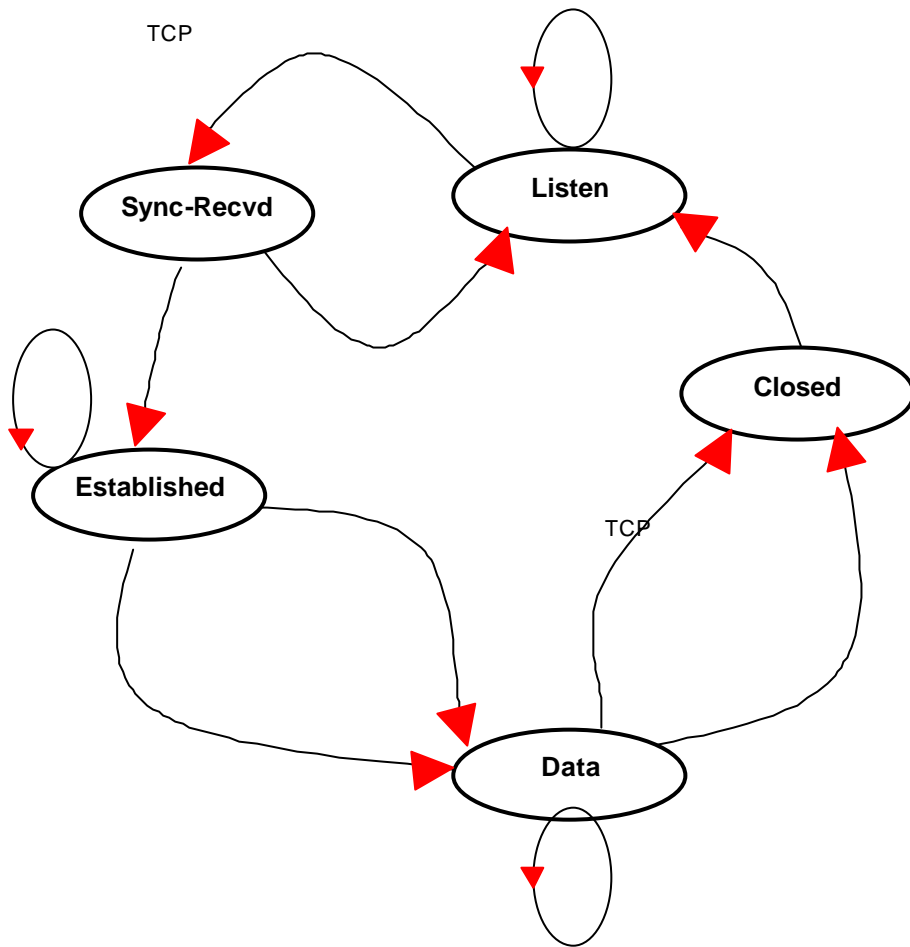

4 - 1. TCP

### 4.1.2 TCP

LS100 TCP 'set'

**set host tcps listening\_TCP\_port inactivity\_timeout + <CR>**

*where,*

***listening\_TCP\_port: Listening TCP port***

***Inactivity\_timeout: Inactivity timeout in seconds.***

**Listening TCP port** 가 TCP TCP  
Listening TCP Port . LS100  
( D. ) TCP  
2  
**Inactivity timeout** TCP host LS100 TCP  
Closed Listen . *Inactivity timeout*  
가 가 TCP  
*Inactivity timeout* 0 , TCP  
*Inactivity timeout* LS100 "keep alive" LS100  
가  
LS100 TCP  
:  
*Inter-character timeout*

#### 4-2 TCP

```
> set host tcps 6001 300  
OK  
>
```

Figure 4 - 2. TCP



## 4.2 TCP

### 4.2.1

TCP LS100 TCP , TCP [Closed] .  
 TCP PC TCP

1)

[Closed] --> [Sync-Sent] --> [Established] --> [Data] --> [Closed]  
 TCP [Closed] . 가 LS100  
 [Sync-Sent] ,  
 가 [Established] 가  
 [Data] .  
 [Closed] .

2)

가 LS100 LS100  
 . TCP 가 가  
*Inter-character timeout*  
 IP . LS100 ,  
 가 .  
 가  
*"Inactivity timeout"*  
 가 .  
 TCP TCP .  
*Cyclic Connection* LS100 가  
 가  
 가  
 LS100 LS100 가  
 LS100 가 가  
 가 4-3 TCP 가

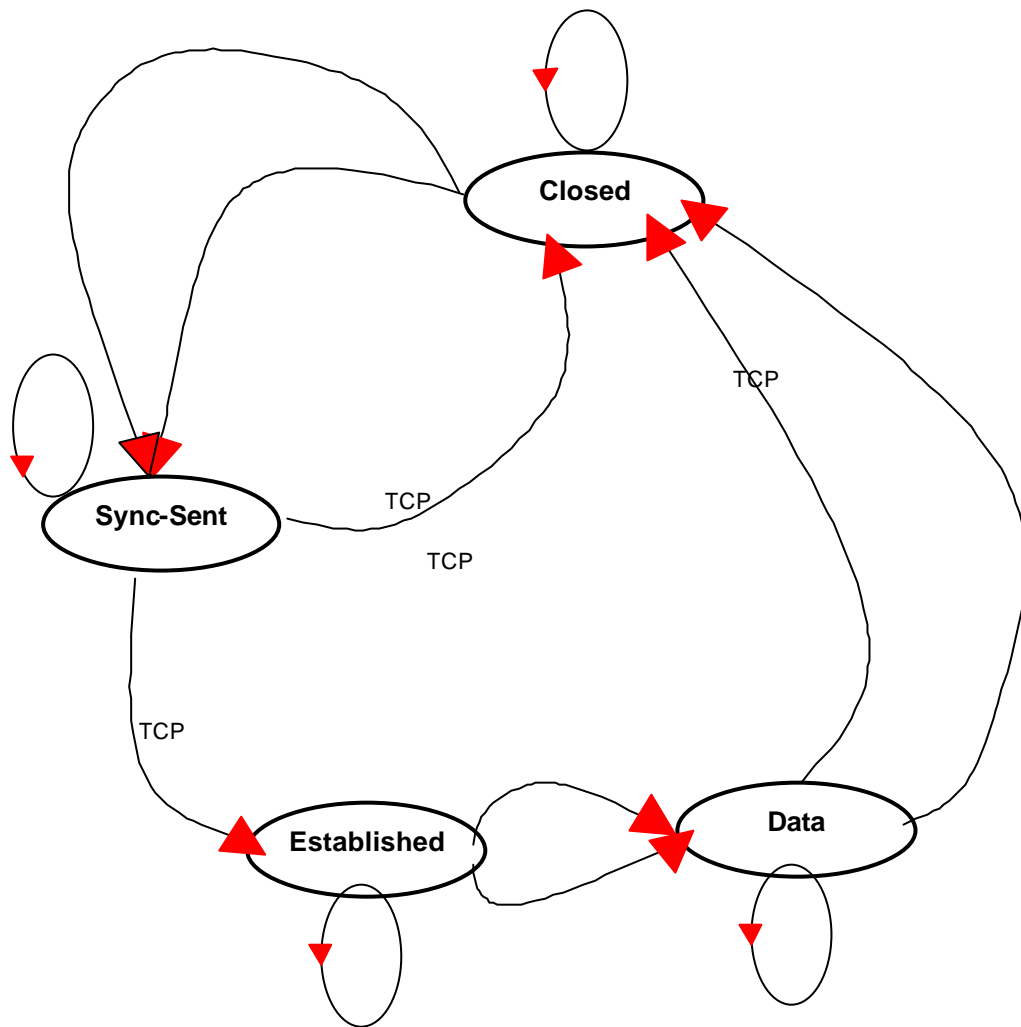

4 - 3. TCP

## 4.2.2 TCP

LS100 TCP set

**set host tcpc dest\_ip dest\_port cyclic\_connection\_interval inactivity\_timeout + <CR>**

**where,**

**dest\_ip = destination IP address**

**dest\_port = destination TCP port**

**cyclic\_connection\_interval = cyclic connection interval in minutes**

**inactivity\_timeout = inactivity timeout in seconds.**

```
IP          TCP          LS100  TCP client
.IP        (          ) TCP
          LS100
          . 0
          . 0
```

**Inactivity timeout TCP**

4-4 TCP

```
> set host tcpc 192.168.1.1 6001 10 300
OK
>
```

4 - 4 TCP



2)

TCP

TCP

LS100

TCP

TCP

TCP

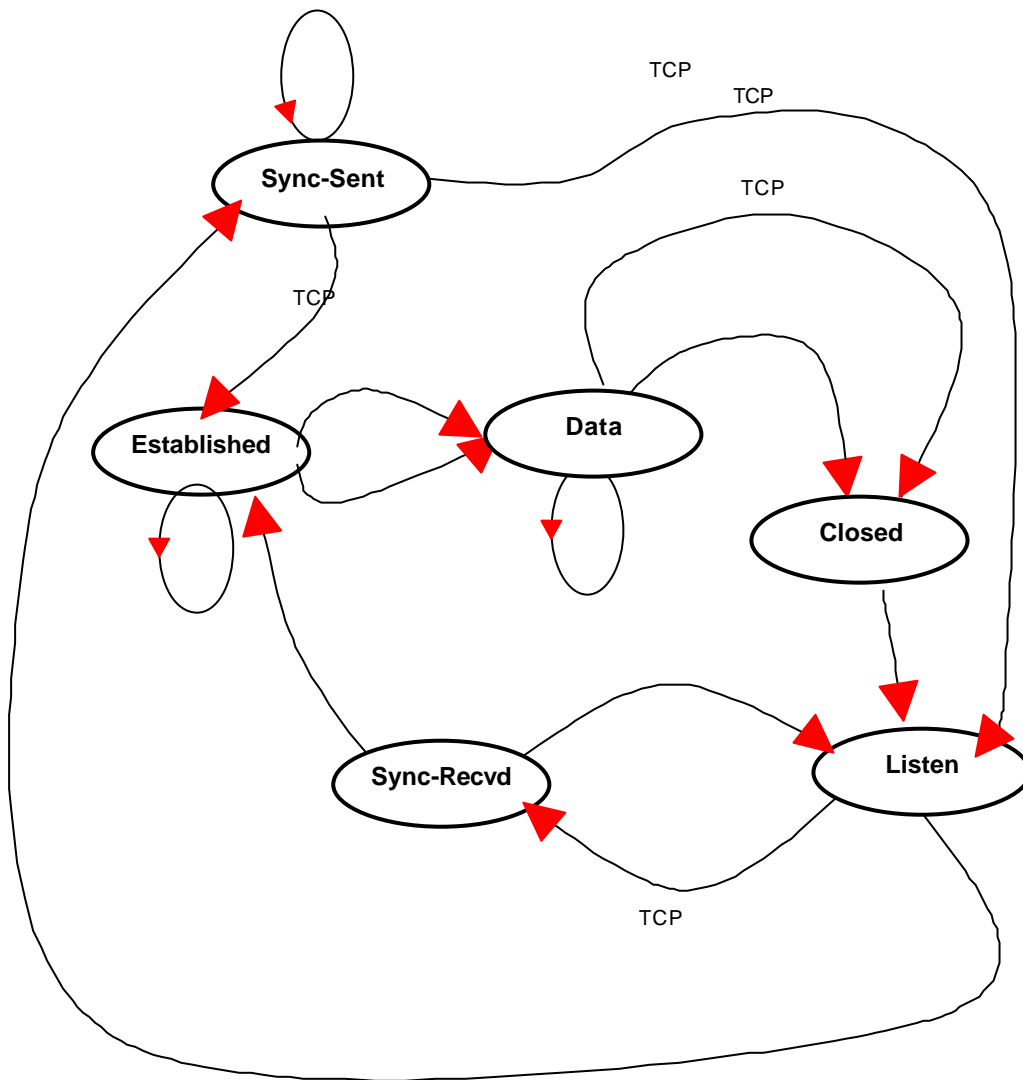

4 - 5. TCP /

### 4.3.2 TCP /

LS100 TCP / 'set'

**set host tcpssc listening\_port dest\_ip dest\_port cyclic\_connection\_interval inactivity\_timeout  
where,**

***listening\_port = listening TCP port***

***dest\_ip = destination IP address***

***dest\_port = destination TCP port***

***cyclic\_connection\_interval = cyclic connection interval in minutes***

***inactivity\_timeout = inactivity timeout in seconds.***

TCP /

TCP

TCP

4-6 TCP /

```
> set host tcpssc 6001 192.168.1.100 7001 10 300  
OK  
>
```

4 - 6 TCP /

5:

LS100

5-1

5 - 1.

	Values
Baud rate	1200, 2400, 4800, 9600, 19200, 38400, 57600, or 115200
Data bits	7 bits or 8 bits
Parity	None, Even or Odd
Stop bits	1 bit or 2 bits
Flow control	None, Hardware (RTS/CTS)
DTR option	Always HIGH, Always LOW, Show TCP connection
DSR option	None, Accept TCP connection only by HIGH, Open/Close TCP connection
Inter-character timeout	Inter-character timeout value in milliseconds

'set'

**set serial baudrate data\_bits parity stop\_bits flow\_control dtr\_option dsr\_option interchar\_timeout(ms)**

**where,**

**baudrate: 1200, 2400, 4800, 9600, 19200, 38400, 57600, or 115200**

**data\_bits: 7=7-bits / 8=8-bits**

**parity: n=none / e=even / o=odd**

**stop\_bits: 1=1-bit / 2=2-bits**

**flow\_control: n=none / h=hardware**

**dtr\_option: h=always high / l=always low / s=show tcp connection**

**dsr\_option: n=none / a=accept only by high / o=open,close TCP connection**

**interchar\_timeout: inter-character timeout value in milliseconds**

```

, , , 9600 bps, 8 , , 1
. LS100 가 . LS100 7
, , 1 LS100 2 . 8
, ( ) , 2 LS100 1
.
None . LS100 RTS/CTS

```

DTR/DSR TCP  
 . DTR , DSR LS100  
**DTR option** *always high, always low show TCP connection* 가  
 . DTR *show TCP connection* DTR TCP  
 HIGH  
**DSR option** *none, allow TCP connection only by high open/close TCP connection* 가  
 . *Allow TCP connection only by HIGH* 가 TCP  
 TCP DSR 가  
 HIGH . *Open/close TCP connection* 가 TCP  
 . DSR *Open/close TCP connection* ,  
 DSR HIGH LS100 , LOW

**Inter-character timeout** LS100  
 가 LS100  
 LS100 가 가 , *Inter-character timeout*  
 TCP/IP  
 Inter-character timeout baud rate  
 , 가 1200 bps, 8 Data bits, 1 stop bit no  
 parity 가 , 10  
 $10 ( ) / 1200 ( / ) * 1000 ( / ) = 8.3$   
*Inter-character timeout* 8.3 ms . *Inter-character timeout*  
 10 ms  
*Inter-character timeout* ,  
 LS100 . LS100 1400

5-1 9600 bps, 7 , , 2 , , DTR TCP  
 , DSR , 10 ms inter-character time-out

```
> set serial 9600 7 e 2 h s n 10
OK
>
```



6:

set

**set admin username password devicename**

**username: login username**

**password: login password**

**devicename: device name**

7-1

```
> set admin adminuser adminpassword LS100_test1
OK
>
```

7 - 1

A:

## A.1 Pin Outs

LS100 AT&T258

A-1

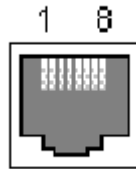

A - 1. RJ45

A - 1. RJ45

1	Tx+	
2	Tx-	
3	Rx+	
4	NC	
5	NC	
6	Rx-	
7	NC	
8	NC	

## A.2

LS100 DB9

## Pin Outs

A-2

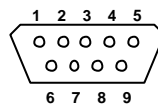

A - 2. DB - 9

A - 2. DB - 9

	RS232
1	-
2	Rx
3	Tx
4	DTR
5	GND
6	DSR
7	RTS
8	CTS
9	-

A.3

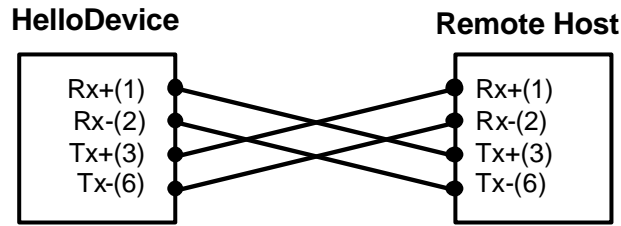

A - 3.

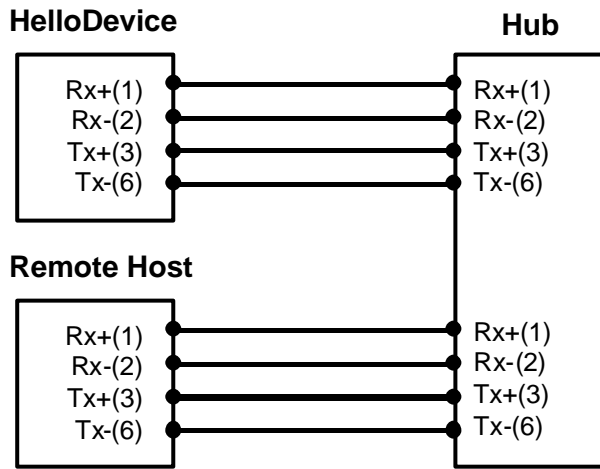

A - 4.

A.4

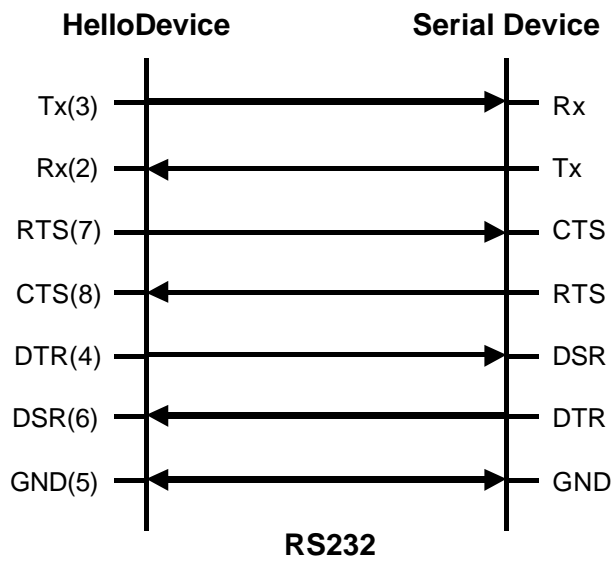

A - 5. RS232

B:

가 , / 가 .  
0 1023 1024 49151 .  
49152 65535 .  
IANA가 , 가  
가 B - 1  
IANA

URL <http://www.iana.org/assignments/port-numbers>

B - 1.

		TCP/UDP
21	FTP (File Transfer Protocol)	TCP
22	SSH (Secure SHell)	TCP
23	Telnet	TCP
25	SMTP (Simple Mail Transfer Protocol)	TCP
37	Time	TCP, UDP
39	RLP (Resource Location Protocol)	UDP
49	TACACS, TACACS+	UDP
53	DNS	UDP
67	BOOTP server	UDP
68	BOOTP client	UDP
69	TFTP	UDP
70	Gopher	TCP
79	Finger	TCP
80	HTTP	TCP
110	POP3	TCP
119	NNTP (Network News Transfer Protocol)	TCP
161/162	SNMP	UDP

C:

C.1 /LED

Power LED가		
Link LED가		
		가 LS100
ACT LED가	IP	IP

C.2

		) (
		. 9600 bps, 8 Data bits, No parity, 1 stop bit, Hardware flow control
	/ 가	/ 가
	IP DHCP IP가	IP 가 DHCP IP가 DHCP 20 . IP static IP
	가	admin

### C.3

Telnet LS100	LS100 가 IP	LS100 IP
		telnet
	가	admin

### C.4 IP

LS100 IP		IP
		HelloDeviceManager LS100
HelloDeviceManager LS100	LS100 가 IP	LS100 IP
	HelloDeviceManager LS100	LS100 PC HelloDeviceManager

### C.5 DHCP

IP	DHCP 가	DHCP 가
LS100 IP 가	DHCP 가	DHCP 가

## C.6 TCP

LS100	IP	IP
	LS100 가 TCP 가	LS100 / TCP TCP
	LS100 IP TCP 가	LS100 IP TCP
	DSR DSR HIGH	DSR LS100 DSR HIGH
	TCP	TCP

## C.7

TCP/IP 가	Inter-character timeout 가	Inter-character tim eout
LS100		LS100
가		