

HelloDevice Lite Series

LS110

User Guide

Version 1.0.0

2007-05-07

Copyright

Copyright 2002-2007, Sena Technologies, Inc. All rights reserved.

Sena Technologies reserves the right to make changes and improvements to its product without providing notice.

Trademark

HelloDevice™ is a trademark of Sena Technologies, Inc.

Windows® is a registered trademark of Microsoft Corporation.

Ethernet® is a registered trademark of XEROX Corporation.

Notice to Users

Proper back-up systems and necessary safety devices should be utilized to protect against injury, death or property damage due to system failure. Such protection is the responsibility of the user.

This device is not approved for use as a life-support or medical system.

Any changes or modifications made to this device without the explicit approval or consent of Sena Technologies will void Sena Technologies of any liability or responsibility of injury or loss caused by any malfunction.

Technical Support

Sena Technologies, Inc.

210 Yangjae-dong, Seocho-gu

Seoul 137-130, Korea

Tel: (+82-2) 573-5422

Fax: (+82-2) 573-7710

E-Mail: support@sena.com

Website: <http://www.sena.com>

Revision history

Revision	Date	Name	Description
V1.0.0	2007-05-07	W.J. Kim	Initial release

Contents

1. Introduction	7
1.1 Overview	7
1.2 Package Check List	7
1.3 Product Specification	8
1.4 Terminologies and Acronyms	9
2. Getting Started	11
2.1 Panel Layout	11
2.2 Connecting the Hardware	12
2.2.1 Connecting the Power	12
2.2.2 Connecting to the Network	13
2.2.3 Connecting to the Device.....	14
2.3. Accessing Console Port	14
2.3.1 Using Serial Console	15
2.3.2 Using Remote Console.....	16
3. IP Address Configuration	18
3.1 Static IP	18
3.1.1 Overview.....	18
3.1.2 Static IP Configuration	18
3.1.3 IP address	19
3.1.4 Subnet mask	20
3.1.5 Default gateway	21
3.2 DHCP	21
3.2.1 Overview.....	21
3.2.2 DHCP Configuration	22
3.3 DNS	22
3.3.1 Primary DNS Configuration	23
3.3.2 Secondary DNS Configuration.....	23
4. Host Mode Configuration	24
4.1 Host mode.....	24
4.1.1 Overview.....	24
4.1.2 TCP server mode operations.....	27
4.1.3 TCP client mode operations.....	29
4.1.4 TCP server/client mode operations	33
4.1.5 UDP tunneling mode operations	35
4.1.6 UDP server mode operations.....	35
4.1.7 Modem emulation mode operations.....	36

4.1.8 Telnet Server mode	39
4.2 Serial Port configuration.....	40
4.2.1 Baud rate	40
4.2.2 Data bits, Stop bit(s), Parity	41
4.2.3 Flow control.....	42
4.3 Options.....	43
4.3.1 DTR/DSR behavior.....	43
4.3.2 Inactivity timeout.....	44
4.3.3 Inter-character timeout	45
4.3.4 IP Filtering.....	46
5. System information	49
6. System administration	50
6.1 Device name	50
6.2 Username	51
6.3 Password	51
6.4 Factory reset	52
6.5 Factory reset without IP settings	52
6.6 Firmware upgrade	53
6.7 Ping.....	54
6.8 User connection status	55
6.9 Telnet configuration enable/disable	56
7. Other Menus	57
7.1 Save changes.....	57
7.2 Exit without reboot	57
7.3 Save and reboot	58
Appendix A: Connections	59
A.1 Ethernet Pin outs.....	59
A.2 Serial Port Pin Outs	59
A.3 Ethernet Wiring Diagram	60
A.4 Serial Wiring Diagram.....	60
Appendix B: Well-known Port Numbers	61
Appendix C: Troubleshooting	62
C.1 Power/LED Status Troubleshooting	62
C.2 Serial Console Troubleshooting	62
C.3 Remote Console Troubleshooting.....	63
C.4 IP Address Troubleshooting.....	63
C.5 DHCP Troubleshooting.....	63
C.6 TCP Server Mode Operation Troubleshooting.....	64

C.7 Serial Communication Troubleshooting	64
Appendix D: Warranty	65
D.1 GENERAL WARRANTY POLICY	65
D.2 LIMITATION OF LIABILITY.....	65
D.3 HARDWARE PRODUCT WARRANTY DETAILS	66
D.4 SOFTWARE PRODUCT WARRANTY DETAILS.....	66
D.5 THIRD-PARTY SOFTWARE PRODUCT WARRANTY DETAILS	66

1. Introduction

1.1 Overview

The LS110 allows you to network-enable a variety of serial devices that were not originally designed to be networked. This capability brings the advantages of remote management and data accessibility to thousands of serial devices over the network.

The LS110 is a cost effective one port serial-Ethernet communication device. The LS110 supports RS232 serial communication allowing virtually any asynchronous serial device to be accessed over a network.

As for Internet connectivity, the LS110 supports open network protocols such as TCP/IP allowing serial devices to be accessed over broadband network or conventional LAN (Local Area Network) environment.

The LS110 provides a management console by using Telnet and serial console port which is all password protected. The LS110 also provides an additional management function by using the HelloDevice Manager Software Utility.

The LS110 was designed to accommodate the unique requirements of the Retail POS, Security, Automation and Medical marketplaces.

Parts of this manual assume that the user has some knowledge on the concepts of the Internetworking protocols and serial communications. If you are not familiar with these concepts, please refer to the standards or the respective documentation on each subject.

1.2 Package Check List

- LS110 external box
- 110V or 230V Power supply adapter
- Serial console/data cable
- A hardcopy of Quick Start Guide
- CD-ROM including the Serial/IP, HelloDevice Manager and User Guide

1.3 Product Specification

Table 1-1 Product Specification Table

Serial Interface	One male DB9 serial port for data communication/serial console
	Serial speeds 1200bps to 115200bps
	Hardware Flow Control
	Signals: Rx, Tx, RTS, CTS, DTR, DSR, DCD, GND (RS232 Only)
Network Interfaces	10 Base-T Ethernet with RJ45 Ethernet connector Supports static and dynamic IP address
Protocols	ARP, IP/ICMP, TCP, UDP, Telnet, DNS, DHCP Serial Port Access Protocol : TCP, UDP, RFC-2217
Security	User ID & Password
Management	Console Port Telnet HelloDevice Manager software O/S support : Windows 98/ME/NT/2000/XP
Firmware	Upgrade using Console, Telnet
Diagnostic LED	Power Ready 10 Base-T Link, Act Serial Rx/Tx for data serial port
	Supply voltage 7.5V ~ 15V DC
Power	Supply current 0.30A @ 9VDC
	Operating temperature: 0 ~ 50 °C Storage temperature: -20 ~ 66 °C Humidity : 90% Non-condensing
Physical properties	Dimension 100 mm L (3.9 in.) 72 mm W (2.8 in.) 25 mm H (1 in.)
	Weight 240g
Approvals	FCC(A), CE(A), MIC
Warranty	5-year limited warranty

1.4 Terminologies and Acronyms

The Internetworking related terminologies used frequently in this manual are defined clearly to help you better understand the LS110.

MAC address

On a local area network or other network, the MAC (Media Access Control) address is the computer's unique hardware number. (On an Ethernet LAN, it's the same as your Ethernet address.)

It is a unique 12-digit hardware number, which is composed of 6-digit OUI (Organization Unique Identifier) number and 6-digit hardware identifier number. The LS110 has the MAC address of 00-01-95-xx-xx-xx, which is labeled on the bottom side of the external box.

Host

A user's computer connected to the network

In Internet protocol specifications, the term "host" means any computer that has full two-way access to other computers on the Internet. A host has a specific "local or host number" that, together with the network number, forms its unique IP address.

Session

A series of interactions between two communication end points that occur during the span of a single connection

Typically, one end point requests a connection with another specified end point and if that end point replies agreeing to the connection, the end points take turns exchanging commands and data ("talking to each other"). The session begins when the connection is established at both ends and terminates when the connection is ended.

Client/Server

Client/server describes the relationship between two computer programs in which one program, the client, makes a service request from another program, the server, which fulfills the request.

A server is a computer program that provides services to other computer programs in the same or other computers, whereas a client is the requesting program or user in a client/server relationship. For example, the user of a Web browser is effectively making client requests for pages from servers all over the Web. The browser itself is a client in its relationship with the computer that is getting and returning the requested HTML file. The computer handling the request and sending back the HTML file is a server.

Table 1-2 Acronym Table

ISP	Internet Service Provider
PC	Personal Computer
NIC	Network Interface Card
MAC	Media Access Control
LAN	Local Area Network
UTP	Unshielded Twisted Pair
ADSL	Asymmetric Digital Subscriber Line
ARP	Address Resolution Protocol
IP	Internet Protocol
ICMP	Internet Control Message Protocol
UDP	User Datagram Protocol
TCP	Transmission Control Protocol
DHCP	Dynamic Host Configuration Protocol
SMTP	Simple Mail Transfer Protocol
FTP	File Transfer Protocol
HTTP	HyperText Transfer Protocol
DNS	Domain Name Service
UART	Universal Asynchronous Receiver/Transmitter
Bps	Bits per second (baud rate)
DCE	Data Communications Equipment
DTE	Data Terminal Equipment
CTS	Clear to Send
DSR	Data Set Ready
DTR	Data Terminal Ready
RTS	Request To Send

2. Getting Started

This chapter describes how to set up and configure the LS110.

- 2.1 *Panel Layout* explains the panel layout and LED indicators.
- 2.2 *Connecting the Hardware* describes how to connect the power, the network, and the serial device to the LS110.
- 2.3 *Accessing Console Port* describes how to access the console port using a serial console at a local site or telnet console at a remote site.
- 2.4 *Command Usages* described how to use command set of the LS110 to configure and view parameter values and status.

Following items are required to get started.

- One DC power adapter (included in the package).
- One serial console cable for configuration (included in the package).
- One RS-232 serial cable for connecting the RS-232 serial device.
- One PC with Network Interface Card (hereafter, NIC) and/or one RS232 serial port.
- Terminal emulation program running on the PC
- One Ethernet cable

2.1 Panel Layout

The LS110 has five LED indicator lamps for status display. Two lamps on the upper side indicate status of the 10 Base-T Ethernet Link and Act. Next lamp indicates status of receive and transmit of the serial port. Next two lamps indicate the system running status and the system power-on status. Table 2-1 describes function of each LED indicator lamp.

Table 2-1. LED indicator lamps

Lamps		Function
10 Base-T	Link	Solid YELLOW, if connected to 10 Base-T Ethernet network
	Act	Blinks whenever there is any activity on the LS110 Ethernet port
Serial port	Rx/Tx	Blinks whenever there is any incoming or outgoing data through the serial port of the LS110. GREEN on outgoing, RED on incoming.
Status	Ready	Solid GREEN, if system is running and ready to be used.
	Power	Solid RED, if power is supplied



Figure 2-1. The panel layout of the LS110

2.2 Connecting the Hardware

This section describes how to connect the LS110 to the serial device for the first time.

- Connect the power to the LS110
- Connect the Ethernet cable between the LS110 and Ethernet hub or switch
- Connect the serial data cable between the LS110 and a serial device

2.2.1 Connecting the Power

Connect the power jack to the LS110 power jack using DC power adapter included in the package. If the power is properly supplied, the [Power] lamp of the LS110 will maintain solid red.

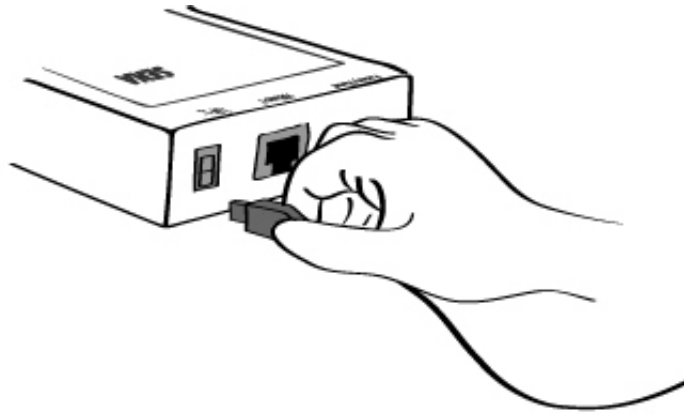

Figure 2-2. Connecting the power to the LS110

2.2.2 Connecting to the Network

Connect the one end of the Ethernet cable to the LS110 10Base-T port and the other to the Ethernet network. If the cable is properly hooked up, the LS110 will have a valid connection to the Ethernet network indicated by:

- [Link] lamp of the LS110 maintains a solid Yellow LED.
- [Act] lamp continuously blinks to indicate the incoming/outgoing Ethernet packets

If any of the above does not happen, the LS110 is not properly connected to the Ethernet network.

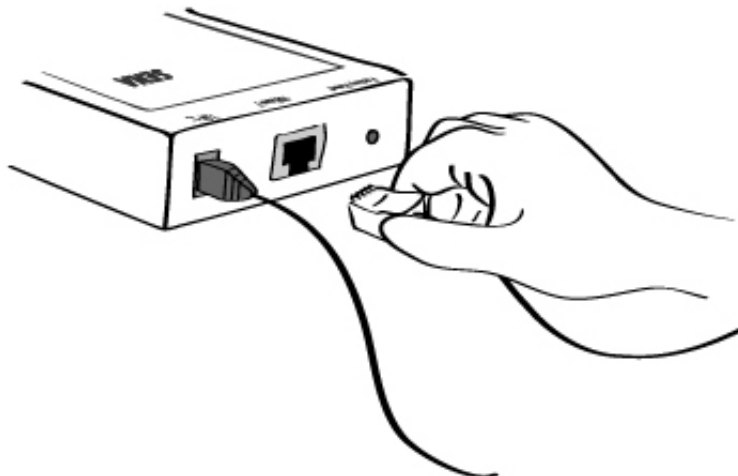

Figure 2-3. Connecting a network cable to the LS110

2.2.3 Connecting to the Device

Connect the serial data cable between the LS110 and the serial device. If necessary, supply power to the serial device attached to the LS110.

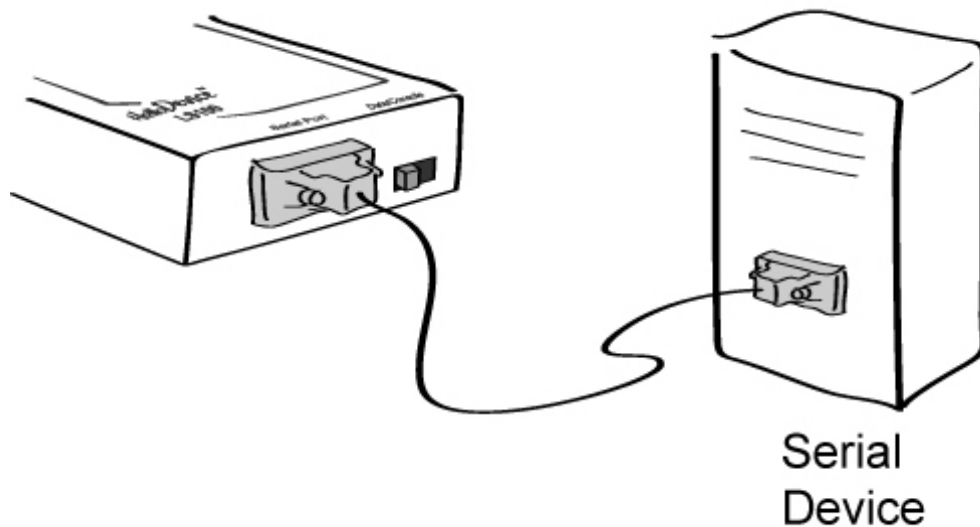

Figure 2-4. Connecting a serial device to the LS110

2.3. Accessing Console Port

There are two ways to access console port of the LS110 depending on whether the user is located at a local site or a remote site.

- Serial console:

Local users can connect directly to the serial console port of the LS110 using serial console/data cable (null-modem cable). The serial port of the LS110 is used as the console port as well as the data port. To use the serial port as the console port, slide Data/Console switch to the Console side.

- Remote console:

Remote users can make a telnet connection to the remote console port (port 23) of the LS110 via TCP/IP network.

Both methods require the user to log into the LS110 in order to continue.

2.3.1 Using Serial Console

- 1) Connect the one end of the serial console cable to the serial port of the LS110.

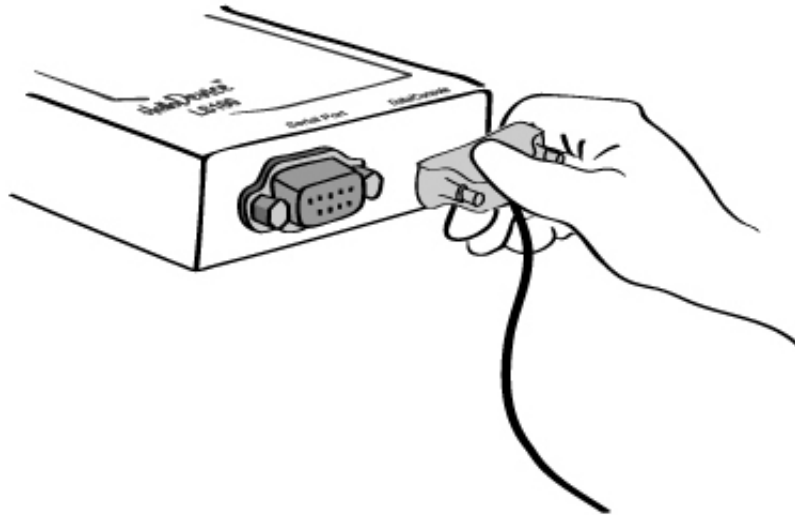

Figure 2-5. Connecting a serial console cable to the LS110

- 2) Connect the other end of the cable to the serial port of user's computer.
- 3) Slide Data/Console switch to Console side.

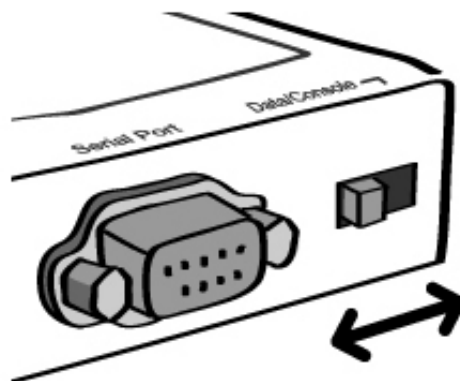

Figure 2-6. Data/Console switch of the LS110

- 4) Run a terminal emulator program such as HyperTerminal. Set up the serial configuration parameters of the terminal emulation program as follows:
Baud rate : 9600 / Data bits : 8 / Parity : None / Stop bits : 1 / No flow control
- 5) Type the user name and password to log into the LS110. A factory default setting of the user

name and password are both 'root'

6) If the user logged into the LS110 successfully, a menu selection screen will appear on the computer as shown in Figure 2-7.

```
LS110 login : root
password : *****

-----
Welcome to LS110 Configuration Page
Serial No. :                               MAC Address : 00:01:95:AF:BD:44
F/W REV.  : v0.4.8                          IP Mode      : Static IP
IP Mode   : Static IP                       IP Address   : 192.168.23.12
-----

Console#1 (Serial) : Connected
Console#2 (Telnet) : Available
Console#3 (Telnet) : Available
-----

1. IP configuration
2. Serial port configuration
3. System information
4. System administration
5. Save changes
6. Exit without reboot
7. Save and reboot
<ESC> Back, <ENTER> Refresh
---->
```

Figure 2-7. The LS110 console screen

At menu selection screen, user can select each menu, by choosing the appropriate number.

Using menu number 5, you can save changes. Menu number 6, you can exit the console without rebooting the device. Selecting option number 7, user can save changes and reboot system simultaneously, after the reboot the reflected changes will be set to LS110.

2.3.2 Using Remote Console

The LS110 provides remote console feature via telnet as well as serial console so that users can access the LS110 at remote site for configuration and monitoring. The IP address of the LS110 must be known before users can access the remote console port. The port number for the remote console is 23, which is a TCP port number assigned for Telnet.

Up to three user can log into the LS110 at the same time.(Maximum Two users in Remote console and one user in Serial console)

To access remote console of the LS110, please use the step as follows:

- 1) Run a telnet program or a program that supports telnet functions such as TeraTerm-Pro or HyperTerminal. The target IP address and the port number should be those of the LS110. If required, specify the port number as 23.

Type the following command in the command line interface of your computer.

```
telnet 192.168.1.254
```

Or run a telnet program with parameters as follows.

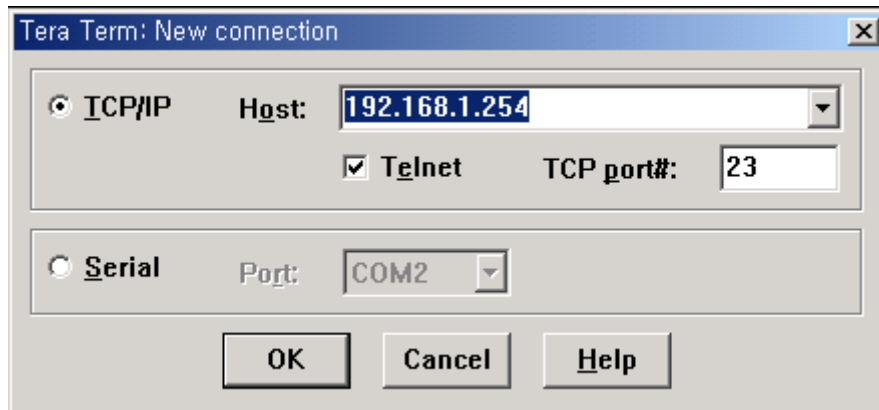

Figure 2-8 Telnet program set up example

- 2) The user has to log into the LS110. Type the user name and password. A factory default setting of the user name and password are both '**root**'.
- 3) If the user logged into the LS110 successfully, the same menu screen, as the one depicted in the serial console will be displayed. At menu selection screen, user can select each menu, by choosing the appropriate number.

3. IP Address Configuration

A valid IP address needs to be assigned before the LS110 starts to work in the user's network environment. A network system administrator may provide the user with this IP address setting information for the network. The IP address must be unique within the network. Otherwise, the LS110 will not have a valid connection .

Users can choose the desired IP mode , i.e., **Static IP and DHCP**. The factory default IP mode is **Static IP** mode. Table 3-1 shows the parameter items for IP configuration.

Table 3-1 IP configuration parameters

Static IP	IP address
	Subnet mask
	Default gateway
DHCP	No parameters required

3.1 Static IP

3.1.1 Overview

In the **Static IP** mode, users have to manually specify all the network parameters such as **IP addresses** of the LS110, valid **subnet mask** and the **default gateway** IP address.

3.1.2 Static IP Configuration

To configure IP configuration parameters of the LS110, use 'IP mode' menu. Basic usage of 'IP mode' is as follows.

```
-----  
Welcome to LS110 Configuration Page  
Serial No. :                               MAC Address : 00:01:95:AF:BD:44  
F/W REV.  : v0.4.8  
IP Mode   : Static IP                       IP Address   : 192.168.23.12  
-----  
Console#1 (Serial) : Connected  
Console#2 (Telnet) : Available  
Console#3 (Telnet) : Available  
-----  
1. IP configuration  
2. Serial port configuration  
3. System information  
4. System administration  
5. Save changes  
6. Exit without reboot  
7. Save and reboot  
<ESC> Back, <ENTER> Refresh
```

```
---> 1

-----
IP configuration
-----

1. IP mode : Static IP
2. IP address : 192.168.23.12
3. Subnet mask : 255.255.0.0
4. Default gateway : 192.168.1.1
5. Primary DNS : 168.126.63.1
6. Secondary DNS : 168.126.63.2
<ESC> Back, <ENTER> Refresh
---> 1

Select IP mode(1 = Static IP, 2 = DHCP)
--->
```

Figure 3-1. Guide line of setting IP mode parameters

If you want to set IP mode to 'Static IP', just select 1 from its parameter values. if 'DHCP', select 2. Following example show the case of 'Static IP'.

```
Select IP mode(1 = Static IP, 2 = DHCP)
---> 1

-----
IP configuration
-----

1. IP mode : Static IP
2. IP address : 192.168.23.12
3. Subnet mask : 255.255.0.0
4. Default gateway : 192.168.1.1
5. Primary DNS : 168.126.63.1
6. Secondary DNS : 168.126.63.2
<ESC> Back, <ENTER> Refresh
--->
```

Figure 3-2. Setting IP mode to Static IP

3.1.3 IP address

In the **Static IP** mode, the IP address is an identification number assigned to a computer as a permanent address on the network. Computers use IP addresses to identify and talk to each other on the network. Choose the proper IP address which is unique and valid on the network environment.

Basic usage of 'IP address'

```
-----
IP configuration
-----

1. IP mode : Static IP
2. IP address : 192.168.23.12
```

```

3. Subnet mask : 255.255.0.0
4. Default gateway : 192.168.1.1
5. Primary DNS : 168.126.63.1
6. Secondary DNS : 168.126.63.2
<ESC> Back, <ENTER> Refresh
----> 2

Enter IP address
---->

```

Figure 3-3. Setting IP address

Enter IP address to be changed.

Note:

The IP address in the form of 192.168.1.x is private in a sense that they are not assigned by an ISP. Application of the LS110 may require sending data back and forth over a public network, such as the Internet. In this case, it is required to assign a valid public IP address. The public IP address is generally purchased or leased from a local ISP.

3.1.4 Subnet mask

A subnet represents all the network hosts at one geographic location, in one building, or on the same local area network.

When there is any outgoing packet over the network, the LS110 will check whether the desired TCP/IP host specified in the packet is on the local network segment with the help of the subnet mask. If the address is proven to be on the same network segment as the LS110, the connection is established directly from the LS110. Otherwise, the connection is established through the given default gateway.

Basic usage of 'Subnet mask'

```

-----
IP configuration
-----
1. IP mode : Static IP
2. IP address : 192.168.23.12
3. Subnet mask : 255.255.0.0
4. Default gateway : 192.168.1.1
5. Primary DNS : 168.126.63.1
6. Secondary DNS : 168.126.63.2
<ESC> Back, <ENTER> Refresh
----> 3

Enter subnet mask
---->

```

Figure 3-4. Setting Subnet mask

Enter subnet mask to be changed.

3.1.5 Default gateway

A gateway is a network point that acts as an entrance to another network. Usually, the computers that control traffic within the network or at the local Internet service provider are gateway nodes. The LS110 needs to know the IP address of the default gateway computer in order to communicate with the hosts outside the local network environment. For correct information on the gateway IP address, please refer to your local network administrator.

Basic usage of 'Default gateway'

```
-----  
IP configuration  
-----  
1. IP mode : Static IP  
2. IP address : 192.168.23.12  
3. Subnet mask : 255.255.255.0  
4. Default gateway : 192.168.1.1  
5. Primary DNS : 168.126.63.1  
6. Secondary DNS : 168.126.63.2  
  <ESC> Back, <ENTER> Refresh  
---> 4  
  
Enter default gateway  
--->
```

Figure 3-5. Setting Default gateway

Enter gateway to be changed.

3.2 DHCP

3.2.1 Overview

Dynamic Host Configuration Protocol (DHCP) is a communications protocol that lets network administrators manage and automate the assignment of IP addresses centrally in an organization's network. DHCP lets a network administrator supervise and distribute IP addresses from a central point and automatically send a new IP address when a computer is plugged into a different place in the network.

As described in the section 3.1, the IP address must be entered manually at each computer in Static IP mode and, if computers move to another location in another part of the network, a new IP address must be entered. Meanwhile, all the parameters including the IP address, subnet mask, gateway, DNS servers will be automatically configured when the IP address is set to DHCP mode. DHCP uses the concept of a "lease" or amount of time for which a given IP address will be valid for a computer. All the

parameters required to assign an IP address are configured on DHCP server side, and each DHCP client computer receives this information when the IP address is provided at its boot-up.

To obtain an IP address, the LS110 sends a corresponding DHCP request as a broadcast over the network after each reset. The reply generated by the DHCP server contains the IP address as well as the subnet mask, gateway address, DNS servers and the lease time. The LS110 immediately places this information in its non-volatile memory. If the operating time reaches the lease time, the LS110 will request the DHCP server for a renewal of its lease time. If the DHCP server approves extending the lease, the LS110 can continue to work with the current IP address. Otherwise, the LS110 will start the procedure to request a new IP address to the DHCP server.

A DHCP sever assigns IP addresses dynamically from an IP address pool, which is managed by the network administrator. This means DHCP client, i.e. the LS110, receives a different IP address each time it boots up. To prevent the case that users do not know the IP address of the LS110 in such environments, its IP address should be reserved on the DHCP server side. In order to reserve the IP address in the DHCP network, the administrator needs the MAC address of the LS110 found on the label sticker located at the bottom of the LS110:

MAC=00:01:95:04:0c:a1

3.2.2 DHCP Configuration

To make the LS110 work in DHCP mode, just set IP mode to DHCP as in Figure 3-2.

```
-----
IP configuration
-----
1. IP mode : Static IP
2. IP address : 192.168.23.12
3. Subnet mask : 255.255.255.0
4. Default gateway : 192.168.1.1
5. Primary DNS : 168.126.63.1
6. Secondary DNS : 168.126.63.2
<ESC> Back, <ENTER> Refresh
---> 1

Select IP mode(1 = Static IP, 2 = DHCP)
--->2
```

Figure 3-6. Setting IP mode to DHCP

3.3 DNS

When users want to visit certain website, the computer asks a Domain Name System (DNS) server for the correct IP address of the web site, and the computer uses the answer to connect to the web server. DNS is the way that Internet domain names are identified and translated into IP addresses. Domain

name is the form of alphanumeric name such as **sena.com** and it is usually easier to remember. A DNS server is a host that can translate such text-based domain names into the numeric IP addresses for TCP/IP connection.

In order to use this DNS feature of the LS110, users need to set the IP address of this DNS server to be able to access the host with the domain name. The LS110 provides the way to configure IP addresses of DNS servers, i.e. **Primary DNS server, Secondary DNS server**. A secondary DNS server is specified for use when the primary DNS server is unavailable

3.3.1 Primary DNS Configuration

Basic usage of setting 'Primary DNS' variable is as follows.

```
-----  
IP configuration  
-----  
1. IP mode : Static IP  
2. IP address : 192.168.23.12  
3. Subnet mask : 255.255.0.0  
4. Default gateway : 192.168.1.1  
5. Primary DNS : 168.126.63.1  
6. Secondary DNS : 168.126.63.2  
  <ESC> Back, <ENTER> Refresh  
----> 5  
  
Enter primary DNS  
---->
```

Figure 3-7. Setting Primary DNS

3.3.2 Secondary DNS Configuration

Basic usage of setting 'Secondary DNS' variable is as follows.

```
-----  
IP configuration  
-----  
1. IP mode : Static IP  
2. IP address : 192.168.23.12  
3. Subnet mask : 255.255.0.0  
4. Default gateway : 192.168.1.1  
5. Primary DNS : 168.126.63.1  
6. Secondary DNS : 168.126.63.2  
  <ESC> Back, <ENTER> Refresh  
----> 6  
  
Enter secondary DNS  
---->
```

Figure 3-8. Setting Secondary DNS

4. Host Mode Configuration

4.1 Host mode

4.1.1 Overview

Host mode represents the operating session mode of the LS110. Several host modes are available for the data communication between serial devices and remote hosts.

Table 4-1. The LS110 session modes

Mode	Description
TCP server	Select this mode, when users want the LS110 to operate as a TCP server. The LS110 stands by until there is any TCP connection request. If TCP connection is not already established at that time, the LS110 accepts the request and the session is established. In the established state, it transmits the data through the corresponding serial port if there is any data from the remote host. Since the LS110 supports only one TCP session per serial port, the additional TCP connection request will be rejected.
TCP client	Select this mode, when users want the LS110 to operate as a TCP client. When the serial device sends data or pre-defined timer is expired, the LS110 tries to establish a TCP connection to a remote server through its TCP port. If a TCP session is established between them, the LS110 will send data to the server. If there's any data from the server during the session, it will also send the data through the serial port. However, if the LS110 failed to connect to the remote server, the data from the serial port will be discarded.
TCP server/client	If you are not sure which mode to choose, select this mode since it will be applied in most applications. In this mode, the LS110 operates as TCP server AND client. If the connection is not established, it will accept all incoming connection and connect to the remote host if there are any data from the serial device. Otherwise, it will send data back and forth. In summary, the LS110 will work as if it is virtually connected to the remote host.
UDP tunneling	The UDP tunneling mode operation is similar to that of <i>TCP server/client</i> mode except that it is based on UDP protocol and only one pre-defined remote host is able to communicate with the LS110.
UDP server	While UDP tunneling mode allows only one remote host for UDP communications, UDP server mode allows any remote host to access the LS110. In this mode, the LS110 gets the information on the remote host from the latest incoming datagram information.
Modem emulation	Select this mode when the serial device supports modem AT commands or users want to perform the session control by using AT commands. Only a TCP session is supported.
Telnet Server	This mode enables your existing serial communication program to be used over the network allowing you to keep using your existing program without any modification. This mode is similar to TCP Server. This mode supports the Telnet protocol over TCP, and RFC2217.

For each host mode, required parameters for configuration are summarized in Table 4-2.

Table 4-2 Host mode configuration parameters

host_mode	parameter name	Description
TCP Server	local_port	Local Port
	dtr_behavior	DTR Behavior
	dsr_behavior	DSR Behavior
	inactivity_timeout	Inactivity Timeout
	allowed_ip	IP that enables to connect to LS110
	allowed_subnet	Subnet that enables to connect to LS110
TCP Client	dest_ip	Destination IP Address
	dest_port	Destination Port
	dtr_behavior	DTR behavior
	dsr_behavior	DSR behavior
	cyclic_connection	Cyclic Connection Time
	inactivity_timeout	Inactivity Timeout
	allowed_ip	IP that enables to connect to LS110
	allowed_subnet	Subnet that enables to connect to LS110
TCP Server/Client	local_port	Local Port
	dest_ip	Destination IP Address
	dest_port	Destination Port
	dtr-behavior	DTR Behavior
	dsr_behavior	DSR Behavior
	cyclic_connection	Cyclic Connection Time
	inactivity_timeout	Inactivity Timeout
	allowed_ip	IP that enables to connect to LS110
	allowed_subnet	Subnet that enables to connect to LS110
UDP Tunneling	Local port	Local Port
	dest_ip	Destination IP Address
	dest_port	Destination Port
UDP Server	Local port	Local Port
	inactivity_timeout	Inactivity Timeout
Modem Emulation	None	Set required parameter by its modem commands.
	local_port	Local Port
Telnet Server	dtr_behavior	DTR Behavior
	dsr_behavior	DSR Behavior
	inactivity_timeout	Inactivity Timeout
	allowed_ip	IP that enables to connect to LS110
	allowed_subnet	Subnet that enables to connect to LS110

For easier understanding of TCP modes, a simplified **State Transition Diagram** is often used. And to help users understand the diagram, the TCP state of the LS110 is briefly described as follows.

- Listen

It represents “a waiting for a connection request from any remote host”. It is a default start-up mode when it is set as *TCP server* mode. This state is valid only in *TCP server* mode operation.

- Closed

It means “No connection state at all”. If the data transfer is completed, the state is changed to this state if one of the host requests disconnection request. If it is in *TCP server* mode, the state is automatically changed to [Listen] mode. It is a default start-up mode when it is set as *TCP client* mode or *TCP server/client* mode.

- Sync-Received

In *TCP server* mode, the state will be changed from [Listen] to [Sync-Received], if any remote host sends connection request. If the LS110 accepts the request, the state will be changed into [Established]. This state is not valid in *TCP client* mode.

- Sync-Sent

If the LS110 sends a connection request to a remote host, the state is changed from [Closed] to [Sync-Sent]. This state is maintained until the remote host accepts the connection request. This state is valid only in *TCP client* mode.

- Established

It represents “an open connection”. If one of the hosts accepts a connection request from the other host, the connection is opened and state is changed into [Established].

- Data

When it is in [Established] state, data from a host will be transferred to the other one. For easier understanding of the TCP session operation, we called the state as [Data] state when actual data transfer is performed. Actually, the [Data] mode is a part of [Established] state as is described in the RFC 793 [Transmission Control Protocol]. This is a normal state for the data transfer phase of the connection.

4.1.2 TCP server mode operations

The LS110 in this mode acts as a TCP server, and the default TCP state is [Listen] in this mode. The LS110 supports only one TCP socket connection per one serial port. If a connection is currently established, any additional connection requests will be rejected. The remote host will be either Ethernet-Serial communication devices acting as a TCP client or a socket program acting as a TCP client running on users' PC.

1) Typical State Transition

[Listen] --> [Sync-Received] --> [Established] --> [Data] --> [Closed] --> [Listen]

At start-up, an initial TCP state is [Listen]. If there is any incoming TCP connection request, the state will be changed into [Sync-Received], then [Established], which means a session is opened. For a while, data will be transferred between the hosts. This is the [Data] state. The session will be disconnected due to the request of one of them, which is [Closed] state. And then, the state is automatically changed to its original state, [Listen].

2) Operations

Serial data transfer

When a session has been established, the LS110 reads the data from the serial port buffer till internal serial buffer is full or inter-character time interval reaches the time specified as *inter-character timeout* value. Then, it transfers the data to the IP address (or domain name) of the remote host (See *Options* in section 4.3 for more details on *inter-character timeout*). If there's no remote host connected to the LS110, all the incoming data from the serial port are discarded.

Session disconnection

The connected session will be disconnected when the remote host sends disconnection request or when no data transfer activity is found through the serial port for a certain amount of time, which is "*Inactivity timeout*" (See *Options* in section 4.3 for details on *Inactivity timeout*).

IP Filtering

LS110 offers 'IP Filtering' (See IP Filtering in section 4.3.4 for details).

Figure 4-1 shows the State Transition Diagram of the session operations in *TCP server mode*.

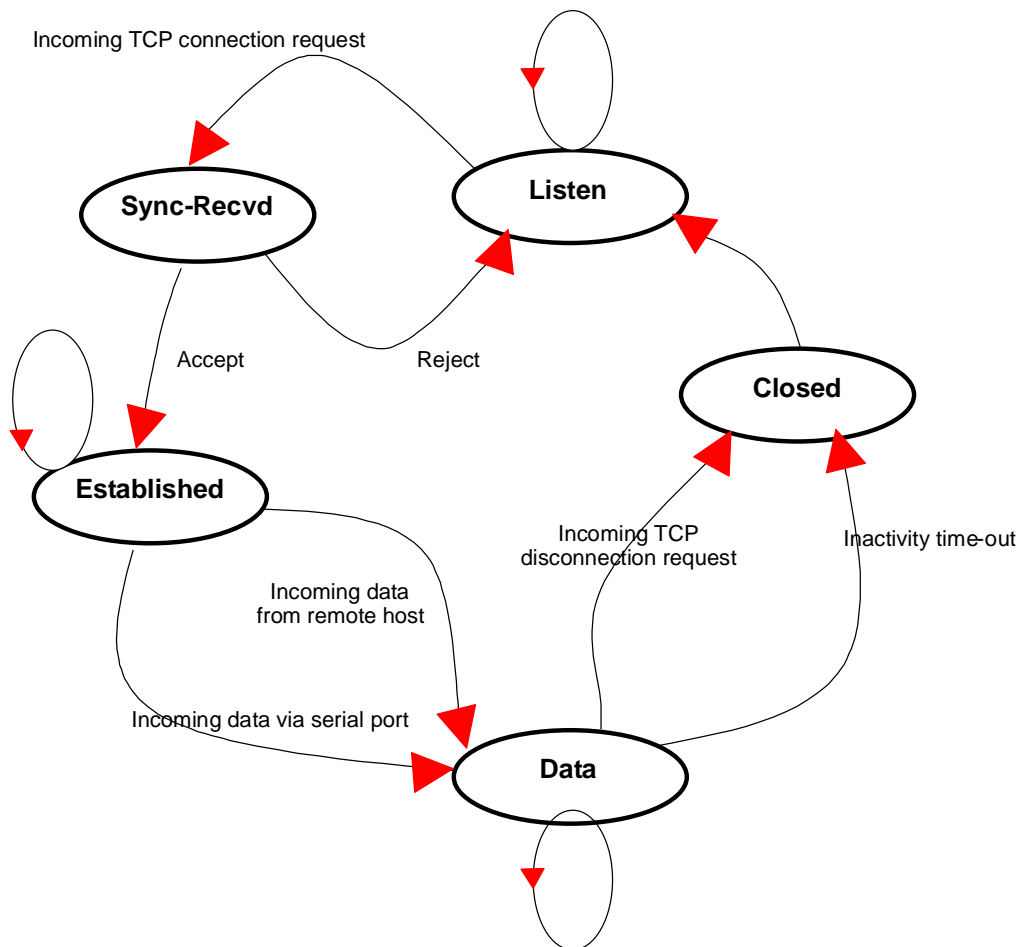

Figure 4-1. State Transition Diagram of *TCP server mode*

3) Parameters

Local port

This is the TCP port number through which remote host can connect a TCP session, and, send and receive data. Incoming connection request to the ports other than *Local Port* will be rejected. The LS110 does not restrict the number to a specific range, but it is strongly recommended not to use the well-known ports for certain application (See Appendix B. *Well-known Port Numbers*). To change the port number, refer to next example.

```

-----
Welcome to LS110 Configuration Page
Serial No. : LS          MAC Address : 00:01:95:FF:DC:A9
F/W REV.  : v0.4.8
IP Mode   : Static IP   IP Address  : 192.168.23.12
-----

Console#1 (Serial) : Available
Console#2 (Telnet) : Available
Console#3 (Telnet) : Connected
-----

1. IP configuration
2. Serial port configuration
3. System information
4. System administration
5. Save changes
6. Exit without reboot
7. Save and reboot
<ESC> Back, <ENTER> Refresh
---> 2

-----

Serial port configuration
-----

1. Baud rate : 9600
2. Data bits : 8
3. Parity : None
4. Stop bit(s) : 1
5. Flow control : Hardware
6. Inter-character timeout : 0
7. Host mode : Telnet Server
8. Local port : 6001
9. Inactivity timeout : 0
10. DTR behavior : Always HIGH
11. DSR behavior : None
12. Allowed IP : 0.0.0.0
13. Allowed subnet : 0.0.0.0
<ESC> Back, <ENTER> Refresh
---> 8

Enter local port number
--->

```

Figure 4-2. Changing Local TCP Port number

4.1.3 TCP client mode operations

The LS110 acts as a TCP client, and the default TCP state is [Closed] in this mode. The remote host will be either Ethernet-Serial communication devices acting as a TCP server or a socket program acting as a TCP server running on users' PC.

1) Typical State Transition

[Closed] --> [Sync-Sent] --> [Established] --> [Data] --> [Closed]

At start-up, an initial TCP state is [Closed]. If there is any incoming data through the serial port, the LS110 will try to connect to a user-defined remote host. Then, the state will be changed to [Sync-Sent],

which means the connection request is being sent. If the remote host accepts the request, the state will be changed into [Established], which means a session has been opened. For a while, data will be transferred between the hosts. This is [Data] state. The session will be disconnected due to the request of one of them, which is its original state, [Closed].

2) Operations

Serial data transfer

Whenever the serial device sends data through the serial port of the LS110, data will be accumulated to the serial port buffer of the LS110. If the internal serial port buffer is full or inter-character time interval reaches to the time specified as *inter-character timeout* value, it tries to connect to the user-defined IP address (or domain name) of the remote host, if TCP session is not established yet (See *Options* in section 4.3 for details on *inter-character timeout*). If the LS110 succeeds in connecting to the remote host, the data in the serial port buffer will be transferred to the host. Otherwise, all the data stored in the buffer will be cleared.

Session disconnection

The connected session will be disconnected when the remote host sends disconnection request or when no data transfer activity is found through the serial port for certain amount of time, which is "*Inactivity timeout*" (See *Options* in section 4.3 for details on *Inactivity timeout*). All the data remained in the serial port buffer will be cleared when it is disconnected.

Connection request from remote host

All the incoming TCP connection requests will be rejected in *TCP client* mode.

Cyclic Connection

If *Cyclic Connection* function is enabled, the LS110 will make an attempt to connect to the user-defined remote host at certain interval even if there's no incoming serial data from the device. If the remote host prepares certain data, it will be transferred to the serial device via its serial port after the connection is established. Eventually, users can monitor the serial device periodically by making the remote host send the serial command to the LS110 whenever it is connected to the remote host. This option is useful when users need to gather the device information periodically even if the serial device does not send its data periodically. Figure 4-3 shows the State Transition Diagram of the session operations in *TCP client* mode.

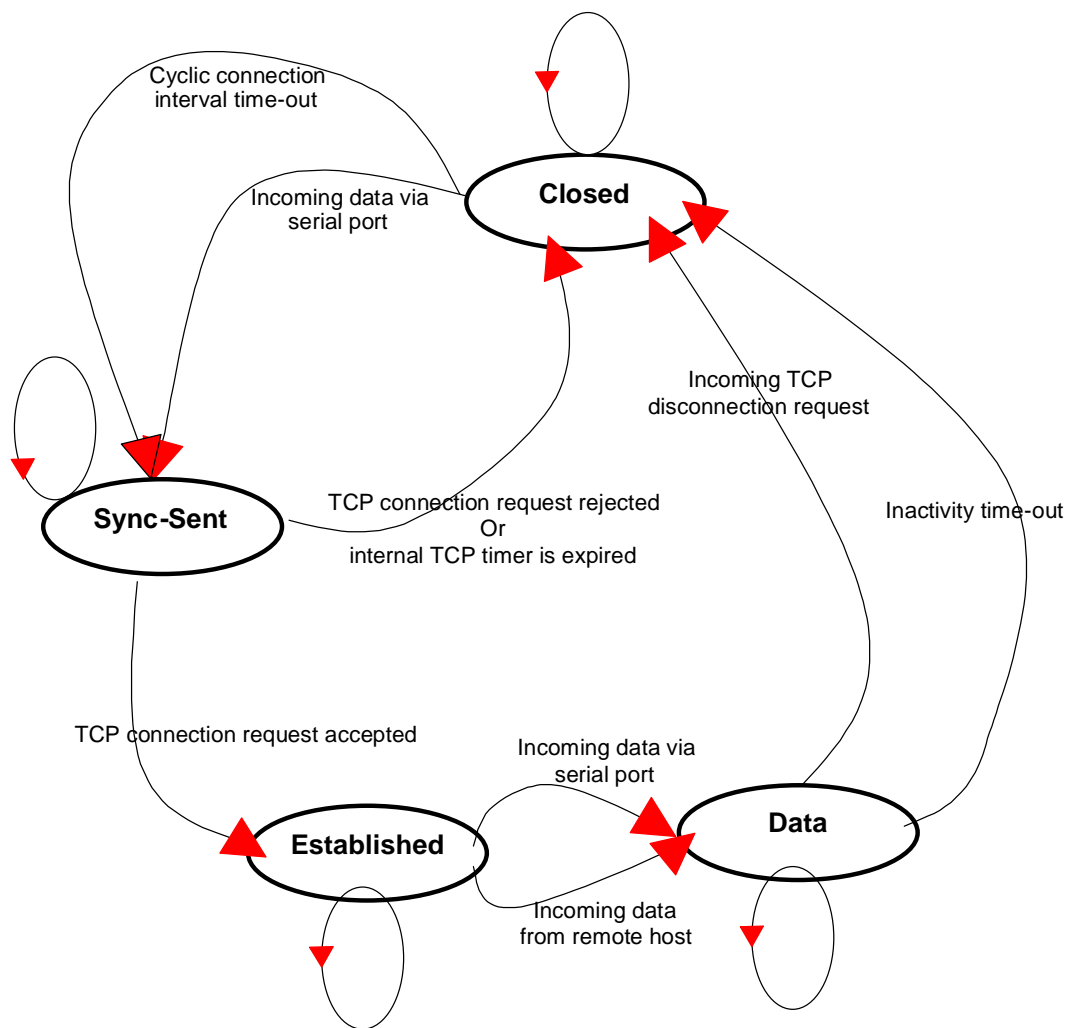

Figure 4-3. State Transition Diagram of TCP client mode

3) Parameters

Remote IP address (or domain name) and Remote Port

This is the information on the remote host to which the LS110 will try to connect in *TCP client* mode. The IP address (or domain name) should be specified together with the TCP port number. To specify the information on the remote host IP and port, refer to following examples.

```
-----  
Serial port configuration  
-----  
1. Baud rate : 9600  
2. Data bits : 8  
3. Parity : None  
4. Stop bit(s) : 1  
5. Flow control : Hardware  
6. Inter-character timeout : 0  
7. Host mode : TCP Client  
8. Destination IP : 0.0.0.0  
9. Destination port : 7001  
10. Inactivity timeout : 0  
11. Cyclic connection : 0  
12. DTR behavior : Always HIGH  
13. DSR behavior : None  
14. Allowed IP : 0.0.0.0  
15. Allowed subnet : 0.0.0.0  
<ESC> Back, <ENTER> Refresh  
---> 8  
  
Enter destination IP address  
---> 192.168.23.30  
  
-----  
Serial port configuration  
-----  
1. Baud rate : 9600  
2. Data bits : 8  
3. Parity : None  
4. Stop bit(s) : 1  
5. Flow control : Hardware  
6. Inter-character timeout : 0  
7. Host mode : TCP Client  
8. Destination IP : 192.168.23.30  
9. Destination port : 7001  
10. Inactivity timeout : 0  
11. Cyclic connection : 0  
12. DTR behavior : Always HIGH  
13. DSR behavior : None  
14. Allowed IP : 0.0.0.0  
15. Allowed subnet : 0.0.0.0  
<ESC> Back, <ENTER> Refresh  
---> 9  
  
Enter destination port number  
---> 7004
```

Figure 4-4. Set up remote host information

Cyclic connection interval

The time interval at which the LS110 will try to connect to the remote host regardless of the existence of incoming data from the serial port. If the interval is specified with a valid value other than 0, the function is enabled. The time interval will be the specified value by the unit of second.

```
-----  
Serial port configuration  
-----  
1. Baud rate : 9600  
2. Data bits : 8  
3. Parity : None  
4. Stop bit(s) : 1  
5. Flow control : Hardware  
6. Inter-character timeout : 0  
7. Host mode : TCP Client  
8. Destination IP : 192.168.23.30  
9. Destination port : 7001  
10. Inactivity timeout : 0  
11. Cyclic connection : 0  
12. DTR behavior : Always HIGH  
13. DSR behavior : None  
14. Allowed IP : 0.0.0.0  
15. Allowed subnet : 0.0.0.0  
<ESC> Back, <ENTER> Refresh  
---> 11  
  
Enter cyclic connection interval in second(0=Disable)  
--->
```

Figure 4-5. Set up Cyclic Connection interval

4.1.4 TCP server/client mode operations

The LS110 works as either TCP server or client depending on where the data originates from. In its default state the LS110 will be in the [Listen] state, if the data should arrive from the Ethernet side first, the LS110 will act as a TCP server. If the data should arrive from the serial port, the LS110 will act as a TCP client.

1) Typical State Transition

[Listen] --> [Sync-Received] --> [Established] --> [Data] --> [Closed] --> [Listen]

Or

[Listen] --> [Sync-Sent] --> [Established] --> [Data] --> [Closed] --> [Listen]

The initial state is [Listen]. If there are data coming from the serial port, it will connect to the remote host as a TCP client. If there is incoming connection request from the remote host, it will accept the connection as a TCP server, and then transfer data through the serial port. Thus, users can assume that the LS110 is always connected to the specified remote host.

2) Operations

The only difference from *TCP server* mode is that the LS110 will try to connect and send serial data to the remote host even if the TCP session is not established. The difference from *TCP client* mode is

that it will accept incoming connection request from remote host if the session is not established. The detailed operation principles are the same as that of *TCP server* and *TCP client* mode. See section 4.1.2 and 4.1.3 for more details on each session mode.

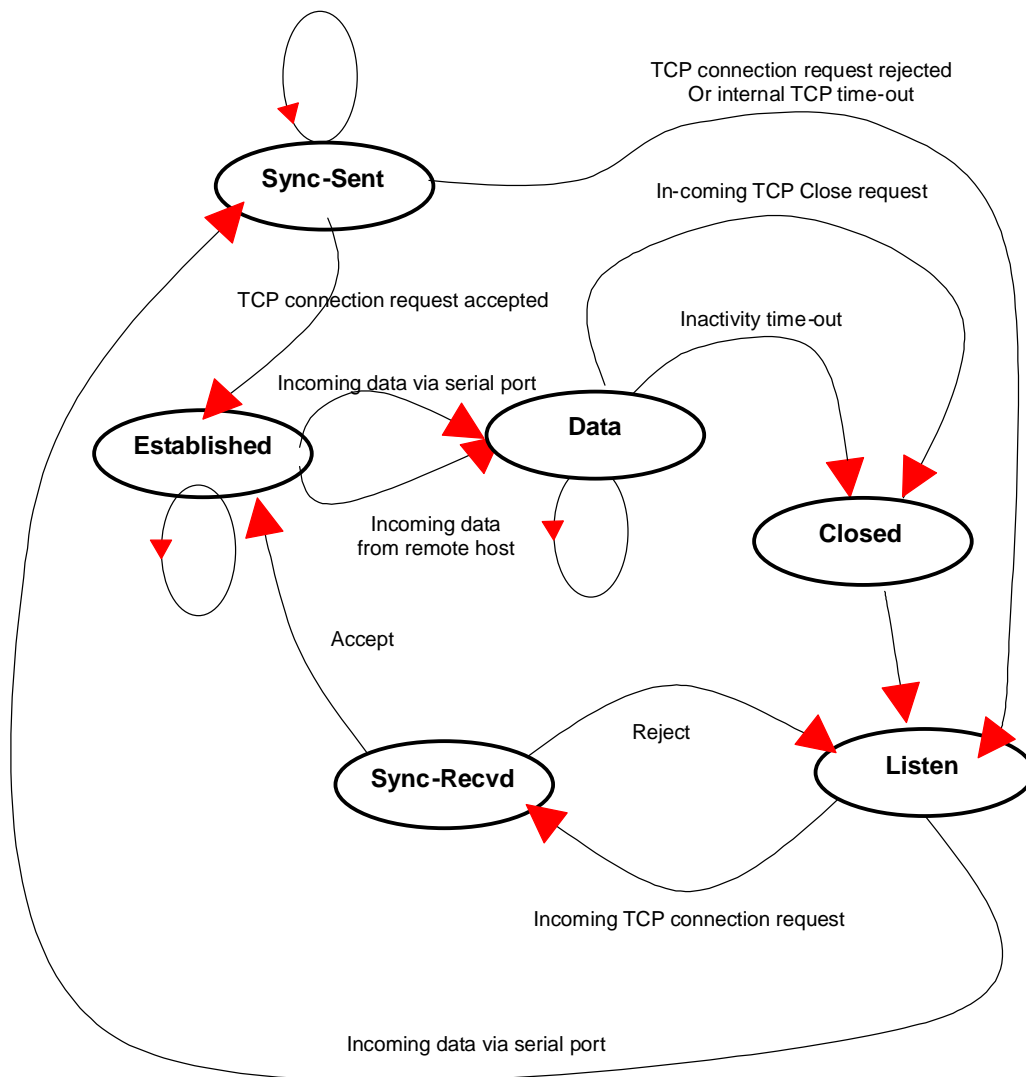

Figure 4-6. State Transition Diagram of TCP server/client mode

3) Parameters

Local Port

See section 4.1.2 for details

Remote IP address (or domain name) and Remote Port

See section 4.1.3 for details

Cyclic connection interval

See section 4.1.3 for details

4.1.5 UDP tunneling mode operations

The UDP tunneling mode operation is similar to that of *TCP server/client* mode except that it is based on UDP protocol and only one pre-defined remote host is able to communicate with the LS110. Users do not have to configure the parameter of *inactivity timeout*, since UDP is a connectionless protocol.

1) Operations

If a remote host sends a UDP datagram to the UDP *Local port* of the LS110, it checks if the IP address of the host is the same as the pre-defined *Destination IP* address. If the IP addresses are the same, the LS110 transfers the data through the serial port. Otherwise, the LS110 discards the incoming UDP datagram.

If there is any incoming data from the serial port, the LS110 transfers the data to the remote host defined as *Destination IP & Port*. Although the remote port is not open, the LS110 does not transfer the data again.

2) Parameters

Local port

The concept is the same as that of TCP communication. See *TCP Server mode operations* in the section 4.1.2 for details.

Remote IP address (or domain name) and Remote Port

The concept is the same as that of TCP communication. See *TCP Client mode operations* in the section 4.1.3 for details.

4.1.6 UDP server mode operations

While UDP tunneling mode allows only one remote host for UDP communications, UDP server mode allows any remote host to access the LS110. In this mode, the LS110 gets the information on the remote host from the latest incoming datagram information and keeps this information for *inactivity timeout* management (see 4.3.2 for detail).

1) Operations

In UDP server mode, a remote host should initiate UDP data communication. If there is any incoming UDP datagram to the LS110, it will make a virtual connection with the remote host for *inactivity timeout* duration. Before the *inactivity timeout* value expires, the LS110 transfers the UDP data to the serial port, and send back the data from the serial port to the latest remote host who sent the UDP datagram. Virtual connection timeout will be reset to *inactivity timeout* value whenever there is any data transfer between remote host and the serial device. If other remote hosts send UDP datagrams while a virtual

connection is established, the UDP datagram will be discarded. If there is no data transfer during *inactivity timeout*, the virtual connection will be closed and other remote hosts can access the LS110 from then on.

2) Parameters

Local port

The concept is the same as that of TCP communication. See *TCP Server mode operations* in the section 4.1.2 for details.

4.1.7 Modem emulation mode operations

In modem emulation mode, the serial port process acts as if it is a modem attached to the serial device. It accepts and sends AT modem commands, and answers to them, as modems would. It also handles the modem signals correctly. Modem emulation mode is useful in the following cases.

- There already exists a modem attached to the users' serial device.

If users' serial device already has a modem for phone-line connection, it can be just replaced by the LS110 for Ethernet connection. What users need to do is to use an IP address (or domain name) instead of phone number as a parameter of ATA/ATDT commands.

- It is required to send serial data to the multiple remote hosts.

If the serial device should send data to the multiple hosts, modem emulation mode is required. For example, the first data from the serial device can be sent to the first data acquisition server and the second to the second server. What user device has to do is to change the IP address (or domain name) parameter whenever the device sends ATD(T) XXX command.

By using the modem emulation mode of the LS110, users can have their serial device connected to the Ethernet network easily. Table 4-3 is a summarized AT command table which the LS110 supports. Table 4-4 is a summarized AT commands response numeric codes. Figure 4-7 shows the typical case of the serial port command flow when AT command is used to connect to the Ethernet network.

Table 4-3. AT commands supported in the LS110

Command	Internal Operation	Response ¹ (Verbose Code)
+++	Return to command input mode	OK
ATD(T) [remote IP or domain name]:[remote port] [CR][LF] or ATD(T) [remote IP][remote port] [CR][LF]	Set TCP mode as TCP client mode. And then, try to connect to the specified remote host. e.g. atdt192.168.1.9:1002 e.g. atdt1921680010091002 Connect to IP address, 192.168.1.9, port 1002 (Port Number is permitted from 1 to 65534) e.g. atdtps.sena.com:1002 Connect to domain address ps.sena.com, port 1002	If success, CONNECT [CR][LF] If failure in connection, NO CARRIER [CR][LF] If other errors, ERROR [CR][LF]
AT or ATZ [CR][LF]	Initialize TCP socket and serial port	If success, OK [CR][LF] If failure, ERROR [CR][LF]
ATA/ [CR][LF]	Repeat last command	
ATA [Local port number] [CR][LF]	Set TCP mode as TCP server mode. And then, set TCP state as [Listen].	
ATEn [CR][LF]	E, E0: Disable echo E1: Enable echo	
ATOn [CR][LF]	O, O0: Turn to data mode	
ATQn [CR][LF]	Q, Q0: Response display on (default) Q1: Response display off	
ATVn [CR][LF]	V, V0: Response = <numeric code> [CR][LF] V1 (default): Response = <verbose code> [CR][LF]	
AT&Dn [CR][LF]	D, D0: ignore DTR(PC) signal D2(default): disconnect TCP session	
AT&Fn [CR][LF]	F, F0, F1: Restore default modem settings	
AT&Kn [CR][LF]	K, K0: No flow control K3: RTS/CTS flow control (default)	
AT&Sn [CR][LF]	S, S0: DSR(PC) always high S1: DSR(PC) shows TCP connection	
ATHn [CR][LF]	H, H0: Disconnect current TCP connection All the data will be cleared H1: Keep the current TCP connection	
ATIn [CR][LF]	I, I0 : display "Sena Technologies, Inc." I3 : display model number Others : display "OK"	<=
AT\Tn [CR][LF]	Set inactivity timer to n minutes \T, \T0: inactivity timer disabled (default)	OK [CR][LF]

¹ If Echo mode is enabled, the command will be sent back first. And then, corresponding response will be sent. If disabled, only response will be sent.

ATBn, ATCn, ATLn, ATMn, ATNn, ATP, ATT, ATYn, AT%Cn, AT%En, AT&Bn, AT&Gn, AT&In, AT&Qn, AT&V, ATMn, ATAn, AT\Bn, AT\Nn, ATXn	None	OK [CR][LF]
ATSn?, ATSn=x	Internal S-register can be set or read. Default values are shown on Table 4-5 Changed values are not preserved if th power is off.	<=
AT&Cn, AT&Wn, AT&Zn=x	response is ERROR.	ERROR [CR][LF]
ATFn [CR][LF]	None	If n=1 OK [CR][LF] If others, ERROR [CR][LF]
ATWn	None	If n=0 OK [CR][LF] If others, ERROR [CR][LF]

Table 4-4. AT commands Response Code

Verbose Code (After "ATV1" command executed)	Numeric Code (After "ATV0" command executed)	Description
OK	0	Command executed
CONNECT	1	Modem connected to line
RING	2	A ring signal has been detected
NO CARRIER	3	Modem lost carrier signal
ERROR	4	Invalid command

Table 4-5 Default value of S-Registers

Index	Default Value	Index	Default Value	Index	Default Value
0 ~1	0	2	43	3	13
4	10	5	8	6	2
7	30	8	2	9	6
10	14	11	100	12	50

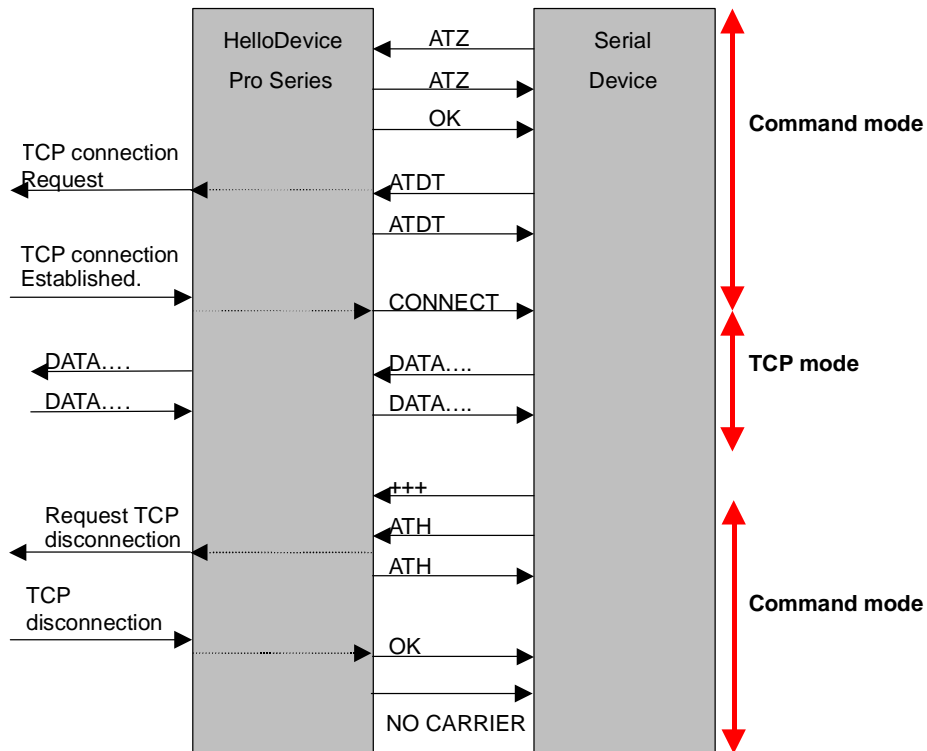

Figure 4-7. Typical case of command/data flow of modem emulation mode

4.1.8 Telnet Server mode

LS110 supports Telnet COM Port Control Option (RFC2217 compliant) so that user can control serial parameters like baud rate, data bits and flow control option using his local RFC2217-compliant Telnet client program. (Please refer to section 4.2 *Serial port Configuration* for more detail information about serial parameters)

Usually this option is used with the RFC2217-compliant COM port redirector so that user can control parameters of serial ports of LS110 using his serial port application program. For this purpose, SENA OEM version of Serial/IP from Tactical Software, LLC is bundled with LS110. Please refer to documentations of Serial/IP for more detail information about using the COM port redirector.

1) Parameters

Local Port

See section 4.1.2 for details

4.2 Serial Port configuration

To attach the serial device to the LS110 serial port, its serial settings should match exactly to that of the serial device.

4.2.1 Baud rate

Baud rate settings for the LS110 is as follows.

1200, 2400, 4800, 9600, 19200, 38400, 57600 and 115200

The baud rate can be changed by 'Baud rate' menu of 'Serial port configuration'.

```
-----  
Serial port configuration  
-----  
1. Baud rate : 9600  
2. Data bits : 8  
3. Parity : None  
4. Stop bit(s) : 1  
5. Flow control : Hardware  
6. Inter-character timeout : 0  
7. Host mode : TCP Client  
8. Destination IP : 192.168.23.30  
9. Destination port : 7001  
10. Inactivity timeout : 0  
11. Cyclic connection : 0  
12. DTR behavior : Always HIGH  
13. DSR behavior : None  
14. Allowed IP : 0.0.0.0  
15. Allowed subnet : 0.0.0.0  
<ESC> Back, <ENTER> Refresh  
---> 1  
  
Select baud rate  
1 = 1200, 2 = 2400, 3 = 4800, 4 = 9600  
5 = 19200, 6 = 38400, 7 = 57600, 8 = 115200  
--->
```

Figure 4-8. Set up the baud rate

4.2.2 Data bits, Stop bit(s), Parity

The factory default setting of *data bits*, *stop bits* and *parity* are 8, 1 and None. They can be changed using each menu such as 'Data bits', 'Stop bit(s)', and 'Parity'.

```
-----  
Serial port configuration  
-----  
1. Baud rate : 9600  
2. Data bits : 8  
3. Parity : None  
4. Stop bit(s) : 1  
5. Flow control : Hardware  
6. Inter-character timeout : 0  
7. Host mode : TCP Client  
8. Destination IP : 192.168.23.30  
9. Destination port : 7001  
10. Inactivity timeout : 0  
11. Cyclic connection : 0  
12. DTR behavior : Always HIGH  
13. DSR behavior : None  
14. Allowed IP : 0.0.0.0  
15. Allowed subnet : 0.0.0.0  
<ESC> Back, <ENTER> Refresh  
---> 2  
  
Select data bits (1 = 7 Bits, 2 = 8 Bits)  
--->2
```

Figure 4-9. Set up the Data bits

```
-----  
Serial port configuration  
-----  
1. Baud rate : 9600  
2. Data bits : 8  
3. Parity : None  
4. Stop bit(s) : 1  
5. Flow control : Hardware  
6. Inter-character timeout : 0  
7. Host mode : TCP Client  
8. Destination IP : 192.168.23.30  
9. Destination port : 7001  
10. Inactivity timeout : 0  
11. Cyclic connection : 0  
12. DTR behavior : Always HIGH  
13. DSR behavior : None  
14. Allowed IP : 0.0.0.0  
15. Allowed subnet : 0.0.0.0  
<ESC> Back, <ENTER> Refresh  
---> 4  
  
Select stop bit(s) (1 = 1 Bit , 2 = 2 Bits)  
---> 1
```

Figure 4-10. Set up Stop bit(s)

```
-----  
Serial port configuration  
-----  
1. Baud rate : 9600  
2. Data bits : 8  
3. Parity : None  
4. Stop bit(s) : 1  
5. Flow control : Hardware  
6. Inter-character timeout : 0  
7. Host mode : TCP Client  
8. Destination IP : 192.168.23.30  
9. Destination port : 7001  
10. Inactivity timeout : 0  
11. Cyclic connection : 0  
12. DTR behavior : Always HIGH  
13. DSR behavior : None  
14. Allowed IP : 0.0.0.0  
15. Allowed subnet : 0.0.0.0  
<ESC> Back, <ENTER> Refresh  
---> 3  
  
Select parity (1 = None, 2 = Odd, 3 = Even)  
---> 1
```

Figure 4-11. Set up Parity

4.2.3 Flow control

The factory default setting of flow control is *None*. Only hardware flow control using RTS/CTS is supported by the LS110. Hardware flow control method controls data communication flow by sending signals back and forth between two connected devices.

It can be configured using 'Flow control' menu.

```
-----  
Serial port configuration  
-----  
1. Baud rate : 9600  
2. Data bits : 8  
3. Parity : None  
4. Stop bit(s) : 1  
5. Flow control : Hardware  
6. Inter-character timeout : 0  
7. Host mode : TCP Client  
8. Destination IP : 192.168.23.30  
9. Destination port : 7001  
10. Inactivity timeout : 0  
11. Cyclic connection : 0  
12. DTR behavior : Always HIGH  
13. DSR behavior : None  
14. Allowed IP : 0.0.0.0  
15. Allowed subnet : 0.0.0.0  
<ESC> Back, <ENTER> Refresh  
---> 5  
  
Select flow control (1 = None, 2 = Hardware)  
--->
```

Figure 4-12. Set up the Flow control

4.3 Options

4.3.1 DTR/DSR behavior

The purpose of the DTR/DSR pins is to emulate modem signal control or to control TCP connection state. The DTR is a write-only output signal, whereas the DSR is a read-only input signal, on the LS110.

The DTR output behavior can be set to one of three types: *Always HIGH*, *Always LOW* or *Show TCP connection*. If the DTR behavior is set to *Show TCP connection*, the state of the DTR pin will be maintained high if the TCP connection is established.

The DSR input behavior can be set to one of three types: *None*, *Open/Close TCP connection* or *Allow TCP connection only by HIGH*. *Open/Close TCP connection* is valid only if the host mode is a TCP client or equivalent. If the DSR behavior is set to *Open/Close TCP connection*, the high state of the DSR pin will make the LS110 send a connection request to the specified destination host, whereas the low state close a connection. *Allow TCP connection only by HIGH* is valid only if host mode is TCP server or equivalent. If this option is set, the incoming TCP connection request will be accepted only when the DSR signal is high state.

```
-----  
Serial port configuration  
-----  
1. Baud rate : 9600  
2. Data bits : 8  
3. Parity : None  
4. Stop bit(s) : 1  
5. Flow control : Hardware  
6. Inter-character timeout : 0  
7. Host mode : TCP Client  
8. Destination IP : 192.168.23.30  
9. Destination port : 7001  
10. Inactivity timeout : 0  
11. Cyclic connection : 0  
12. DTR behavior : Always HIGH  
13. DSR behavior : None  
14. Allowed IP : 0.0.0.0  
15. Allowed subnet : 0.0.0.0  
<ESC> Back, <ENTER> Refresh  
---> 12  
  
Select DTR output behavior  
  1 = Always HIGH  
  2 = Always LOW  
  3 = Show TCP connection (HIGH while connected)  
--->
```

Figure 4-13. Set up the DTR output behavior

```
-----
Serial port configuration
-----
1. Baud rate : 9600
2. Data bits : 8
3. Parity : None
4. Stop bit(s) : 1
5. Flow control : Hardware
6. Inter-character timeout : 0
7. Host mode : TCP Client
8. Destination IP : 192.168.23.30
9. Destination port : 7001
10. Inactivity timeout : 0
11. Cyclic connection : 0
12. DTR behavior : Always HIGH
13. DSR behavior : None
14. Allowed IP : 0.0.0.0
15. Allowed subnet : 0.0.0.0
<ESC> Back, <ENTER> Refresh
---> 13

Select behavior on DSR input
  1 = None
  2 = Allow TCP connection only by HIGH
    (TCP server or corresponding mode only)
  3 = Open/Close TCP connection
    (Open = HIGH, Close = LOW, TCP client or corresponding mode only)
---->
```

Figure 4-14. Set up the DSR output behavior

4.3.2 Inactivity timeout

The purpose of this parameter is to maintain the TCP connection state as *Closed* or *Listen* in TCP host modes or to close UDP virtual connection in UDP server mode unless there is any data transfer between the serial device and the LS110. If there is no incoming or outgoing data through the serial port during the specified *inactivity timeout* interval, the existing TCP connection or virtual UDP connection will be closed automatically.

If the value of *inactivity timeout* is set to 0 and the host mode is set to one of the TCP modes, the current TCP connection is maintained unless there's a connection close request. Although *inactivity timeout* is disabled, the LS110 will check the connection status between the LS110 and the remote host by sending "keep alive" packets periodically. If the remote host does not answer the packets, it is regarded as a unintentional closed connection. Then, the LS110 will be forced to close the existing TCP connection.

If the value of *inactivity timeout* is set to 0 and the host mode is set to UDP server mode, virtual UDP connection with the first remote host that sends UDP packet to the LS110 will be maintained forever till device is rebooted.

Note:

At least, this value should be set larger than that of *inter-character timeout*. To prevent the unintended loss of data due to the session disconnection, it is highly recommended that this value is set large enough so that the intended data transfer is completed.

```
-----  
Serial port configuration  
-----  
1. Baud rate : 9600  
2. Data bits : 8  
3. Parity : None  
4. Stop bit(s) : 1  
5. Flow control : Hardware  
6. Inter-character timeout : 0  
7. Host mode : TCP Client  
8. Destination IP : 192.168.23.30  
9. Destination port : 7001  
10. Inactivity timeout : 0  
11. Cyclic connection : 0  
12. DTR behavior : Always HIGH  
13. DSR behavior : None  
14. Allowed IP : 0.0.0.0  
15. Allowed subnet : 0.0.0.0  
<ESC> Back, <ENTER> Refresh  
---> 10  
  
Enter inactivity timeout value to disconnect TCP connection in seconds  
      (1 - 3600)Sec , 0 = Unlimited  
--->
```

Figure 4-15. Set up the Inactivity Timeout

4.3.3 Inter-character timeout

This parameter defines the interval that the LS110 fetches the overall serial data from its internal buffer. If there is incoming data through the serial port, the LS110 stores data into the internal buffer. The LS110 transfers data stored in the buffer via TCP/IP, only if the internal buffer is full or if the inter-character time interval reaches to the time specified as *inter-character timeout*.

Optimal inter-character timeout will be different according to your application but at least it must be larger than one character interval within a specified baud rate. For example, assume that the serial port is set to 1200 bps, 8 Data bits, 1 stop bit, and no parity. In this case, the total number of bits to send a character is 10 bits and the time required to transfer one character is

$$10 \text{ (bits)} / 1200 \text{ (bits/s)} * 1000 \text{ (ms/s)} = 8.3 \text{ ms.}$$

Therefore, you have to set *inter-character timeout* to be larger than 8.3 ms. The *inter-character timeout* is specified in milliseconds and must be larger than 10 ms.

If users want to send the series of characters into a packet, serial device attached to the LS110 should send characters without time delay larger than *inter-character timeout* between characters and the total length of data must be smaller than or equal to the LS110 internal buffer size. The buffer size of LS110 is 512 bytes per a port.

```
-----  
Serial port configuration  
-----  
1. Baud rate : 9600  
2. Data bits : 8  
3. Parity : None  
4. Stop bit(s) : 1  
5. Flow control : Hardware  
6. Inter-character timeout : 0  
7. Host mode : TCP Client  
8. Destination IP : 192.168.23.30  
9. Destination port : 7001  
10. Inactivity timeout : 0  
11. Cyclic connection : 0  
12. DTR behavior : Always HIGH  
13. DSR behavior : None  
14. Allowed IP : 0.0.0.0  
15. Allowed subnet : 0.0.0.0  
<ESC> Back, <ENTER> Refresh  
---> 6  
  
Enter Serial inter-character timeout in milliseconds (1 - 10000, 0 for disable)  
--->
```

Figure 4-16. Set up Inter-character timeout

4.3.4 IP Filtering

The LS110 prevents unauthorized access using an IP address based filtering method.

```
-----  
Serial port configuration  
-----  
1. Baud rate : 9600  
2. Data bits : 8  
3. Parity : None  
4. Stop bit(s) : 1  
5. Flow control : Hardware  
6. Inter-character timeout : 0  
7. Host mode : TCP Client  
8. Destination IP : 192.168.23.30  
9. Destination port : 7001  
10. Inactivity timeout : 0  
11. Cyclic connection : 0  
12. DTR behavior : Always HIGH  
13. DSR behavior : None  
14. Allowed IP : 0.0.0.0  
15. Allowed subnet : 0.0.0.0  
<ESC> Back, <ENTER> Refresh  
---> 14  
  
Enter allowed IP  
--->
```

Figure 4-17. Setting IP Filtering (allowed IP)

```
-----  
Serial port configuration  
-----  
1. Baud rate : 9600  
2. Data bits : 8  
3. Parity : None  
4. Stop bit(s) : 1  
5. Flow control : Hardware  
6. Inter-character timeout : 0  
7. Host mode : TCP Client  
8. Destination IP : 192.168.23.30  
9. Destination port : 7001  
10. Inactivity timeout : 0  
11. Cyclic connection : 0  
12. DTR behavior : Always HIGH  
13. DSR behavior : None  
14. Allowed IP : 0.0.0.0  
15. Allowed subnet : 0.0.0.0  
<ESC> Back, <ENTER> Refresh  
---> 15  
  
Enter allowed subnet  
--->
```

Figure 4-18. Setting IP Filtering (allowed subnet)

The users can allow one of the following scenarios by changing allowed IP, allowed subnet parameters.

- Any host cannot access a specific service of the LS110
- Only one host of a specific IP address can access a specific service of the LS110
- Hosts on a specific subnet can access a specific service of the LS110
- Any host can access a specific service of the LS110

The factory default of the filtering feature is “All services and ports are accessible from any host”.

The meanings of each parameter in IP filtering configuration are as follows.

- allowed IP : field to identify allowable network (address)
- allowed subnet : field to identify allowable network (mask)

Case	allowed IP	allowed subnet	Description
Any host cannot access a specific service of the LS110	255.255.255.255	255.255.255.255	except Serial Console, cannot connect to LS110 by Remote Console
Only one host of a specific IP address can access a specific service of the LS110	ex> 192.168.23.12	255.255.255.255	Only one IP can connect to LS110 by Remote console
Hosts on a specific subnet can access a specific service of the LS110	ex> 192.168.23.0	ex> 255.255.255.0	all IPs like 192.168.23.xxx type
Any host can access a specific service of the LS110	0.0.0.0	0.0.0.0	Factory Default values

5. System information

With 'System information' menu, users can see current system parameters in the console. The result is composed of three parts: 'System Information', 'IP Information', and 'Port Information'.

```
-----
Welcome to LS110 Configuration Page
Serial No. :                               MAC Address : 00:01:95:AF:BD:44
F/W REV.  : v0.4.8
IP Mode   : Static IP                       IP Address  : 192.168.23.12
-----

Console#1 (Serial) : Connected
Console#2 (Telnet) : Available
Console#3 (Telnet) : Available
-----

1. IP configuration
2. Serial port configuration
3. System information
4. System administration
5. Save changes
6. Exit without reboot
7. Save and reboot
<ESC> Back, <ENTER> Refresh
----> 3

-----

System Information
-----

Model No.: LS110                               Serial No.:
F/W REV.  : v0.4.8                             MAC Address : 00:01:95:AF:BD:44
-----

IP Information
-----

IP Expiration : N/A                          IP Mode : Static IP
IP Address   : 192.168.23.12                  Subnetmask : 255.255.0.0
Gateway     : 192.168.1.1
Primary DNS  : 168.126.63.1                   Secondary DNS : 168.126.63.2
-----

Port Information
-----

Connection Mode : TCP Server                  Local Port : 6001
Inactivity Timeout : 0 sec                   Inter-Character Timeout : 0 ms
-----

End of system information.
```

Figure 5-1 System information screen

6. System administration

Using 'System administration' menu, allows the user to manage the LS110.

Figure 6-1 The sub menu of 'System administration'.

```
-----  
System administration  
-----  
1. Device name : LS110  
2. Username : root  
3. Password : root  
4. Factory reset  
5. Factory reset without IP settings  
6. Firmware upgrade  
7. Ping  
8. User connection status  
9. Telnet configuration enable/disable : Enable  
<ESC> Back, <ENTER> Refresh  
---->
```

Figure 6-1 System administration

6.1 Device name

Using 'Device name' menu, you can change device name. The usage is as follows.

```
-----  
System administration  
-----  
1. Device name : LS110  
2. Username : root  
3. Password : root  
4. Factory reset  
5. Factory reset without IP settings  
6. Firmware upgrade  
7. Ping  
8. User connection status  
9. Telnet configuration enable/disable : Enable  
<ESC> Back, <ENTER> Refresh  
----> 1  
  
Enter device name (Maximum 30 characters)  
---->
```

Figure 6-2 Device name Screen

6.2 Username

Using 'Username' menu, you can change username. The usage is as follows.

```
-----  
System administration  
-----  
1. Device name : LS110  
2. Username : root  
3. Password : root  
4. Factory reset  
5. Factory reset without IP settings  
6. Firmware upgrade  
7. Ping  
8. User connection status  
9. Telnet configuration enable/disable : Enable  
  <ESC> Back, <ENTER> Refresh  
---> 2  
  
Enter new username : root  
Enter current password : ****  
Username changed.
```

Figure 6-3 Useername Screen

6.3 Password

Using 'Password' menu, you can change login password. The usage is as follows.

```
-----  
System administration  
-----  
1. Device name : LS110  
2. Username : root  
3. Password : root  
4. Factory reset  
5. Factory reset without IP settings  
6. Firmware upgrade  
7. Ping  
8. User connection status  
9. Telnet configuration enable/disable : Enable  
  <ESC> Back, <ENTER> Refresh  
---> 3  
  
Enter new password : ****  
Confirm new password : ****  
Enter current password : ****  
Password changed.
```

Figure 6-4 Password Screen

6.4 Factory reset

With 'Factory reset' menu, users can load factory default parameter values in console. Usage of 'Factory reset' is as follows:

```
-----  
System administration  
-----  
1. Device name : LS110  
2. Username : root  
3. Password : root  
4. Factory reset  
5. Factory reset without IP settings  
6. Firmware upgrade  
7. Ping  
8. User connection status  
9. Telnet configuration enable/disable : Enable  
  <ESC> Back, <ENTER> Refresh  
---> 4  
  
Factory Reset started....  
  
LS110 login :
```

Figure 6-5 Factory reset Screen

6.5 Factory reset without IP settings

With 'Factory reset without IP settings' menu, users can load factory default parameter values without changing IP related settings such as **IP mode / IP address / Subnet mask / Default gateway**. These parameters' values are not affected by this menu.

Usage of 'Factory reset without IP settings' is as follows:

```
-----  
System administration  
-----  
1. Device name : LS110  
2. Username : root  
3. Password : root  
4. Factory reset  
5. Factory reset without IP settings  
6. Firmware upgrade  
7. Ping  
8. User connection status  
9. Telnet configuration enable/disable : Enable  
  <ESC> Back, <ENTER> Refresh  
---> 5  
  
Factory default without IP setting started...  
  
LS110 login :
```

Figure 6-6 Factory reset without IP settings Screen

6.6 Firmware upgrade

With this menu, you can upgrade the firmware of the LS110. Usage of 'Firmware upgrade' is as follows.

Selecting 'Firmware upgrade' in the menu, then wait until following message appears.

```
-----  
System administration  
-----  
1. Device name : LS110  
2. Username : root  
3. Password : root  
4. Factory reset  
5. Factory reset without IP settings  
6. Firmware upgrade  
7. Ping  
8. User connection status  
9. Telnet configuration enable/disable : Enable  
<ESC> Back, <ENTER> Refresh  
---> 6  
  
Preparing for firmware upgrade. Wait a moment...  
Transfer firmware by zmodem using your terminal application.  
**B01ff000005b157
```

Figure 6-7 Firmware upgrade Screen

Execute ZMODEM and select firmware file to upgrade.

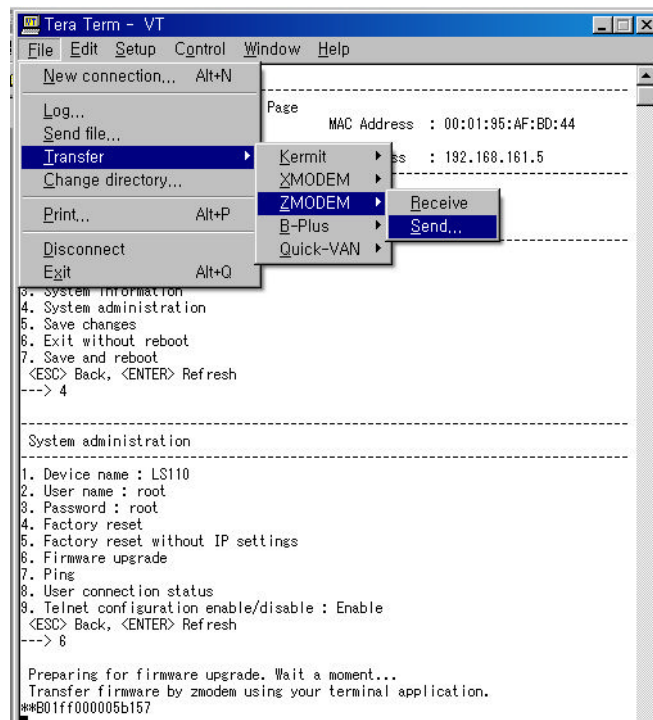

Figure 6-8 Execute ZMODEM

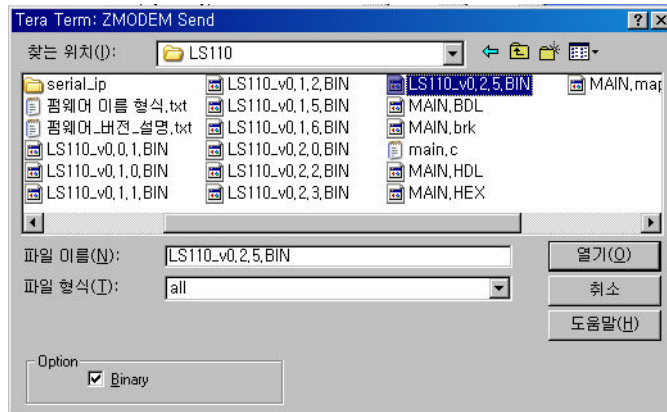

Figure 6-9 Select firmware to upgrade

Select firmware file to upgrade, and firmware upgrade process starts.

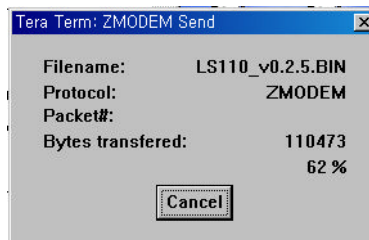

Figure 6-10 firmware upgrade process window

6.7 Ping

With this menu, you can test to see if another network device still exists by using the ping function. Usage of 'ping' is as follows.

```

-----
System administration
-----
1. Device name : LS110
2. Username : root
3. Password : root
4. Factory reset
5. Factory reset without IP settings
6. Firmware upgrade
7. Ping
8. User connection status
9. Telnet configuration enable/disable : Enable
  <ESC> Back, <ENTER> Refresh
  ---> 7

Enter IP Address or Hostname to ping : 192.168.23.1

```

```
to 192.168.23.1 pinging 4 times..  
Receive time = 1ms Sequence num = 0  
Receive time = 1ms Sequence num = 1  
Receive time = 1ms Sequence num = 2  
Receive time = 1ms Sequence num = 3
```

Figure 6-11 ping screen

Type 'ping' on the keyboard and press Enter. Then type IP address to send ping on the keyboard.

6.8 User connection status

'User connection status' menu, allows you to see how many users are logged into the LS110. LS110 allows maximum two users in remote console and one user in serial console. Usage of 'User connection status' is as follows.

```
-----  
System administration  
-----  
1. Device name : LS110  
2. Username : root  
3. Password : root  
4. Factory reset  
5. Factory reset without IP settings  
6. Firmware upgrade  
7. Ping  
8. User connection status  
9. Telnet configuration enable/disable : Enable  
  <ESC> Back, <ENTER> Refresh  
---> 8  
  
-----  
User connection status  
-----  
Console#1 (Serial) : Connected  
Console#2 (Telnet) : Available  
Console#3 (Telnet) : Available  
-----  
End of user connection status.
```

Figure 6-12 User connection status screen

6.9 Telnet configuration enable/disable

Using 'Telnet configuration enable/disable' menu, LS100 can control the connectivity of Remote Console to the LS110.

```
-----  
System administration  
-----  
1. Device name : LS110  
2. Username : root  
3. Password : root  
4. Factory reset  
5. Factory reset without IP settings  
6. Firmware upgrade  
7. Ping  
8. User connection status  
9. Telnet configuration enable/disable : Enable  
  <ESC> Back, <ENTER> Refresh  
---> 9  
  
Select telnet configuration Enable/Disable (1 = Enable, 2 = Disable)  
--->
```

Figure 6-13.setting 'Telnet configuration enable/disable'

Only when the value is 'Enable', Remote Console can connect to LS110.

7. Other Menus

7.1 Save changes

With 'Save changes' menu, current parameter changes are saved to non-volatile memory. Usage of 'Save changes' is as follows

```
-----  
Welcome to LS110 Configuration Page  
Serial No. :                               MAC Address : 00:01:95:AF:BD:44  
F/W REV.  : v0.4.8                          IP Address  : 192.168.161.5  
IP Mode   : Static IP  
-----  
Console#1 (Serial) : Connected  
Console#2 (Telnet) : Available  
Console#3 (Telnet) : Available  
-----  
1. IP configuration  
2. Serial port configuration  
3. System information  
4. System administration  
5. Save changes  
6. Exit without reboot  
7. Save and reboot  
<ESC> Back, <ENTER> Refresh  
----> 5  
Modifications are saved.
```

Figure 7-1 Save changes

Saved changes will be applied if the LS110 is rebooted by 'reboot' command or manual rebooting.

7.2 Exit without reboot

With 'Exit without reboot' menu, current serial or remote console session will be closed. However, if any of the settings are changed, will not be applied until the LS110 is manually rebooted. Usage of 'Exit without reboot' is as follows.

```
-----  
Welcome to LS110 Configuration Page  
Serial No. :                               MAC Address : 00:01:95:AF:BD:44  
F/W REV.  : v0.4.8                          IP Address  : 192.168.161.5  
IP Mode   : Static IP  
-----  
Console#1 (Serial) : Connected  
Console#2 (Telnet) : Available  
Console#3 (Telnet) : Available  
-----  
1. IP configuration  
2. Serial port configuration  
3. System information  
4. System administration
```

```

5. Save changes
6. Exit without reboot
7. Save and reboot
  <ESC> Back, <ENTER> Refresh
---> 6

Exit configuration program... Bye...

LS110 login :

```

Figure 7-2 Exit without reboot

7.3 Save and reboot

With 'Save and reboot' menu, the LS110 will be rebooted immediately. Changed parameter values will be applied when the LS110 is up again. Command usage of 'Save and reboot' is as follows:

```

-----
Welcome to LS110 Configuration Page
Serial No. :                               MAC Address : 00:01:95:AF:BD:44
F/W REV.  : v0.4.8
IP Mode   : Static IP                       IP Address  : 192.168.161.5
-----

Console#1 (Serial) : Connected
Console#2 (Telnet) : Available
Console#3 (Telnet) : Available
-----

1. IP configuration
2. Serial port configuration
3. System information
4. System administration
5. Save changes
6. Exit without reboot
7. Save and reboot
  <ESC> Back, <ENTER> Refresh
---> 7

Rebooting system now...

LS110 login :

```

Figure 7-3 Save and reboot

If you want to apply changed values to system, you must execute both 'save' and 'reboot' process.

Appendix A: Connections

A.1 Ethernet Pin outs

The LS110 uses a standard Ethernet connector, which is a shielded connector compliant with AT&T258 specifications. Table A-1 shows the pin assignment and the wire color.

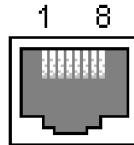

Figure A-1 Pin layout of the RJ45 connector

Table A-1. Pin assignment of the RJ45 connector

Pin	Description	Color
1	Tx+	White with orange
2	Tx-	Orange
3	Rx+	White with green
4	NC	Blue
5	NC	White with blue
6	Rx-	Green
7	NC	White with brown
8	NC	Brown

A.2 Serial Port Pin Outs

The pin assignment of the LS110 DB9 connector is summarized in Table A-2. Each pin has a function according to the serial communication type configuration.

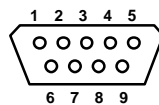

Figure A-2 Pin layout of the DB-9 connector

Table A-2. Pin assignment of the DB-9 connector

Pin	RS232
1	DCD
2	Rx
3	Tx
4	DTR
5	GND
6	DSR
7	RTS
8	CTS
9	-

A.3 Ethernet Wiring Diagram

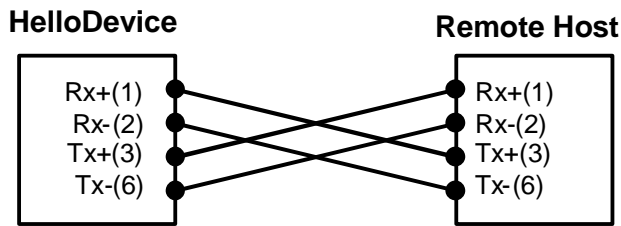

Figure A-3 Ethernet direct connection using crossover ethernet cable

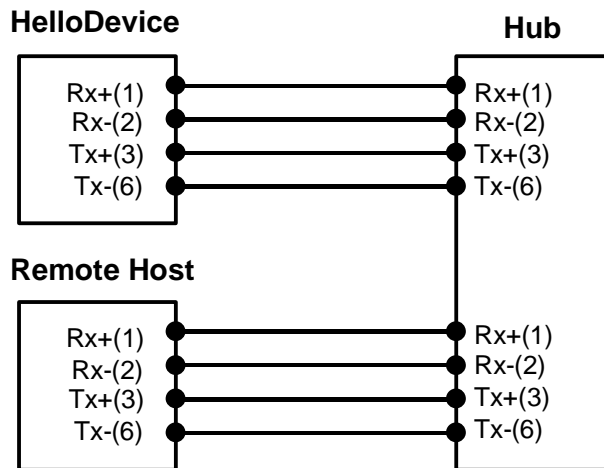

Figure A-4 Ethernet connection using straight through ethernet cable

A.4 Serial Wiring Diagram

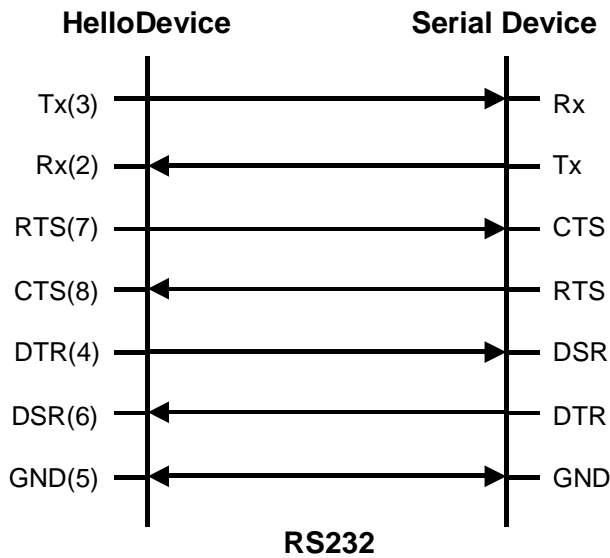

Figure A-5 RS232 wiring diagram

Appendix B: Well-known Port Numbers

The port numbers are divided into three ranges: the Well Known Ports, the Registered Ports, and the Dynamic and/or Private Ports. The Well Known Ports are those from 0 through 1023. The Registered Ports are those from 1024 through 49151. The Dynamic and/or Private Ports are those from 49152 through 65535.

The Well Known Ports are assigned by the IANA, and on most systems, can only be used by system processes or by programs executed by privileged users. Table B-1 shows famous port numbers among the well-known port numbers. For more details, please visit IANA website:

<http://www.iana.org/assignments/port-numbers>

Table B-1 Well-known port numbers

Port number	Protocol	TCP/UDP
21	FTP (File Transfer Protocol)	TCP
22	SSH (Secure SHell)	TCP
23	Telnet	TCP
25	SMTP (Simple Mail Transfer Protocol)	TCP
37	Time	TCP, UDP
39	RLP (Resource Location Protocol)	UDP
49	TACACS, TACACS+	UDP
53	DNS	UDP
67	BOOTP server	UDP
68	BOOTP client	UDP
69	TFTP	UDP
70	Gopher	TCP
79	Finger	TCP
80	HTTP	TCP
110	POP3	TCP
119	NNTP (Network News Transfer Protocol)	TCP
161/162	SNMP	UDP

Appendix C: Troubleshooting

C.1 Power/LED Status Troubleshooting

Problem	Cause	Action
Power LED does not light up	Power cable is not connected	Check power connection
Link LED does not light up	Ethernet cable is not connected	Check Ethernet cable connection
	Invalid Ethernet cable is used	There are two types of Ethernet cables: Straight-through cable and crossover cable. If you are using an Ethernet hub, use straight-through cable. If direct connection between the LS110 and remote host is used, use crossover cable instead.
ACT LED does not blink	Invalid IP configuration	Check IP configuration parameters

C.2 Serial Console Troubleshooting

Problem	Cause	Action
Serial console is not connected	Invalid serial cable	Be sure to use a serial console cable (null-modem cable) for serial console
	Invalid serial port configuration of terminal emulation program	Check serial port configuration of terminal emulation program: 9600 bps, 8 Data bits, No parity, 1 stop bit, Hardware flow control
	Invalid Console/Data switch position	Be sure that Console/Data switch position is Console side.
Serial console is halted for few seconds periodically	IP mode is DHCP, but IP is not assigned	If IP mode is set to DHCP but IP is not actually assigned because of DHCP server failure, serial console is halted for few seconds at every 30 seconds. Change IP mode to the static IP mode
Cannot login to console	Invalid username and/or password	Use valid username and password. If username and/or password are lost, perform factory default reset using factory reset switch. Factory default value of username and password are both 'root'

C.3 Remote Console Troubleshooting

Problem	Cause	Action
Cannot connect to the LS110 using telnet	The LS110 is not assigned valid IP address	Use serial console to assign valid IP address to the LS110
	Someone is using serial console	Exit serial console and retry telnet connection
Cannot login to console	Invalid username and/or password	Use valid username and password. If username and/or password are lost, perform factory default reset using factory reset switch. Factory default value of username and password are both 'root'

C.4 IP Address Troubleshooting

Problem	Cause	Action
Cannot find IP address of the LS110		Use serial console to find IP address
		Use HelloDeviceManager program to probe the LS110 on the network
HelloDeviceManager cannot probe the LS110	The LS110 is not assigned valid IP address	Use serial console to assign valid IP address to the LS110
	HelloDeviceManager and the LS110 are not on the same subnet	Run HelloDeviceManager on the PC that is on the same subnet with the LS110

C.5 DHCP Troubleshooting

Problem	Cause	Action
Cannot lease IP address	DHCP server is not working	Check if DHCP server is working correctly
IP address of the LS110 is changed	DHCP server does not extend lease time	Check if DHCP server is working correctly

C.6 TCP Server Mode Operation Troubleshooting

Problem	Cause	Action
Cannot connect to the LS110	IP configuration of remote host is invalid	Check if IP configuration of the remote host is valid
	Host mode of the LS110 serial port is not TCP server	Change the host mode of the LS110 serial port to TCP server or TCP server/client
	IP address of the LS110 or TCP port number is wrong	Specify valid IP address and TCP port number of the LS110
	DSR option is set but DSR input is not high	Disable DSR option or make DSR input of the LS110 high
	TCP connection with the other host is established already	Close established TCP connection or connect later

C.7 Serial Communication Troubleshooting

Problem	Cause	Action
Serial data are not transferred by TCP/IP immediately	Too large inter-character timeout	Set inter-character timeout with smaller value
Cannot communicate with the LS110	Invalid serial port configuration	Check if serial port configuration of the LS110 are the same with that of the serial device
Invalid data transferred	Invalid serial port configuration	Check if serial port configuration is correct.

Appendix D: Warranty

D.1 GENERAL WARRANTY POLICY

Sena Technologies, Inc. (hereinafter referred to as SENA) warrants that the Product shall conform to and perform in accordance with published technical specifications and the accompanying written materials, and shall be free of defects in materials and workmanship, for the period of time herein indicated, such warranty period commencing upon receipt of the Product.

This warranty is limited to the repair and/or replacement, at SENA's discretion, of defective or non-conforming Product, and SENA shall not be responsible for the failure of the Product to perform specified functions, or any other non-conformance caused by or attributable to: (a) any misapplication or misuse of the Product; (b) failure of Customer to adhere to any of SENA's specifications or instructions; (c) neglect of, abuse of, or accident to, the Product; or (d) any associated or complementary equipment or software not furnished by SENA.

Limited warranty service may be obtained by delivering the Product to SENA or to the international distributor it was purchased through and providing proof of purchase or receipt date. Customer agrees to insure the Product or assume the risk of loss or damage in transit, to prepay shipping charges to SENA, and to use the original shipping container or equivalent.

D.2 LIMITATION OF LIABILITY

EXCEPT AS EXPRESSLY PROVIDED HEREIN, SENA MAKES NO WARRANTY OF ANY KIND, EXPRESSED OR IMPLIED, WITH RESPECT TO ANY EQUIPMENT, PARTS OR SERVICES PROVIDED PURSUANT TO THIS AGREEMENT, INCLUDING BUT NOT LIMITED TO THE IMPLIED WARRANTIES OF MERCHANTABILITY AND FITNESS FOR A PARTICULAR PURPOSE. NEITHER SENA NOR ITS DEALER SHALL BE LIABLE FOR ANY OTHER DAMAGES, INCLUDING BUT NOT LIMITED TO DIRECT, INDIRECT, INCIDENTAL, SPECIAL OR CONSEQUENTIAL DAMAGES, WHETHER IN AN ACTION IN CONTRACT OR TORT (INCLUDING NEGLIGENCE AND STRICT LIABILITY), SUCH AS, BUT NOT LIMITED TO, LOSS OF ANTICIPATED PROFITS OR BENEFITS RESULTING FROM, OR ARISING OUT OF, OR IN CONNECTION WITH THE USE OF FURNISHING OF EQUIPMENT, PARTS OR SERVICES HEREUNDER OR THE PERFORMANCE, USE OR INABILITY TO USE THE SAME, EVEN IF SENA OR ITS DEALER HAS BEEN ADVISED OF THE POSSIBILITY OF SUCH DAMAGES. IN NO EVENT WILL SENA OR ITS DEALERS TOTAL LIABILITY EXCEED THE PRICE PAID FOR THE PRODUCT.

D.3 HARDWARE PRODUCT WARRANTY DETAILS

WARRANTY PERIOD: SENA warranties embedded hardware Product for a period of one (1) year, and external hardware Product for a period of three (3) or five (5) years according to the Product type.

WARRANTY PROCEDURE: Upon return of the hardware Product SENA will, at its option, repair or replace Product at no additional charge, freight prepaid, except as set forth below. Repair parts and replacement Product will be furnished on an exchange basis and will be either reconditioned or new. All replaced Product and parts become the property of SENA. If SENA determines that the Product is not under warranty, it will, at the Customers option, repair the Product using current SENA standard rates for parts and labor, and return the Product at no charge in or out of warranty.

WARRANTY EXCLUSIONS: Damages caused by

- Accidents, falls, objects striking the SENA product,
- Operating the Product in environments that exceed SENA's temperature and humidity specifications,
- Power fluctuations, high voltage discharges,
- Improper grounding, incorrect cabling,
- Misuse, negligence by the customer or any other third party,
- Failure to install or operate the product (s) in accordance to their SENA User Manual,
- Failure caused by improper or inadequate maintenance by the customer or any other third party,
- Floods, lightning, earthquakes,
- Water spills,
- Replacement of parts due to normal wear and tear,
- Hardware has been altered in any way,
- Product that has been exposed to repair attempts by a third party without SENA's written consent,
- Hardware hosting modified SENA Software, or non-SENA Software, unless modifications have been approved by SENA.
- Battery component capacity degradation due to usage, aging, and with some chemistry, lack of maintenance.

D.4 SOFTWARE PRODUCT WARRANTY DETAILS

WARRANTY PERIOD: SENA warranties software Product for a period of one (1) year.

WARRANTY COVERAGE: SENA warranty will be limited to providing a software bug fix or a software patch, at a reasonable time after the user notifies SENA of software non-conformance.

D.5 THIRD-PARTY SOFTWARE PRODUCT WARRANTY DETAILS

The warranty policy of the third-party software is conformed to the policy of the corresponding vendor.