

# **HelloDevice Pro Series**

## **User Guide**

**PS100/PS200/PS400**

**Version 1.0.3**

**2002-07-02**

## **User Guide for the HelloDevice Pro Series**

Version 1.0.3

Firmware version 1.2.x

Printed in Korea

### **Copyright**

Copyright 2002, Sena Technologies, Inc. All rights reserved.

Sena Technologies reserves the right to make changes and improvements to its product without providing notice.

### **Trademark**

HelloDevice™ is a trademark of Sena Technologies, Inc.

Windows® is a registered trademark of Microsoft Corporation.

Ethernet® is a registered trademark of XEROX Corporation.

### **Notice to Users**

When a system failure may cause serious consequences, protecting life and property against such consequences with a backup system or safety device is essential. The user agrees that protection against consequences resulting from system failure is the user's responsibility.

This device is not approved for life-support or medical systems.

Changes or modifications to this device not explicitly approved by Sena Technologies will void the user's authority to operate this device.

### **Technical Support**

Sena Technologies, Inc.

210 Yangjae-dong, Seocho-gu

Seoul 137-130, Korea

Tel: (+82-2) 573-5422

Fax: (+82-2) 573-7710

E-Mail: [support@sena.com](mailto:support@sena.com)

Website: <http://www.sena.com>

# Contents

<b>1: Introduction</b>	<b>6</b>
1.1 Overview .....	6
1.2 Package Check List .....	7
1.3 Product Specification .....	8
1.4 Terminologies and acronyms .....	9
<b>2: Getting Started</b>	<b>11</b>
2.1 Panel Layout .....	11
2.1.1 PS100 Panel Layout .....	11
2.1.2 PS200 Panel Layout .....	12
2.1.3 PS400 Panel Layout .....	13
2.2 Connecting the Hardware .....	15
2.2.1 Connecting the power .....	15
2.2.2 Connecting to the network .....	15
2.2.3 Connecting to the device .....	16
2.3. Accessing Console Port .....	17
2.3.1 Using Serial console .....	17
2.3.2 Using Remote console .....	19
<b>3: IP Address Configuration</b>	<b>21</b>
3.1 Static IP .....	21
3.1.1 Overview .....	21
3.1.2 IP address .....	22
3.1.3 Subnet mask .....	22
3.1.4 Default gateway .....	22
3.1.4 Primary and Secondary DNS .....	23
3.2 DHCP .....	23
3.2.1 Overview .....	23
3.2.2 DHCP setting .....	24
3.3 PPPoE .....	25
3.3.1 Overview .....	25
3.3.2 PPPoE setting .....	26
<b>4: Serial Port Configuration</b>	<b>27</b>
4.1 Host mode configuration .....	29
4.1.1 Overview .....	29
4.1.2 TCP server mode operations .....	31
4.1.3 TCP client mode operations .....	33
4.1.4 TCP server/client mode operations .....	36

4.1.5 UDP tunneling mode operations .....	38
4.1.6 UDP server mode operations .....	39
4.1.7 Modem emulation mode operations .....	40
4.2 UART configuration .....	42
4.2.1 Type .....	43
4.2.2 Baud rate .....	44
4.2.3 Data bits, Stop bits, Parity .....	44
4.2.4 Flow control .....	45
4.2.5 DTR/DSR behavior .....	45
4.3 Cryptography configuration .....	46
4.4 Options .....	47
4.4.1 Inactivity timeout .....	47
4.4.2 Inter-character timeout .....	47
<b>5: Advanced Options Configurations</b> .....	<b>49</b>
5.1 Remote host access control .....	49
5.1.1 Configuration access .....	50
5.1.2 Serial Port access .....	50
5.2 Manual DNS configuration .....	51
5.3 Locating server .....	51
5.3.1 Overview .....	51
5.3.2 Locating server configuration .....	52
5.3.3 Locating server communication protocol .....	53
<b>6: System Status and Log</b> .....	<b>54</b>
6.1 Display system status .....	54
6.2 Display log data .....	55
6.3 Automatic log delivery by email .....	55
<b>7: System administration</b> .....	<b>57</b>
7.1 User name and password .....	57
7.2 Date and time settings .....	58
<b>8: System tools</b> .....	<b>59</b>
8.1 Factory default reset .....	59
8.2 Firmware upgrade .....	59
8.3 Ping test .....	61
8.4 Socket reset .....	61
<b>Appendix A: Connections</b> .....	<b>62</b>
A.1 Ethernet Pin outs .....	62
A.2 Serial Ports Pin Outs .....	62
A.3 Ethernet Wiring Diagram .....	63

A.4 Serial Wiring Diagram .....	63
<b>Appendix B: Well-known port numbers</b>	<b>65</b>
<b>Appendix C: Troubleshooting</b>	<b>66</b>
C.1 Power/LED status troubleshooting .....	66
C.2 Serial console troubleshooting .....	66
C.3 Remote console troubleshooting .....	66
C.4 IP address troubleshooting .....	67
C.5 DHCP troubleshooting .....	67
C.6 TCP server operation troubleshooting .....	67
C.7 Serial communication troubleshooting .....	68

# 1: Introduction

## 1.1 Overview

The HelloDevice Pro Series allows you to network-enable a variety of serial devices that were not originally designed for networking. This capability brings the advantages of remote management and data accessibility to thousands of serial devices over the network.

The PS100 is a versatile single-port serial-Ethernet communication device. The PS200 and PS400 are two-port and four-port serial-Ethernet communication devices respectively expanding the capabilities of the PS100. The HelloDevice Pro Series supports RS232, RS422 or RS485 on each serial port allowing virtually any asynchronous serial device to be accessed over a network.

As for the Internet connectivity, the HelloDevice Pro Series supports open network protocols such as TCP/IP, UDP and PPPoE (PPP-over-Ethernet) allowing serial devices to be accessed over DSL-based broadband network or conventional LAN (Local Area Network) environment.

The HelloDevice Pro Series provides the full-featured management functions such as status monitor, remote reset, error log monitor and firmware upgrade using Telnet and serial console port under the password protection support. In addition, the HelloDevice Pro Series provides IP address filtering function to protect unintentional data streams to be transmitted to the serial device, and static key based 3DES data encryption to promise secure data communication.

The HelloDevice Pro Series was designed to accommodate the unique requirements of the Retail POS, Security, Industrial automation and Medical marketplaces.

Parts of this manual assume the knowledge on concepts of the Internetworking protocols and serial communications. If you are not familiar with these concepts, please refer to the standards or the documentation on each subject.

## **1.2 Package Check List**

- HelloDevice Pro Series external box
- 110V or 230V Power supply adapter
- Serial data cable
- A hardcopy of Quick Start Guide
- CD-ROM including the HelloDevice-IDE, HelloDevice Manager and User Guide

## 1.3 Product Specification

	PS100	PS200	PS400
<b>Serial Interface</b>	1-port RS232/422/485 Male DB9	2-port RS232/422/485 Male DB9	4-port RS232/422/485 Male DB9
	Serial speeds 1200bps to 115Kbps		
	Flow Control: None, Hardware RTS/CTS		
	Signals: RS232 Rx, Tx, RTS, CTS, DTR, DSR, GND RS422 Rx+, Rx-, Tx+, Tx- RS485 Data+, Data-		
<b>Network Interfaces</b>	10 Base-T Ethernet with RJ45 Ethernet connector		
	Supports static and dynamic IP address		
<b>Protocols</b>	ARP, IP/ICMP, TCP, UDP, Telnet, DNS, SMTP, DHCP client, PPPoE		
<b>Security</b>	User ID & Password		
	Data encryption: 3DES		
	IP address filtering		
<b>Management</b>	Telnet or serial console port or HelloDevice Manager		
	System log and statistics Error log storage up to 100 messages Automatic email delivery of error log		
	Full-featured system status display		
<b>Diagnostic LED</b>	Firmware upgrade via serial console or telnet		
	Power Ready 10 Base-T Link, Act Serial Rx/Tx for each serial port		
<b>Power</b>	Supply voltage: 7.5 ~ 30 VDC		
	Supply current: 140mA (nom.)	Supply current: 140mA (nom.)	Supply current: 190mA (nom.)
<b>Environmental</b>	Operating temperature: 0 ~ 55 °C Storage temperature: -4 ~ 66 °C		
<b>Physical properties</b>	Size: 112 mm L 82 mm W 25 mm H (4.4 in x 3.2 in x 1.0 in)	Size: 135 mm L 80 mm W 25 mm H (5.3 in x 3.1 in x 1.0 in)	Size: 230 mm L 153 mm W 30 mm H (9 in x 6 in x 1.2 in)
	Weight: 290g	Weight: 300g	Weight: 920g
<b>Approvals</b>	FCC(A), CE(A), MIC		
<b>Warranty</b>	5-year limited warranty		



## 1.4 Terminologies and acronyms

The Internetworking related terminologies used frequently in this manual are defined clearly to help your better understanding of the HelloDevice Pro Series.

### **MAC address**

On a local area network or other network, the MAC (Media Access Control) address is the computer's unique hardware number. (On an Ethernet LAN, it's the same as your Ethernet address.)

It is a unique 12-digit hardware number, which is composed of 6-digit OUI (Organization Unique Identifier) number and 6-digit hardware identifier number. The HelloDevice Pro Series has the MAC address of 00-01-95-xx-xx-xx, which is labeled on the bottom side of the external box.

### **Host**

A user's computer connected to the network

In Internet protocol specifications, the term "host" means any computer that has full two-way access to other computers on the Internet. A host has a specific "local or host number" that, together with the network number, forms its unique IP address.

### **Session**

A series of interactions between two communication end points that occur during the span of a single connection

Typically, one end point requests a connection with another specified end point and if that end point replies agreeing to the connection, the end points take turns exchanging commands and data ("talking to each other"). The session begins when the connection is established at both ends and terminates when the connection is ended.

### **Client/Server**

Client/server describes the relationship between two computer programs in which one program, the client, makes a service request from another program, the server, which fulfills the request.

A server is a computer program that provides services to other computer programs in the same or other computers, whereas a client is the requesting program or user in a client/server relationship. For example, the user of a Web browser is effectively making client requests for pages from servers all over the Web. The browser itself is a client in its relationship with the computer that is getting and returning the requested HTML file. The computer handling the request and sending back the HTML file is a server.

Table 1-1 Acronym Table

<b>ISP</b>	Internet Service Provider
<b>PC</b>	Personal Computer
<b>NIC</b>	Network Interface Card
<b>MAC</b>	Media Access Control
<b>LAN</b>	Local Area Network
<b>UTP</b>	Unshielded Twisted Pair
<b>ADSL</b>	Asymmetric Digital Subscriber Line
<b>ARP</b>	Address Resolution Protocol
<b>IP</b>	Internet Protocol
<b>ICMP</b>	Internet Control Message Protocol
<b>UDP</b>	User Datagram Protocol
<b>TCP</b>	Transmission Control Protocol
<b>DHCP</b>	Dynamic Host Configuration Protocol
<b>SMTP</b>	Simple Mail Transfer Protocol
<b>FTP</b>	File Transfer Protocol
<b>PPP</b>	Point-To-Point Protocol
<b>PPPoE</b>	Point-To-Point Protocol over Ethernet
<b>HTTP</b>	HyperText Transfer Protocol
<b>DNS</b>	Domain Name Service
<b>SNMP</b>	Simple Network Management Protocol
<b>UART</b>	Universal Asynchronous Receiver/Transmitter
<b>Bps</b>	Bits per second (baud rate)
<b>DCE</b>	Data Communications Equipment
<b>DTE</b>	Data Terminal Equipment
<b>CTS</b>	Clear to Send
<b>DSR</b>	Data Set Ready
<b>DTR</b>	Data Terminal Ready
<b>RTS</b>	Request To Send

## 2: Getting Started

This chapter describes how to set up and configure the HelloDevice Pro Series in the first place.

- 2.1 *Panel Layout* explains the layout of the panel and LED indicators.
- 2.2 *Connecting the Hardware* describes how to connect the power, the network, and the serial device to the HelloDevice Pro Series.
- 2.3 *Accessing Console Port* describes how to access the console port using a serial console at a local site or telnet console at a remote site.

Following items are pre-required to get started.

- One DC power adapter (included in the package).
- One serial data cable for configuration and for connecting the RS-232 serial device.
- One PC with Network Interface Card (hereafter, NIC) and/or one RS232 serial port.
- Terminal emulation program running on the PC
- One Ethernet cable

### 2.1 Panel Layout

#### 2.1.1 PS100 Panel Layout

The PS100 has five LED indicator lamps for status display as shown in Figure 2-1. Two lamps on the upper side indicate statuses of 10 Base-T Ethernet Link and Act. Next lamp indicates statuses of receive and transmit of the serial port for data communication. Next two lamps indicate the system running status and the system power-on status. Table 2-1 describes function of each LED indicator lamp.



Figure 2-1. The panel layout of the PS100

Table 2-1. LED indicator lamps of the PS100

Lamps		Function
10 Base-T	LINK	Turned on to Green if connected to 10 Base-T Ethernet network
	Rx/Tx	Blink whenever there is any activities such as incoming or outgoing packets through the PS100 Ethernet port
Serial port	Rx/Tx	Blink whenever there is any incoming or outgoing data stream through the serial port of the PS100
Status	Ready	Turned on to GREEN if system is running.
	Power	Turned on to RED if power is supplied

### 2.1.2 PS200 Panel Layout

The front panel of the PS200, as shown below in Figure 2-2, has one power switch, one DB9 serial port connector and eight LED indicator lamps for status display. The lamp on the left-hand side indicates the status of the system power-on and system ready. Next two indicate statuses of 10 Base-T Ethernet Link and Act Four other lamps indicate statuses of receive and transmit of each serial port. Table 2-2 describes function of each LED indicator lamp on the panel.

The rear panel of the PS200, also as shown below in Figure 2-2, has one power connector, one RJ45 Ethernet connector for 10 Base-T interface and four DB9 connectors for serial interface.

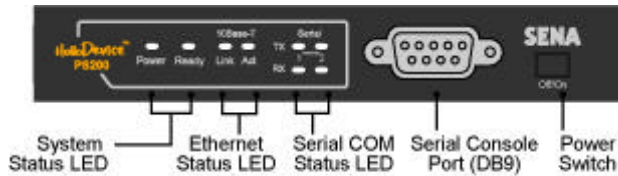

(a) The front panel of the PS200

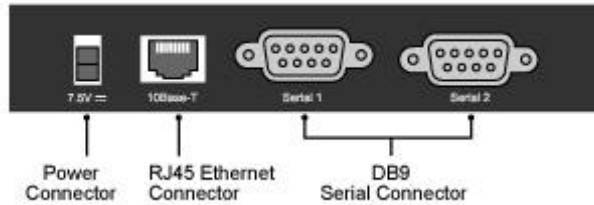

(b) The rear panel of the PS200

Figure 2-2. The panel layout of the PS200

Table 2-2. LED indicator lamps of the PS200

Lamps		Function
System Status LED	Power	Turned on to RED if power is supplied
	Ready	Turned on to Green if system is running
Ethernet Status LED	Link	Turned on to Green if connected to 10 Base-T Ethernet network
	Act	Blink whenever there is any activities such as incoming or outgoing packets through the PS200 Ethernet port
Serial port 1~ 2 Status LED	Rx	Blink whenever there is any incoming data stream through the specified serial port of the PS200
	Tx	Blink whenever there is any outgoing data stream through the specified serial port of the PS200

### 2.1.3 PS400 Panel Layout

The front panel of the PS400 has one power switch, one DB9 serial port connector and twelve LED indicator lamps for status display. The lamp on the left-hand side indicates the status of the system power-on and system ready. Next two lamps indicate statuses of 10 Base-T Ethernet Link and Act. Eight other lamps indicate statuses of receive and transmit of each serial port. Table 2-3 describes function of each LED indicator lamp on the panel.

The rear panel of the PS400 has one power connector, one RJ45 Ethernet connector for 10 Base-T interface and four DB9 connectors for serial interface.

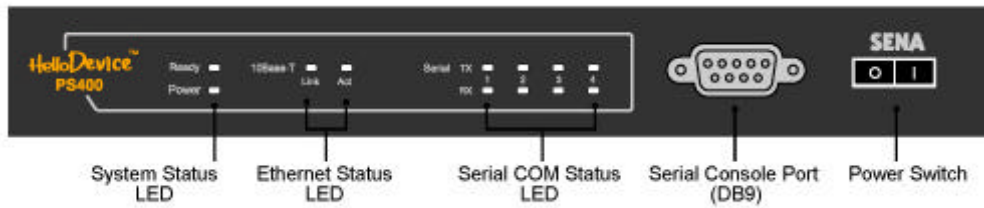

(a) The front panel of the PS400

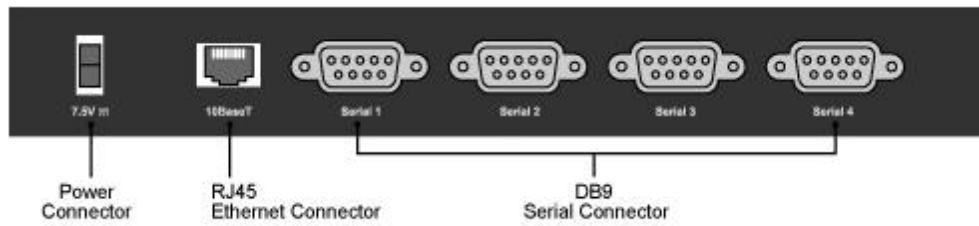

(b) The rear panel of the PS400

Figure 2-3. The panel layout of the PS400

Table 2-3. LED indicator lamps of the PS400

Lamps		Function
System Status LED	Power	Turned on to RED if power is supplied
	Ready	Turned on to Green if system is running
Ethernet Status LED	Link	Turned on to Green if connected to 10 Base-T Ethernet network
	Act	Blink whenever there is any activities such as incoming or outgoing packets through the PS400 Ethernet port
Serial port 1~ 4 Status LED	Rx	Blink whenever there is any incoming data stream through the specified serial port of the PS400
	Tx	Blink whenever there is any outgoing data stream through the specified serial port of the PS400

## 2.2 Connecting the Hardware

This section describes how to connect the HelloDevice Pro Series to serial devices for the first time test.

- Connect the power to the HelloDevice Pro Series
- Connect the Ethernet cable between the HelloDevice Pro Series and Ethernet hub or switch
- Connect the serial data cable between the HelloDevice Pro Series and serial device(s)

### 2.2.1 Connecting the power

Connect the power jack to the HelloDevice Pro Series power jack using DC power adapter included in the package. If the power is properly supplied, the [Power] lamp will maintain solid red.

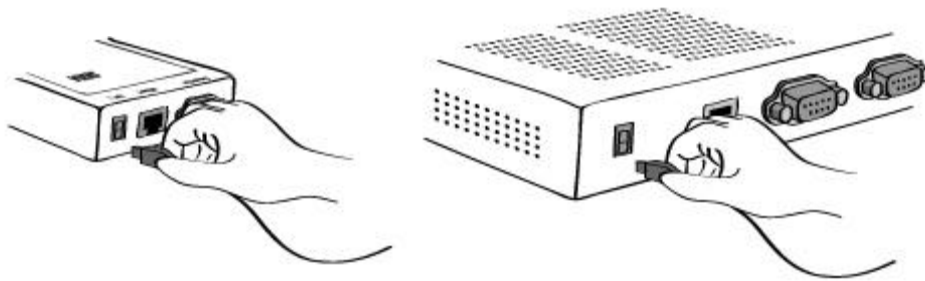

(a) Connecting the power to the PS100      (b) Connecting the power to the PS200/400

Figure 2-4. Connecting the power to the HelloDevice Pro Series

### 2.2.2 Connecting to the network

Connect the one end of the Ethernet cable to the HelloDevice Pro Series 10Base-T port and the other to the Ethernet network. If the cable is properly hooked up, the HelloDevice Pro Series will have a valid connection to the Ethernet network by indicating:

- [Link] lamp maintains solid green
- [Act] lamp continuously blinks to indicate the incoming/outgoing Ethernet packets

If any of the above does not happen, the HelloDevice Pro Series is not properly connected to the Ethernet network.

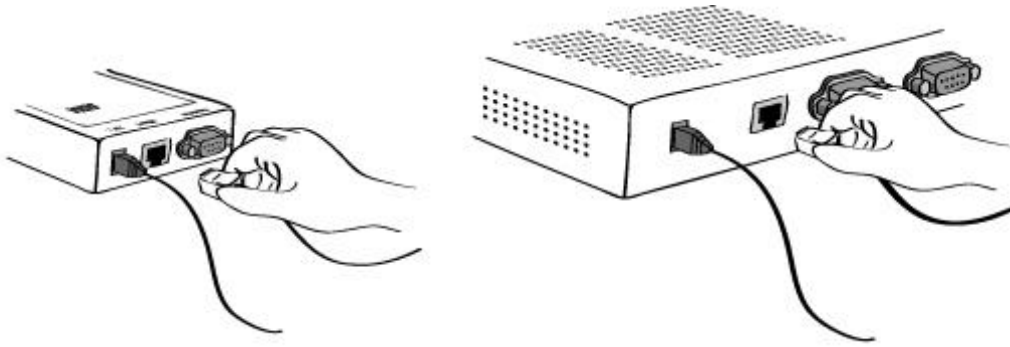

(a) Connecting a network cable to the PS100 (b) Connecting a network cable to the PS200/400  
 Figure 2-5. Connecting a network cable to the HelloDevice Pro Series

### 2.2.3 Connecting to the device

Connect the serial data cable between the HelloDevice Pro Series and the serial device. If necessary, supply the power to the serial device attached to the HelloDevice Pro Series.

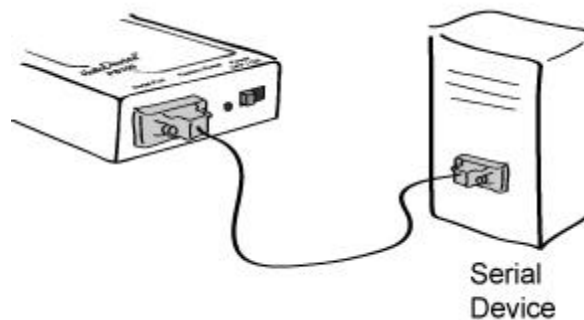

(a) Connecting a serial device to the PS100

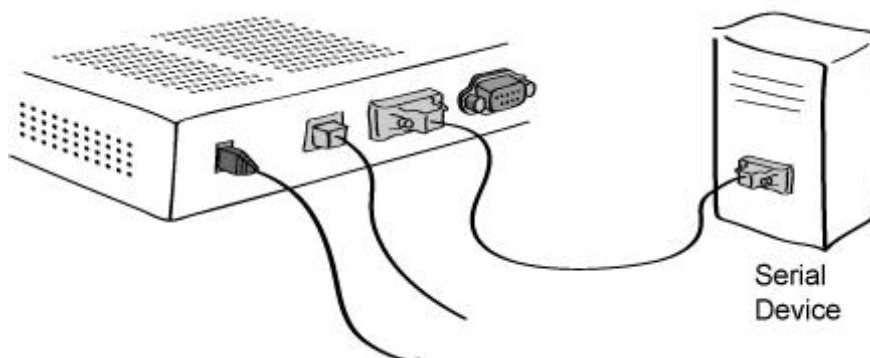

(b) Connecting a serial device to the PS200/400

Figure 2-6. Connecting a serial device to the HelloDevice Pro Series



## 2.3. Accessing Console Port

There are two ways to access console port of the HelloDevice Pro Series depending on whether the user is located at a local site or a remote site.

- Serial console:

Local users can connect directly to the serial console port of the HelloDevice Pro Series using serial console cable (null-modem cable).

- Remote console:

Remote users can make a telnet connection to the remote console port (port 23) of the HelloDevice Pro Series via TCP/IP network.

Both methods require the user to log into the HelloDevice Pro Series in order to continue.

### 2.3.1 Using Serial console

- 1) Connect the one end of the serial console cable to the console port on the HelloDevice Pro Series.

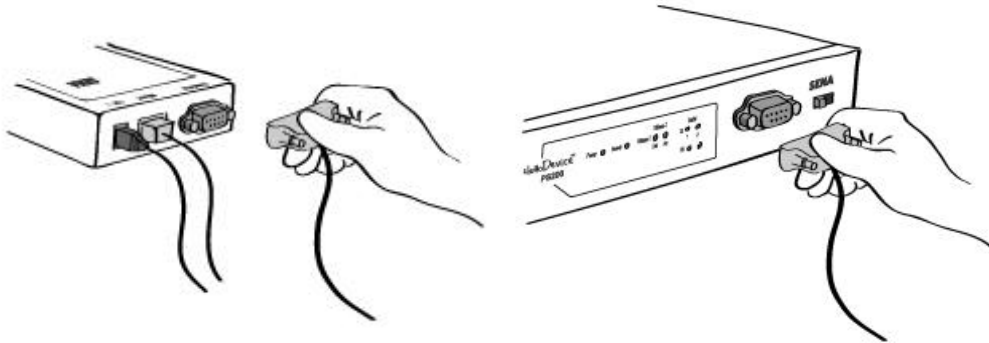

(a) Connecting a serial console cable to the PS100 (b) Connecting a serial console cable to the PS200

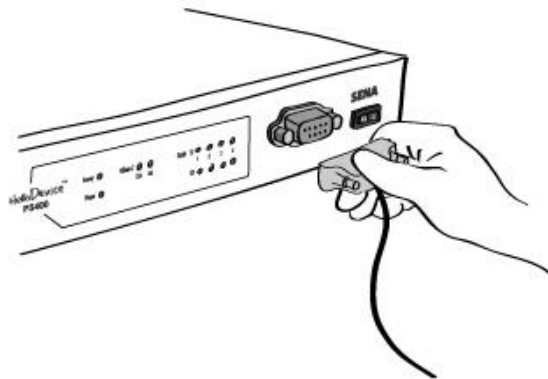

(c) Connecting a serial console cable to the PS400

Figure 2-7. Connecting a serial console cable to the PS200

- 2) Connect the other end of the cable to the serial port of user's computer.
- 3) Run a terminal emulator program such as HyperTerminal. Set up the serial configuration parameters of the terminal emulation program as follows:  
**9600 Baud rate, Data bits 8, Parity None, Stop bits 1, Hardware flow control (RTS/CTS)**
- 4) Press [ENTER] key.
- 5) Type the user name and password to log into the HelloDevice Pro Series. A factory default setting of the user name and password are both **admin**.

```
login : admin
Password : *****
```

- 6) If the user logged into the HelloDevice Pro Series successfully, the main menu screen will appear on the computer.

From the main menu screen, shown below in Figure 2-8, users can select the menu item for the configuration of the HelloDevice Pro Series parameters by typing the menu number and pressing [ENTER] key. In the submenu screen, users can configure the required parameters guided by online comments. All the parameters are stored into the non-volatile memory space of the HelloDevice Pro Series, and it will not be stored until users select menu *7.Save changes*. When users are finished with the configuration, the system needs to be rebooted by selecting the menu *9.Exit and reboot*. All the configuration changes will be effective after the reboot.

```
-----
Welcome to PS-400 configuration page
Current time: 2002/05/04 14:13:25
Serial No.   : PS200-020200028  MAC Address: 00-01-95-04-13-80
F/W REV.    : V1.2.12          UP time   : 0 Days 02:26:00
IP mode     : DHCP            IP Address: 192.168.0.152
-----
Console#1 (Serial) : Connected
Console#2 (Telnet) : Available (NULL)
Console#3 (Telnet) : Available (NULL)
Console#4 (Telnet) : Available (NULL)
-----
Select menu
1. IP Configuration
2. Serial port configuration
3. System Status & log
4. System administration
5. Advanced options
6. System tools
7. Save changes
8. Exit without reboot
9. Exit and reboot
<ESC> Back, <ENTER> Refresh
-----
```

Figure 2-8. The main menu screen (PS400)

## 2.3.2 Using Remote console

The static IP address of the HelloDevice Pro Series must be assigned before users can access the remote console port (See **IP Address Configuration** in chapter 3 for details). Remote console access function is optional, and can be disabled in the remote access option on the menu (See **Remote Host Access Control** in section 5.1 for details). This is useful when system administrator does not want others to modify the existing configuration. Only one user can log into the remote console port of the HelloDevice Pro Series at the same time. The port number for the remote console is 23, which is a TCP port number assigned for Telnet.

Up to three remote console sessions can be established simultaneously using telnet. When they are established, the first console session has a right to change the parameter values while others have a right to read parameter values only. If the serial console is established, all of the remote telnet consoles do not have a right to update the parameter values.

- 1) Run a telnet program or a program that supports telnet functions such as TeraTerm-Pro or HyperTerminal. The target IP address and the port number should be those of the HelloDevice Pro Series. If required, specify the port number as 23. Type the following command in the command line interface of your computer.

```
telnet 192.168.1.254
```

Or run a telnet program with parameters as follows.

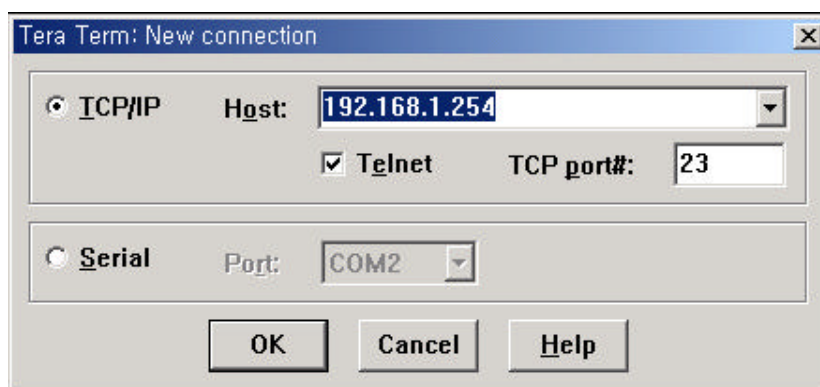

*Figure 2-9 Telnet program set up example*

- 2) The user has to log into the HelloDevice Pro Series. Type the user name and password. A factory default setting of the user name and password are both **admin**.

```

Welcome to PS-400 Configuration
Console#1 (Serial) : Not Connected
Console#2 (Telnet) : Available (NULL)
Console#3 (Telnet) : Available (NULL)
Console#4 (Telnet) : Established (192.168.0.16)

login : admin
Password : *****

```

Figure 2-10. Users' logging into the HelloDevice Pro Series (PS400)

- 3) If the user logged into the HelloDevice Pro Series successfully, the same main menu screen as the one of serial console will be displayed. The user can select the menu by typing the menu number and then pressing [ENTER] key. In the corresponding menu screen, the user can configure the required parameters.
- 4) If serial console or the other remote consoles are connected already, the new console will be established as read-only mode. Figure 2-11 shows the screen display of a read-only mode console.

```

Welcome to PS-400 Configuration
Console#1 (Serial) : Not Connected
Console#2 (Telnet) : Available (NULL)
Console#3 (Telnet) : Established (192.168.0.16) : Read-only
Console#4 (Telnet) : Established (192.168.0.16)
This Console(#3) is Read-Only

login : admin
Password : *****

-----
Welcome to PS-400 configuration page
Current time: 2002/05/04 14:19:47
Serial No.   : PS200-020200028  MAC Address: 00-01-95-04-13-80
F/W REV.    : V1.2.12           UP time   : 0 Days 02:32:22
IP mode     : DHCP              IP Address: 192.168.0.152
-----
Console#1 (Serial) : Not Connected
Console#2 (Telnet) : Available (NULL)
Console#3 (Telnet) : Established (192.168.0.16) : Read-only
Console#4 (Telnet) : Established (192.168.0.16)
This Console(#3) is Read-Only
-----
Select menu
1. IP Configuration
2. Serial port configuration
3. System Status & log
4. System administration
5. Advanced options
6. System tools
7. Save changes
8. Exit without reboot
9. Exit and reboot
<ESC> Back, <ENTER> Refresh
----->

```

Figure 2-11. Screen display of a read-only mode console (PS400)

## 3: IP Address Configuration

A valid IP address of the HelloDevice Pro Series needs to be assigned before it starts to work in the user's network environment. A network system administrator may provide the user with this IP address setting information for the network. The IP address must be unique within the network. Otherwise, the HelloDevice Pro Series will not have a valid connection to the network.

Users can choose the desired IP mode out of the three IP operating modes, i.e., **Static IP, DHCP, and PPPoE**, on the IP Configuration Screen of console interface. The factory default IP mode is **DHCP** mode. Table 3-1 shows the parameter items for **IP Configuration** menu.

Table 3-1. Hierarchical view of the IP Configuration menu items

<b>Static IP</b>	IP mode
	IP address
	Subnet mask
	Default gateway
	Primary DNS/ Secondary DNS
<b>DHCP</b>	IP mode
<b>PPPoE</b>	IP mode
	PPPoE User name/ Password

### 3.1 Static IP

#### 3.1.1 Overview

In the **Static IP** mode, users have to manually specify all the parameters such as IP addresses of the HelloDevice Pro Series, the gateway computer and the domain name server computers, and the network subnet mask. The HelloDevice Pro Series tries to locate such information whenever it boots up.

The user interface for **Static IP configuration** is shown below in Figure 3-1. Users can select menu by typing the menu number and then pressing [ENTER] key.

```
-----  
IP configuration  
-----  
Select menu:  
1. IP mode: static IP  
2. IP address: 192.168.1.1  
3. Subnet mask: 255.255.255.0  
4. Default gateway: 192.168.1.254  
5. Primary DNS: 210.106.255.188  
6. Secondary DNS: 210.106.255.189  
<ESC> Back, <ENTER> Refresh  
--->
```

Figure 3-1. Static IP configuration screen

### 3.1.2 IP address

In the **Static IP** mode, the IP address is an identification number assigned to a computer as a permanent address on the network. Computers use IP addresses to identify and talk to each other on the network. Choose the proper IP address which is unique and valid on the network environment.

```
---> 2  
Enter IP address: 192.168.1.100[ENTER]
```

*Figure 3-2. Setting the IP address in Static IP mode*

#### **Note:**

The IP address in the form of 192.168.1.x is private in a sense that they are not assigned by an ISP. Application of the HelloDevice Pro Series may require sending data back and forth over a public network, such as the Internet. In this case, it is required to assign a valid public IP address. The public IP address is generally purchased or leased from a local ISP.

### 3.1.3 Subnet mask

A subnet represents all the network hosts at one geographic location, in one building, or on the same local area network. When there is any outgoing packet over the network, the HelloDevice Pro Series will check whether the desired TCP/IP host specified in the packet is on the local network segment with the help of the subnet mask. If the address is proven to be on the same network segment as the HelloDevice Pro Series, the connection is established directly from the HelloDevice Pro Series. Otherwise, the connection is established through the given default gateway.

```
---> 3  
Enter subnet mask: 255.255.255.0[ENTER]
```

*Figure 3-3. Setting the subnet mask in Static IP mode*

### 3.1.4 Default gateway

A gateway is a network point that acts as an entrance to another network. Usually, the computers that control traffic within the network or at the local Internet service provider are gateway nodes. The HelloDevice Pro Series needs to know the IP address of the default gateway computer in order to

communicate with the hosts outside the local network environment. For correct information on the gateway IP address, please refer to the network administrator.

```
---> 4  
Enter default gateway: 192.168.1.1[ENTER]
```

*Figure 3-4. Setting the default gateway in Static IP mode*

### 3.1.4 Primary and Secondary DNS

When users want to visit certain website, the computer asks a Domain Name System (DNS) server for the correct IP address of the web site, and the computer uses the answer to connect to the web server. DNS is the way that Internet domain names are identified and translated into IP addresses. Domain name is the form of alphanumeric name such as **sena.com** and it is usually easier to remember. A DNS server is a host that can translate such text-based domain names into the numeric IP addresses for TCP/IP connection.

In order to use this DNS feature of the HelloDevice Pro Series, users need to set the IP address of this DNS server to be able to access the host with the domain name. The HelloDevice Pro Series provides the way to configure IP addresses of DNS servers, i.e. **Primary DNS server, Secondary DNS server**. A secondary DNS server is specified for use when the primary DNS server is unavailable.

```
---> 5 (or 6)  
Enter primary (or secondary) DNS server: 211.112.43.133[ENTER]
```

*Figure 3-5. Setting the DNS servers in Static IP mode*

## 3.2 DHCP

### 3.2.1 Overview

Dynamic Host Configuration Protocol (DHCP) is a communications protocol that lets network administrators manage and automate the assignment of IP addresses centrally in an organization's network. DHCP lets a network administrator supervise and distribute IP addresses from a central point and automatically send a new IP address when a computer is plugged into a different place in the network.

As described in the section 3.1, the IP address must be entered manually at each computer in Static IP mode and, if computers move to another location in another part of the network, a new IP address must be entered. Meanwhile, all the parameters including the IP address, subnet mask, gateway, DNS

servers will be automatically configured when the IP address is assigned in DHCP mode. DHCP uses the concept of a "lease" or amount of time for which a given IP address will be valid for a computer. All the parameters required to assign an IP address are configured on DHCP server side, and each DHCP client computer receives this information when the IP address is provided at its boot-up.

To obtain an IP address, the HelloDevice Pro Series sends a corresponding DHCP request as a broadcast over the network after each reset. The reply generated by the DHCP server contains the IP address as well as the subnet mask, gateway address, DNS servers and the lease time. The HelloDevice Pro Series immediately places this information in its non-volatile memory. If the operating time reaches the lease time, the HelloDevice Pro Series will request the DHCP server for renewal of its lease time. If the DHCP server approves extending the lease, the HelloDevice Pro Series can continue to work with the current IP address. Otherwise, the HelloDevice Pro Series will start the procedure to request a new IP address to the DHCP server.

**Note:**

In DHCP mode, all the network-related parameters for the HelloDevice Pro Series are supposed to be configured automatically. In case that automatic configuration of DNS server fails, it can be configured manually in *Manual DNS Configuration* menu. (See *Manual DNS Configuration* in section 5.3 for further information).

A DHCP sever assigns IP addresses dynamically from an IP address pool, which is managed by the network administrator. This means DHCP client, i.e. the HelloDevice Pro Series, receives a different IP address each time it boots up. To prevent the case that users do not know the IP address of the HelloDevice Pro Series in such environments, its IP address should be reserved on the DHCP server side. In order to reserve the IP address in the DHCP network, the administrator needs the MAC address of the HelloDevice Pro Series found on the label sticker at the bottom of the HelloDevice Pro Series:

MAC=00:01:95:04:0c:a1

### 3.2.2 DHCP setting

```
-----  
IP configuration  
-----  
Select menu:  
IP mode: DHCP  
<ESC> Back, <ENTER> Refresh  
---> 1  
Select mode (1 = Static IP, 2 = DHCP, 3 = PPPoE)  
---> 2
```

Figure 3-6. Setting DHCP mode



## 3.3 PPPoE

### 3.3.1 Overview

PPPoE (PPP over Ethernet) is a specification for connecting multiple computer users on an Ethernet local area network to a remote site through common customer premises equipment, which is the telephone company's term for a modem and similar devices. PPPoE can be used to have an office or building-full of users share ADSL, cable modem, or wireless connection to the Internet. Usually, it is used in broadband Internet access such as ADSL.

To make the HelloDevice Pro Series work in PPPoE mode, users should have a PPPoE account and the equipments for PPPoE access such as an ADSL modem. Since the HelloDevice Pro Series provides the PPPoE protocol, it can access the remote host on the Internet over ADSL connection. It is required to set up the user name and password of the PPPoE account for the HelloDevice Pro Series.

If the IP mode is set to PPPoE, The HelloDevice Pro Series negotiates the PPPoE connection with PPPoE server whenever it boots up. During the negotiation, it receives the information required for Internet connection such as IP address, gateway, subnet mask and DNS servers. If the connection is established, the HelloDevice Pro Series tries to maintain the connection as long as possible. If the disconnection is detected, the HelloDevice Pro Series will attempt to make a new PPPoE connection by requesting the new connection.

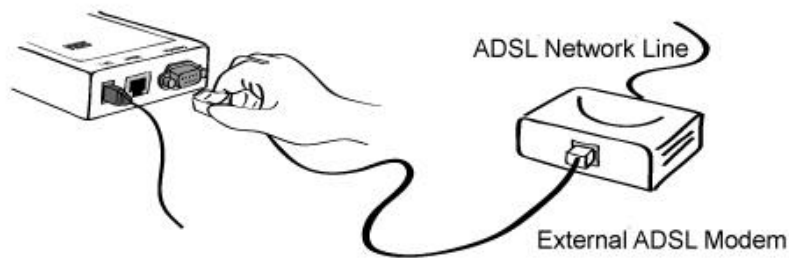

(a) Installation of the PS100 with ADSL connection

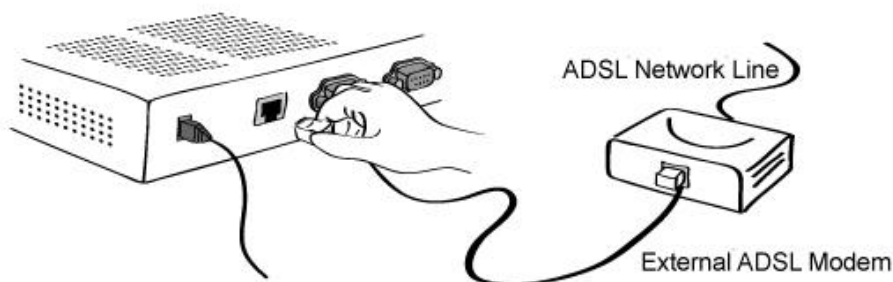

(b) Installation of the PS200/400 with ADSL connection

Figure 3-7. Installation of the HelloDevice Pro Series with ADSL connection

### 3.3.2 PPPoE setting

To make the HelloDevice Pro Series work in PPPoE mode, users need to configure the PPPoE username and password for their ADSL account.

```
-----  
IP configuration  
-----  
Select menu  
1. IP mode : PPPoE  
2. Change PPPoE username : whoever  
3. Change PPPoE user password : pppoepwd  
  <ESC> Back, <ENTER> Refresh  
-----> 2  
Enter user name : pppoeuser  
  
-----  
IP configuration  
-----  
Select menu  
1. IP mode : PPPoE  
2. Change PPPoE username : pppoeuser  
3. Change PPPoE user password : pppoepwd  
  <ESC> Back, <ENTER> Refresh  
-----> 3  
Enter password : pppoepassword  
  
-----  
IP configuration  
-----  
Select menu  
1. IP mode : PPPoE  
2. Change PPPoE username : pppoeuser  
3. Change PPPoE user password : pppoepassword  
  <ESC> Back, <ENTER> Refresh  
----->
```

*Figure 3-8. Set up username and password for PPPoE account*

## 4: Serial Port Configuration

Serial port configuration screen can be reached through menu 2 in the main menu screen. Serial port configuration menu contains four groups of the parameters such as Host mode configuration, UART configuration, Cryptography configuration and additional options for serial data communication. Users need to set up all those parameters for each serial port considering the serial device that will be hooked up to the serial port.

- Host mode: Host mode related parameters for each serial port
- UART: Serial communication parameters such as baud rate, parity, data bits, stop bits, etc.
- Cryptography: Encryption related parameters for data communication
- Options: Timer related parameters for data communication

The following picture shows the initial screen of Serial Port configuration menu of the PS400. With the PS100, only port#1 settings menu will be shown, while with the PS200, port#1 and port#2 settings menu will be shown.

```
-----  
Serial configuration  
-----  
Port# Mode  Port  Destination          Type  Settings  Flow  
1   TCP s   6000  N/A                  RS232  9600-N-8-1  RTS/CTS  
2   TCP s   6001  N/A                  RS232  9600-N-8-1  RTS/CTS  
3   TCP s   6002  N/A                  RS232  9600-N-8-1  RTS/CTS  
4   TCP s   6003  N/A                  RS232  9600-N-8-1  RTS/CTS  
Select menu  
1. port#1 settings  
2. port#2 settings  
3. port#3 settings  
4. port#4 settings  
  <ESC> Back, <ENTER> Refresh  
----->
```

Figure 4-1. Initial screen for serial port configuration (PS400)

If users select the desired serial port number, the following screen of four menu groups for the selected serial port will be displayed. Table 4-1 shows a hierarchical view of all the menu items of serial port configuration.

```

-----
Serial configuration --> port #1
-----

Select menu
1. Host mode configuration
2. UART Configuration
3. Cryptography Configuration
4. Option
<ESC> Back, <ENTER> Refresh
----->

```

Figure 4-2. Initial screen for each serial port configuration

Table 4-1. Hierarchical view of the Serial Port Configuration menu items

Host mode	TCP Server	Host Mode		
		Local Port		
	TCP Client	Host Mode		
		Destination IP/Port		
		Cyclic Connection	Enable/Disable	
		Interval		
	TCP Server/Client	Host Mode		
		Local Port		
		Destination IP/Port		
		Cyclic Connection	Enable/Disable	
	Interval			
	UDP Tunneling	Host Mode		
Local Port				
Destination IP/Port				
UDP Server	Host Mode			
	Local Port			
Modem Emulation	Host Mode			
UART	RS232	Type		
		Baud rate	1200/2400/4800/9600 19200/38400/57600/115200	
		Data bits	7/8	
		Parity	None/Even/Odd	
		Stop bits	1/2	
		Flow control	None, Hardware (RTS/CTS)	
		DTR behavior	Always HIGH	
			Always LOW	
			Show TCP connection	
		DSR behavior	None	
	Open/Close TCP connection			
	Accept TCP connection only by HIGH			
	RS485 echo	TYPE, Baud rate, Data bits, Parity, Stop bits		
RS485 non-echo	TYPE, Baud rate, Data bits, Parity, Stop bits			
RS422	TYPE, Baud rate, Data bits, Parity, Stop bits			
Cryptography	None	Method		
	3DES	Method		
		Key string		
Options	Inactivity timeout			
	Inter-character timeout			

## 4.1 Host mode configuration

### 4.1.1 Overview

Host mode represents the operating session mode of the HelloDevice Pro Series. Several host modes are available for the data communication between serial devices and remote hosts. Since TCP is connection-oriented protocol, server, client, server/client modes are provided. Other than those TCP based modes, UDP mode is provided for connectionless communication. Modem emulation mode supports several basic AT commands for TCP session control so that users can change the host mode on-line from the serial device by using AT commands. Table 4-2 shows the brief description of the host modes.

Table 4-2. The HelloDevice Pro Series TCP/IP session modes

Mode	Description
<b>TCP server</b>	Select this mode, when users want the HelloDevice Pro Series to operate as a TCP server. The HelloDevice Pro Series stands by until there is any TCP connection request. If TCP connection is not already established at that time, the HelloDevice Pro Series accepts the request and the session is established. In the established state, it transmits the data through the corresponding serial port if there is any data from the remote host. Since the HelloDevice Pro Series supports only one TCP session per serial port, the additional TCP connection request will be rejected if already established. This mode is useful when users want to send data to the serial device at any time they want.
<b>TCP client</b>	Select this mode, when users want the HelloDevice Pro Series to operate as a TCP client. When the serial device sends data or pre-defined timer is expired, the HelloDevice Pro Series tries to establish a TCP connection to a remote server through its TCP port. If a TCP session is established between them, the HelloDevice Pro Series will send data to the server. If there's any data from the server during the session, it will also send the data through the serial port. However, if the HelloDevice Pro Series failed to connect to the remote server, the data from the serial port will be discarded. This is useful when the serial device initiates sending data such as data gathering application.
<b>TCP server/client</b>	If you are not sure which mode to choose, select this mode since it will be applied in most applications. In this mode, the HelloDevice Pro Series operates as TCP server AND client. If the connection is not established, it will accept all incoming connection and connect to the remote host if there are any data from the serial device. Otherwise, it will send data back and forth. In summary, the HelloDevice Pro Series will work as if it is virtually connected to the remote host.
<b>UDP tunneling</b>	The UDP tunneling mode operation is similar to that of <i>TCP server/client</i> mode except that it is based on UDP protocol and only one pre-defined remote host is able to communicate with the HelloDevice Pro Series.
<b>UDP server</b>	While UDP tunneling mode allows only one remote host for UDP communications, UDP server mode allows any remote host to access the HelloDevice Pro Series. In this mode, the HelloDevice Pro Series gets the information on the remote host from the latest incoming datagram information.
<b>Modem emulation</b>	Select this mode when the serial device already supports modem AT commands or users want to perform the session control by using AT commands. Only TCP session is supported.

A factory default host mode is **TCP Server**, and users can select the mode by using the menu, *Serial Port Configuration-host mode Configuration-Host mode*.

```
-----  
serial configuration -->port#1 --> TCP/IP  
-----  
Select menu  
1. Host mode : TCP Server  
2. Local port : 6000  
<ESC> Back, <ENTER> Refresh  
-----> 1  
  
Select host mode  
1 = TCP Server, 2 = TCP Client, 3 = TCP Server / Client  
4 = UDP Server / Client, 5 = modem emulation  
----->
```

Figure 4-3. Set up Host Mode

For easier understanding of TCP modes, a simplified **State Transition Diagram** is often used. And too help users understand the diagram, the TCP state of the HelloDevice Pro Series is briefly described as follows.

**- Listen**

It represents “a waiting for a connection request from any remote host”. It is a default start-up mode when it is set as *TCP server* mode. This state is valid only in *TCP server* mode operation.

**- Closed**

It means “No connection state at all”. If the data transfer is completed, the state is changed to this state if one of the host requests disconnection request. If it is in *TCP server* mode, the state is automatically changed to [Listen] mode. It is a default start-up mode when it is set as *TCP client* mode or *TCP server/client* mode.

**- Sync-Received**

In *TCP server* mode, the state will be changed from [Listen] to [Sync-Received], if any remote host sends connection request. If the HelloDevice Pro Series accepts the request, the state will be changed into [Established]. This state is not valid in *TCP client* mode.

**- Sync-Sent**

If the HelloDevice Pro Series sends a connection request to a remote host, the state is changed from [Closed] to [Sync-Sent]. This state is maintained until the remote host accepts the connection request. This state is valid only in *TCP client* mode.

**- Established**

It represents “an open connection”. If one of the hosts accepts a connection request from the other host, the connection is opened and state is changed into [Established].

#### - Data

When it is in [Established] state, data from a host will be transferred to the other one. For easier understanding of the TCP session operation, we called the state as [Data] state when actual data transfer is performed. Actually, the [Data] mode is a part of [Established] state as is described in the RFC 793 [Transmission Control Protocol]. This is a normal state for the data transfer phase of the connection.

### 4.1.2 TCP server mode operations

The HelloDevice Pro Series works as a TCP server, and the default TCP state is [Listen] in this mode. The HelloDevice Pro Series supports only one TCP socket connection per one serial port. If a connection is currently established, the additional connection requests will be rejected. The remote host will be either Ethernet-Serial communication devices acting as a TCP client or a socket program acting as a TCP client running on users' PC.

#### 1) Typical State Transition

[Listen] --> [Sync-Received] --> [Established] --> [Data] --> [Closed] --> [Listen]

At start-up, an initial TCP state is [Listen]. If there is any incoming TCP connection request, the state will be changed into [Sync-Received], then [Established], which means a session is opened. For a while, data will be transferred between the hosts. This is the [Data] state. The session will be disconnected due to the request of one of them, which is [Closed] state. And then, the state is automatically changed to its original state, [Listen].

#### 2) Operations

##### Serial data transfer

When a session has been established, the HelloDevice Pro Series reads the data from the serial port buffer till internal serial buffer is full or inter-character time interval reaches the time specified as *inter-character timeout* value. Then, it transfers the data to the IP address (or domain name) of the remote host (See *Options* in section 4.4 for more details on *inter-character timeout*). If there's no remote host connected to the HelloDevice Pro Series, all the incoming data from the serial port are discarded.

##### Session disconnection

The connected session will be disconnected when the remote host sends disconnection request or when no data transfer activity is found through the serial port for a certain amount of time, which is "*Inactivity timeout*" (See *Options* in section 4.4 for details on *Inactivity timeout*).

### IP address filtering

The HelloDevice Pro Series will not accept the incoming connection request from the remote hosts which are not in the host list (See *Remote Host Access Control* in section 5.1 for details).

Figure 4-4 shows the State Transition Diagram of the session operations in *TCP server* mode.

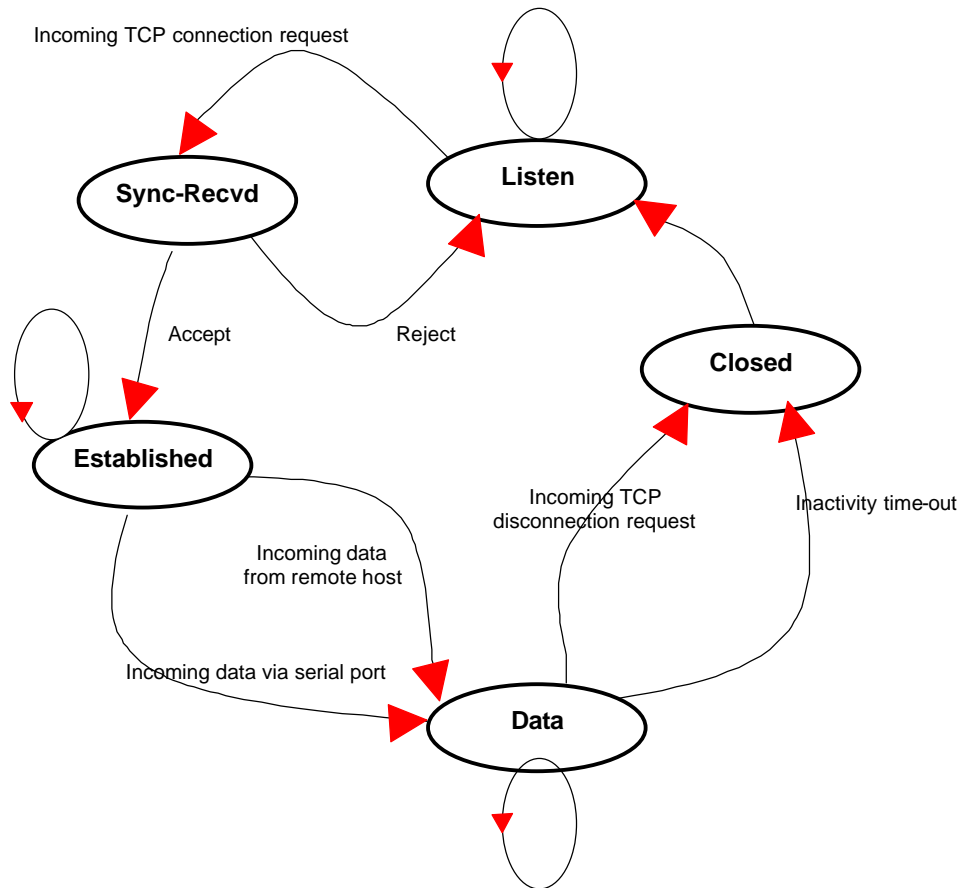

Figure 4-4. State Transition Diagram of TCP server mode

### 3) Parameters

#### Local port

This is the TCP port number through which remote host can connect a TCP session, and, send and receive data. Incoming connection request to the ports other than *Local Port* will be rejected. The HelloDevice Pro Series does not restrict the number to a specific range, but it is strongly recommended not to use the well-known ports for certain application (See Appendix D. *Well-known Port Numbers*). To change the port number, select menu 2 on the *TCP Server* mode configuration screen.



```
-----  
serial configuration -->port#1 --> TCP/IP  
-----  
Select menu  
1. Host mode : TCP Server  
2. Local port : 6000  
  <ESC> Back, <ENTER> Refresh  
-----> 2  
Enter local port number : 6001
```

Figure 4-5. Changing Local TCP Port number

### 4.1.3 TCP client mode operations

The HelloDevice Pro Series works as a TCP client, and the default TCP state is [Closed] in this mode. The remote host will be either Ethernet-Serial communication devices acting as a TCP server or a socket program acting as a TCP server running on users' PC.

#### 1) Typical State Transition

[Closed] --> [Sync-Sent] --> [Established] --> [Data] --> [Closed]

At start-up, an initial TCP state is [Closed]. If there is any incoming data through the serial port, the HelloDevice Pro Series will try to connect to a user-defined remote host. Then, the state will be changed to [Sync-Sent], which means the connection request is being sent. If the remote host accepts the request, the state will be changed into [Established], which means a session has been opened. For a while, data will be transferred between the hosts. This is [Data] state. The session will be disconnected due to the request of one of them, which is its original state, [Closed].

#### 2) Operations

##### Serial data transfer

Whenever the serial device sends data through the serial port of the HelloDevice Pro Series, data will be accumulated to the serial port buffer of the HelloDevice Pro Series. If the internal serial port buffer is full or inter-character time interval reaches to the time specified as *inter-character timeout* value, it tries to connect to the user-defined IP address (or domain name) of the remote host, if TCP session is not established yet (See *Options* in section 4.4 for details on *inter-character timeout*). If the HelloDevice Pro Series succeeds in connecting to the remote host, the data in the serial port buffer will be transferred to the host. Otherwise, all the data stored in the buffer will be cleared.

##### Session disconnection

The connected session will be disconnected when the remote host sends disconnection request

or when no data transfer activity is found through the serial port for certain amount of time, which is “*Inactivity timeout*” (See *Options* in section 4.4 for details on *Inactivity timeout*). All the data remained in the serial port buffer will be cleared when it is disconnected.

#### Connection request from remote host

All the incoming TCP connection requests will be rejected in *TCP client* mode.

#### Cyclic Connection

If *Cyclic Connection* function is enabled, the HelloDevice Pro Series will make an attempt to connect to the user-defined remote host at certain interval even if there’s no incoming serial data from the device. If the remote host prepares certain data, it will be transferred to the serial device via its serial port after the connection is established. Eventually, users can monitor the serial device periodically by making the remote host send the serial command to the HelloDevice Pro Series whenever it is connected to the remote host. This option is useful when users need to gather the device information periodically even if the serial device does not send its data periodically. Figure 4-6 shows the State Transition Diagram of the session operations in *TCP client* mode.

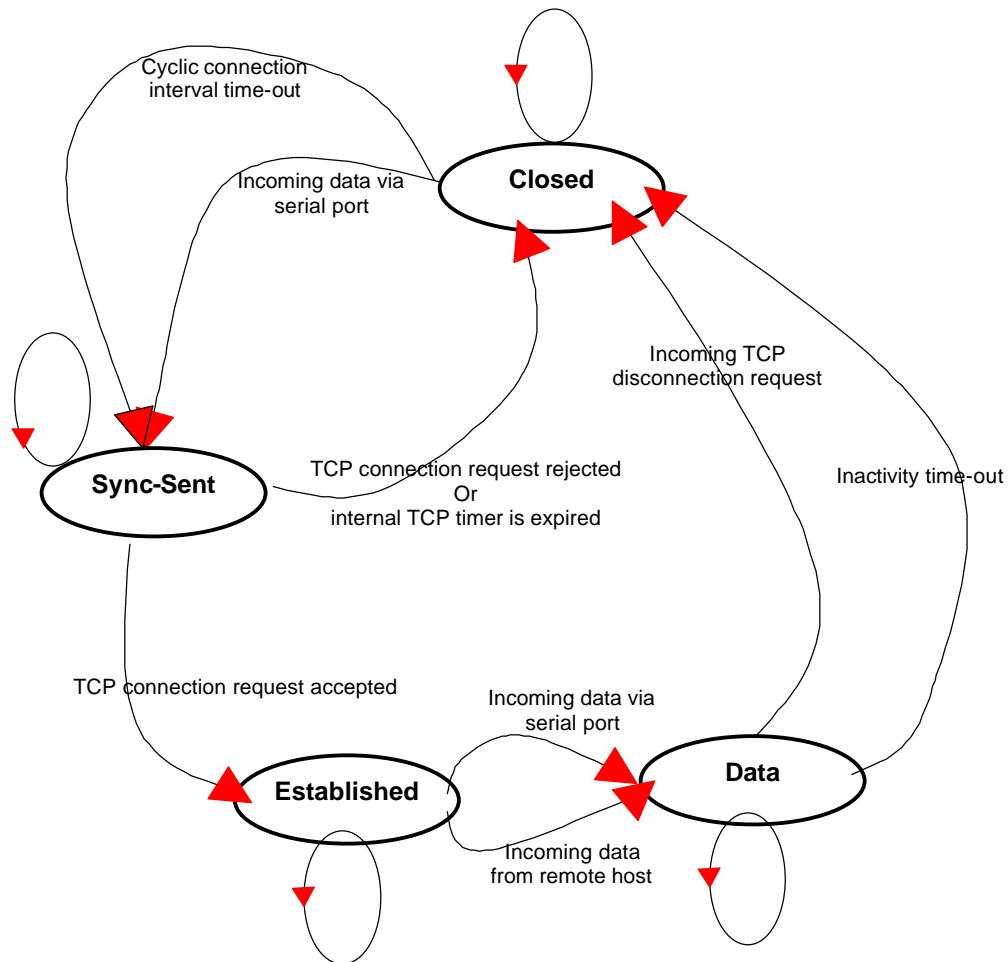

Figure 4-6. State Transition Diagram of TCP client mode

### 3) Parameters

#### Remote IP address (or domain name) and Remote Port

This is the information on the remote host to which the HelloDevice Pro Series will try to connect in *TCP client* mode. The IP address (or domain name) should be specified together with the TCP port number. To specify the information on the remote host, select menu 2 on the *TCP Client* mode configuration screen. The format of remote host information is as follows.

```
[IP address (or domain name)]:[TCP Port number]
```

e.g.)

```
211.116.20.197:1221 : IP address 211.116.20.197, Port 1221
```

```
ser.sena.com:6001 : domain name ser.sena.com, Port 6001
```

```
-----  
serial configuration -->port#1 --> TCP/IP  
-----  
Select menu  
1. Host mode : TCP Client  
2. Destination IP & port : 192.168.1.120:6010  
3. Cyclic connection : Disable  
  <ESC> Back, <ENTER> Refresh  
-----> 2  
Enter destination IP and port (ex: 192.168.1.1:7001)  
-----> 192.168.1.200:6001  
  
-----  
serial configuration -->port#1 --> TCP/IP  
-----  
Select menu  
1. Host mode : TCP Client  
2. Destination IP & port : 192.168.1.200:6001  
3. Cyclic connection : Disable  
  <ESC> Back, <ENTER> Refresh  
----->
```

Figure 4-7. Set up remote host information

#### Cyclic connection interval

This is the time interval at which the HelloDevice Pro Series will try to connect to the remote host regardless of the existence of incoming data from the serial port. If the interval is specified with a valid value other than 0, the function is enabled. The time interval will be the specified value by the unit of minute. To specify the interval, select menu 3 on the *TCP Client* mode configuration screen.

```

-----
serial configuration -->port#1 --> TCP/IP
-----
Select menu
1. Host mode : TCP Client
2. Destination IP & port : 192.168.1.200:6001
3. Cyclic connection : Disable
  <ESC> Back, <ENTER> Refresh
-----> 3
Enter cyclic connection interval in minute(0=disable) : 10

-----
serial configuration -->port#1 --> TCP/IP
-----
Select menu
1. Host mode : TCP Client
2. Destination IP & port : 192.168.1.200:6001
3. Cyclic connection : 10 Min
  <ESC> Back, <ENTER> Refresh
----->

```

Figure 4-8. Set up Cyclic Connection interval

#### 4.1.4 TCP server/client mode operations

The HelloDevice Pro Series works as either TCP server or client according to the situation. This will be the typical mode for most applications, since it will transfer the data either from serial port or from TCP port. The default TCP state is [Listen] which is the same as that of *TCP server* mode.

##### 1) Typical State Transition

[Listen] --> [Sync-Received] --> [Established] --> [Data] --> [Closed] --> [Listen]

Or

[Listen] --> [Sync-Sent] --> [Established] --> [Data] --> [Closed] --> [Listen]

The initial state is [Listen]. If there are data coming from the serial port, it will connect to the remote host as a TCP client. If there is incoming connection request from the remote host, it will accept the connection as a TCP server, and then transfer data through the serial port. Thus, users can assume that the HelloDevice Pro Series is always connected to the specified remote host.

##### 2) Operations

The only difference from *TCP server* mode is that the HelloDevice Pro Series will try to connect and send serial data to the remote host even if the TCP session is not established. The difference from *TCP client* mode is that it will accept incoming connection request from remote host if the session is not established. The detailed operation principles are the same as that of *TCP server* and *TCP client*

mode. See section 4.1.2 and 4.1.3 for more details on each session mode.

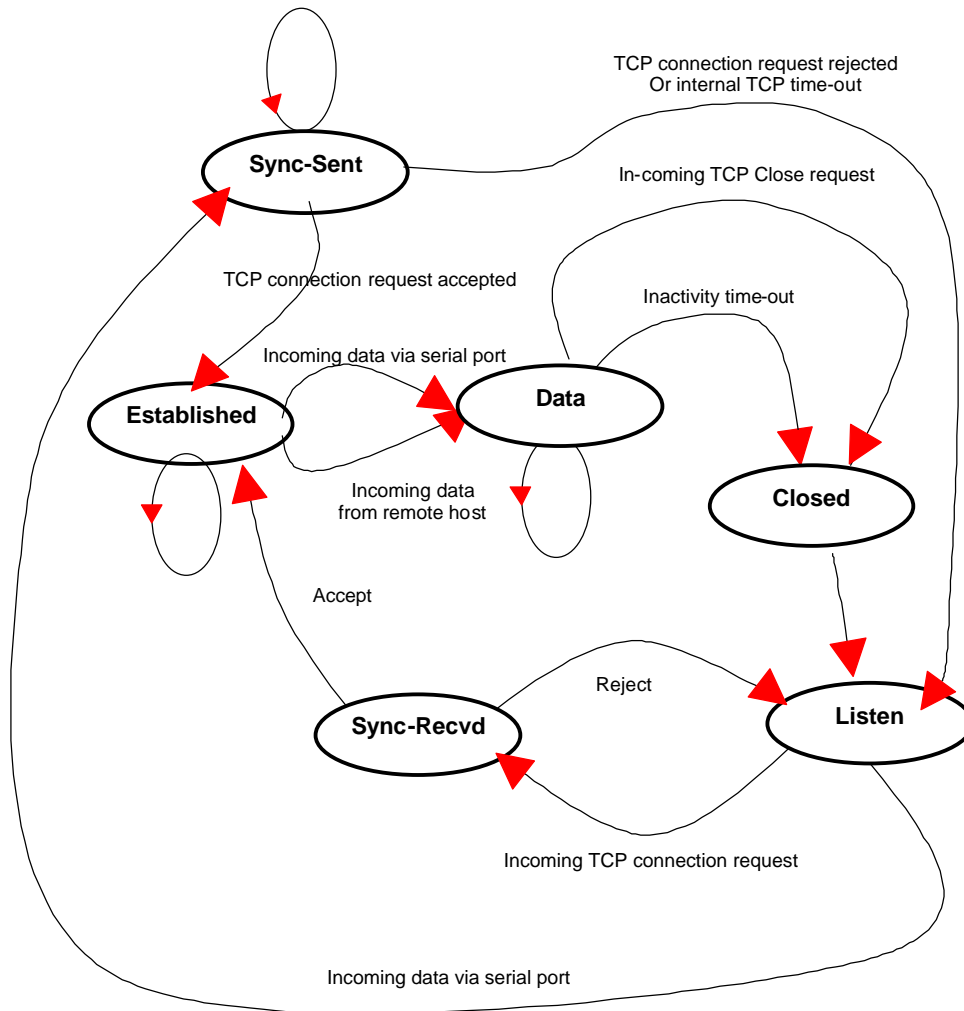

Figure 4-9. State Transition Diagram of TCP server/client mode

### 3) Parameters

#### Local Port

See section 4.1.2 for details

#### Remote IP address (or domain name) and Remote Port

See section 4.1.3 for details

#### Cyclic connection interval

See section 4.1.3 for details

```
-----  
serial configuration -->port#1 --> TCP/IP  
-----  
Select menu  
1. Host mode : TCP Server & client  
2. Local port : 6000  
3. Destination IP & port : 192.168.1.200:6001  
4. Cyclic connection : 10 Min  
  <ESC> Back, <ENTER> Refresh  
----->
```

Figure 4-10. Set up parameters for TCP server/client mode

### 4.1.5 UDP tunneling mode operations

The UDP tunneling mode operation is similar to that of *TCP server/client* mode except that it is based on UDP protocol and only one pre-defined remote host is able to communicate with the HelloDevice Pro Series. Users do not have to configure the parameter of *inactivity timeout*, since UDP is a connectionless protocol.

#### 1) Operations

If a remote host sends a UDP datagram to the UDP *Local port* of the HelloDevice Pro Series, it checks if the IP address of the host is the same as the pre-defined *Destination IP* address. If the IP addresses are the same, the HelloDevice Pro Series transfers the data through the serial port. Otherwise, the HelloDevice Pro Series discards the incoming UDP datagram.

If there is any incoming data from the serial port, the HelloDevice Pro Series transfers the data to the remote host defined as *Destination IP & Port*. Although the remote port is not open, the HelloDevice Pro Series does not transfer the data again.

#### 2) Parameters

##### Local port

The concept is the same as that of TCP communication. See *TCP Server mode operations* in the section 4.1.2 for details.

##### Remote IP address (or domain name) and Remote Port

The concept is the same as that of TCP communication. See *TCP Client mode operations* in the section 4.1.3 for details.

```
-----  
serial configuration -->port#1 --> TCP/IP  
-----  
Select menu  
1. Host mode : UDP tunneling  
2. Local port : 6000
```

```
3. Destination IP & port : 192.168.1.200:6001
<ESC> Back, <ENTER> Refresh
----->
```

Figure 4-11. Set up parameters for UDP tunneling mode

## 4.1.6 UDP server mode operations

While UDP tunneling mode allows only one remote host for UDP communications, UDP server mode allows any remote host to access the HelloDevice Pro Series. In this mode, the HelloDevice Pro Series gets the information on the remote host from the latest incoming datagram information and keeps this information for *inactivity timeout* management, which is configured in *Serial Configuration - Options* menu (see 4.4.1 for detail).

### 1) Operations

In UDP server mode, a remote host should initiate UDP data communication. If there is any incoming UDP datagram to the HelloDevice Pro Series, it will make a virtual connection with the remote host for *inactivity timeout* duration. Before the *inactivity timeout* value expires, the HelloDevice Pro Series transfers the UDP data to the serial port, and send back the data from the serial port to the latest remote host who sent the UDP datagram. Virtual connection timeout will be reset to *inactivity timeout* value whenever there is any data transfer between remote host and the serial device. If other remote hosts send UDP datagrams while a virtual connection is established, the UDP datagram will be discarded. If there is no data transfer during *inactivity timeout*, the virtual connection will be closed and other remote hosts can access the HelloDevice Pro Series from then on.

### 2) Parameters

#### Local port

The concept is the same as that of TCP communication. See *TCP Server mode operations* in the section 4.1.2 for details.

```
-----
serial configuration -->port#1 --> TCP/IP
-----
Select menu
1. Host mode : UDP server
2. Local port : 6000
<ESC> Back, <ENTER> Refresh
----->
```

Figure 4-12. Set up parameters for UDP server mode

### 4.1.7 Modem emulation mode operations

In modem emulation mode, the serial port process acts as if it is a modem attached to the serial device. It accepts AT modem commands and answers to them, as modems would do. It also handles the modem signals correctly. Modem emulation mode is useful in the following cases.

**- There already exists a modem attached to the users' serial device.**

If users' serial device already has a modem for phone-line connection, it can be just replaced by the HelloDevice Pro Series for Ethernet connection. What users need to do is to use an IP address (or domain name) instead of phone number as a parameter of ATA/ATDT commands.

**- It is required to send serial data to the multiple remote hosts.**

If the serial device should send data to the multiple hosts, modem emulation mode is required. For example, the first data from the serial device can be sent to the first data acquisition server and the second to the second server. What user device has to do is to change the IP address (or domain name) parameter whenever the device sends ATD(T) XXX command.

By using the modem emulation mode of the HelloDevice Pro Series, users can have their serial device connected to the Ethernet network easily, which is cheaper than using phone line modem. Table 4-3 is a summarized AT command table which is supported by the HelloDevice Pro Series. Table 4-4 is a summarized AT commands response numeric codes. Figure 4-12 shows the typical case of the serial port command flow when ATDA command is used to connect to the Ethernet network.

Table 4-3. AT commands supported in the Pro Series

Command	Internal Operation	Response <sup>1</sup> (Verbose Code)
+++	Return to command input mode	OK
A/	Repeat last command	
ATD(T)[remote IP]:[remote port]	Set TCP mode as TCP client mode. And then, try to connect to the specified remote host. e.g. atdt192.168.1.9:1002: Connect to IP address, 192.168.1.9, port 1002	If successful, CONNECT [CR][LF] If failure in connection, NO CARRIER [CR][LF] If other errors, ERROR [CR][LF]
AT or ATZ	Initialize TCP socket and serial port	If successful, OK [CR][LF]  If failure, ERROR [CR][LF]
ATA[Local port number]	Set TCP mode as TCP server mode. And then, set TCP state as [Listen].	
ATEn	E, E0: Disable echo E1: Enable echo	

<sup>1</sup> If Echo mode is enabled, the command will be sent back first. And then, corresponding response will be sent. If disabled, only response will be sent.



ATHn	H, H0, H1: Disconnect current TCP connection All the data will be cleared	
ATOn	O, O0: Turn to data mode	
ATQn	Q, Q0: Response display on (default) Q1: Response display off	
ATVn	V, V0: Response = <numeric code> [CR][LF] V1 (default): Response = <verbose code> [CR][LF]	
AT&Dn	D, D0: ignore DTR(PC) signal D2(default): disconnect TCP session	
AT&Fn	F, F0, F1: Restore default modem settings	
AT&Kn	K, K0: No flow control K3: RTS/CTS flow control (default) K4: Xon/Xoff (if supported)	
AT&Sn	S, S0: DSR(PC) always high S1: DSR(PC) shows TCP connection	
ATIn	I, I0 : display "Sena Technologies, Inc." I3 : display model number Others : display "OK"	
AT\Tn	Set inactivity timer to n minutes \T, \T0: inactivity timer disabled (default)	OK [CR][LF]
ATBn, ATCn, ATLn, ATMn, ATNn, ATP, ATT, ATYn, AT%Cn, AT%En, AT&Bn, AT&Gn, AT&In, AT&Qn, AT&V, ATjMn, AT \An, AT\Bn, AT\Wn	None	OK [CR][LF]
ATS?, ATSn=x, AT&Cn, AT&Wn, AT&Zn=x	None	ERROR [CR][LF]
ATFn	None	If n=1 OK [CR][LF] If others, ERROR [CR][LF]
ATWn, ATXn	None	If n=0 OK [CR][LF] If others, ERROR [CR][LF]

Table 4-4. AT commands Response Code

Verbose Code (After "ATV1" command executed)	Numeric Code (After "ATV0" command executed)	Description
OK	0	Command executed
CONNECT	1	Modem connected to line
RING	2	A ring signal has been detected
NO CARRIER	3	Modem lost carrier signal
ERROR	4	Invalid command

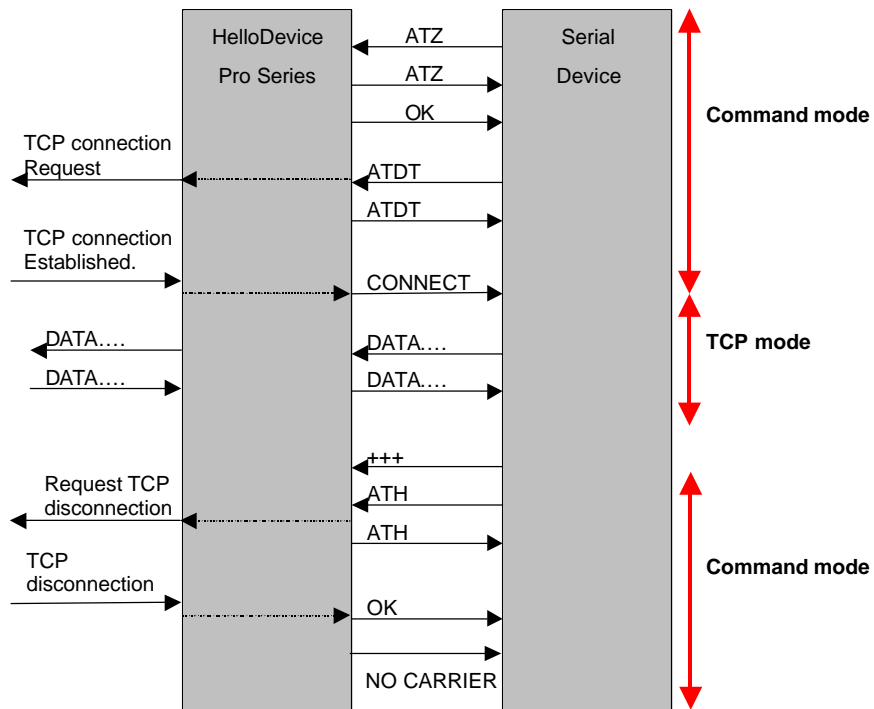

Figure 4-13. Typical case of command/data flow of modem emulation mode

```

-----
serial configuration -->port#1 --> TCP/IP
-----
Select menu
1. Host mode : Modem emulation
  <ESC> Back, <ENTER> Refresh
----->

```

Figure 4-14. Set Modem Emulation mode

## 4.2 UART configuration

To attach the serial device to the HelloDevice Pro Series serial port, its serial port operation should match exactly to that of the serial device. *UART* parameters are required to match this serial communication operation. To change the *UART* parameters, users need to go to *Serial port configuration-*UART* configuration* menu screen.

```
-----  
Serial configuration --> port#1 ---> UART  
-----  
Select menu  
1. Type : RS232  
2. Baud rate : 9600  
3. Data bits : 8  
4. parity : None  
5. Stop Bits : 1  
6. Flow control : Hardware  
7. DTR behavior : Always High  
8. DSR behavior : None  
  <ESC> Back, <ENTER> Refresh  
----->
```

Figure 4-15. UART configuration menu screen

## 4.2.1 Type

First of all, the HelloDevice Pro Series and the serial device must agree on the serial communication type, which is one of RS232, RS422, RS485 echo mode or RS485 non-echo mode. The HelloDevice Pro Series serial ports are configured for RS232 communication as a factory default, but they can also be configured for RS422 and RS485 communication. To change the serial communication type, set up the mode in the *Type* menu. See Appendix B for serial port connections due to the *Type* setup.

The HelloDevice Pro Series supports two types of RS485 communication – echo mode and non-echo mode, which are both two-wire mode. In RS485 echo mode, all data sent to the serial port are received back from the serial port automatically and compared with the data sent for the data integrity while there is no action of receiving-back in non-echo mode.

```
-----  
Serial configuration --> port#1 ---> UART  
-----  
Select menu  
1. Type : RS232  
2. Baud rate : 9600  
3. Data bits : 8  
4. parity : None  
5. Stop Bits : 1  
6. Flow control : Hardware  
7. DTR behavior : Always High  
8. DSR behavior : None  
  <ESC> Back, <ENTER> Refresh  
-----> 1  
Select serial type  
1 = RS232, 2 = RS485 Echo, 3 = RS485 NonEcho, 4 = RS422  
----->
```

Figure 4-16. Set up Serial communication type

## 4.2.2 Baud rate

The valid baud rate for the HelloDevice Pro Series is as follows.

**1200, 2400, 4800, 9600, 14400, 19200, 38400, 57600 and 115200**

The baud rate can be changed by selecting the menu of *Serial port configuration-UART configuration-Baud rate*.

```
-----  
Serial configuration --> port#1 ---> UART  
-----  
Select menu  
1. Type : RS232  
2. Baud rate : 9600  
3. Data bits : 8  
4. parity : None  
5. Stop Bits : 1  
6. Flow control : Hardware  
7. DTR behavior : Always High  
8. DSR behavior : None  
  <ESC> Back, <ENTER> Refresh  
-----> 2  
Select baud rate  
  1 = 1200, 2 = 2400, 3 = 4800, 4 = 9600  
  5 = 19200, 6 = 38400, 7 = 57600, 8 = 115200  
----->
```

Figure 4-17. Set up the baud rate

## 4.2.3 Data bits, Stop bits, Parity

The factory default setting of the *data bits*, *stop bits* and *parity* are 8, 1 and None. They can be changed using the menu 3, 4 and 5.

```
-----  
Serial configuration --> port#1 ---> UART  
-----  
Select menu  
1. Type : RS232  
2. Baud rate : 9600  
3. Data bits : 8  
4. parity : None  
5. Stop Bits : 1  
6. Flow control : Hardware  
7. DTR behavior : Always High  
8. DSR behavior : None  
  <ESC> Back, <ENTER> Refresh  
-----> 3 (or 4 or 5)  
  
  Select data bits (1 = 7 bits, 2 = 8 bits) :  
(Or  
  Select parity (1 = None, 2 = Even, 3 = odd) :  
  Select stop bits (1 = 1 bit , 2 = 2 bits) :  
)
```

Figure 4-18. Set up the data bits, stop bits, parity

## 4.2.4 Flow control

The factory default setting of the flow control is *None*. Only hardware flow control using RTS/CTS is supported by the HelloDevice Pro Series. Hardware flow control method controls data communication flow by sending signals back and forth between two connected devices.

### Note:

Flow control is supported only in RS232 mode. RS422 and RS485 mode do not support any kind of flow control method in hardware or software.

It can be configured using the menu *6.Flow control*.

```
-----  
Serial configuration --> port#1 ---> UART  
-----  
Select menu  
1. Type : RS232  
2. Baud rate : 9600  
3. Data bits : 8  
4. parity : None  
5. Stop Bits : 1  
6. Flow control : Hardware  
7. DTR behavior : Always High  
8. DSR behavior : None  
<ESC> Back, <ENTER> Refresh  
-----> 6  
Select flow control (1 = None, 2 = Hardware) :
```

Figure 4-19. Set up the flow control

## 4.2.5 DTR/DSR behavior

The purpose of the DTR/DSR pin is to emulate modem signal control or to control TCP connection state by using serial port signal. The DTR is a write-only output signal, whereas the DSR is a read-only input signal in the HelloDevice Pro Series side.

The DTR output behavior can be set to one of three types: *always high*, *always low* or *show TCP connection*. If the DTR behavior is set to *show TCP connection*, the state of the DTR pin will be maintained high if the TCP connection is established.

The DSR input behavior can be set to one of three types: *none*, *open/close TCP connection* or *allow TCP connection only by high*. *Open/close TCP connection* is valid only if the host mode is a TCP client or equivalent. If the DSR behavior is set to *open/close TCP connection*, the high state of the DSR pin will make the HelloDevice Pro Series send a connection request to the specified destination host, whereas the low state close a connection. *Allow TCP connection only by HIGH* is valid only if host mode is TCP server or equivalent. If this option is set, the incoming TCP connection request will be accepted only when the DSR signal is high state.

```

-----> 7
Select DTR output behavior
  1 = Always HIGH
  2 = Always LOW
  3 = Show TCP connection (HIGH while connected)
---->

```

*Figure 4-20. Set up the DTR output behavior*

```

-----> 8
Select behavior on DSR input
  1 = None
  2 = Allow TCP connection only by HIGH
    (TCP server or corresponding mode only)
  3 = Open/close TCP connection
    (Open = HIGH, Close = LOW, TCP client or corresponding mode only)
----->

```

*Figure 4-21. Set up the DSR output behavior*

### 4.3 Cryptography configuration

The HelloDevice Pro Series supports encrypted sessions for only TCP modes including modem emulation mode (not UDP mode). By setting the cryptography method as 3DES, the HelloDevice Pro Series can communicate with other HelloDevice Pro Series in encrypted sessions. If you need your PC to communicate with HelloDevice Pro Series using encryption, please contact Sena technical support.

```

-----
Serial configuration --> port#1 ---> Cryptography
-----
Select menu
1. Cryptography method : None
  <ESC> Back, <ENTER> Refresh
-----> 1
Select cryptography method (1 = None, 2 = 3DES) : 2

-----
Serial configuration --> port#1 ---> Cryptography
-----
Select menu
1. Cryptography method : 3DES
2. Key string : Encryption
  <ESC> Back, <ENTER> Refresh
-----> 2
Enter arbitrary key string (maximum 31 chars)
-----> Anykeystring

```

*Figure 4-22. Set up the cryptography method and cryptography key string*

## 4.4 Options

### 4.4.1 Inactivity timeout

The purpose of this parameter is to maintain the TCP connection state as *Closed* or *Listen* in TCP host modes or to close UDP virtual connection in UDP server mode unless there is any data transfer between the serial device and the HelloDevice Pro Series. If there is no incoming or outgoing data through the serial port during the specified *inactivity timeout* interval, the existing TCP connection or virtual UDP connection will be closed automatically.

If the value of *inactivity timeout* is set to 0 and the host mode is set to one of the TCP modes, the current TCP connection is maintained unless there's no connection close request. Although *inactivity timeout* is disabled, the HelloDevice Pro Series will check the connection status between the HelloDevice Pro Series and the remote host by sending "keep alive" packets periodically. If the remote host does not answer the packets, it is regarded that the connection is down unintentionally. Then, the HelloDevice Pro Series will force to close the existing TCP connection.

If the value of *inactivity timeout* is set to 0 and the host mode is set to UDP server mode, virtual UDP connection with the first remote host that sends UDP packet to the HelloDevice Pro Series will be maintained forever till device is rebooted.

#### **Note:**

At least, this value should be set larger than that of *inter-character timeout*. To prevent the unintended loss of data due to the session disconnection, it is highly recommended that this value is set large enough so that the intended data transfer is completed.

### 4.4.2 Inter-character timeout

This parameter defines the interval that the HelloDevice Pro Series fetches the overall serial data from its internal buffer. If there is incoming data through the serial port, the HelloDevice Pro Series stores data into the internal buffer. The HelloDevice Pro Series transfers data stored in the buffer via TCP/IP, only if the internal buffer is full or if the inter-character time interval reaches to the time specified as *inter-character timeout*.

Optimal inter-character timeout would be different according to your application but at least it must be larger than one character interval within specified baud rate. For example, assume that the serial port is set to 1200 bps, 8 Data bits, 1 stop bit, and no parity. In this case, the total number of bits to send a character is 10 bits and the time required to transfer one character is

$$10 \text{ (bits)} / 1200 \text{ (bits/s)} * 1000 \text{ (ms/s)} = 8.3 \text{ ms.}$$

Therefore, you have to set *inter-character timeout* to be larger than 8.3 ms. The *inter-character timeout* is specified in milliseconds and must be larger than 10 ms.

If users want to send the series of characters into a packet, serial device attached to the HelloDevice Pro Series should send characters without time delay larger than *inter-character timeout* between characters and the total length of data must be smaller than or equal to the HelloDevice Pro Series internal buffer size. The buffer size of HelloDevice Pro Series is 600 bytes per a port.

```
-----  
Serial configuration --> port#1 ---> option  
-----  
Select menu  
1. Inactivity timeout : 100 sec  
2. Inter-character timeout : 1 ms  
  <ESC> Back, <ENTER> Refresh  
-----> 1  
Enter inactivity timeout value to disconnect TCP connection in seconds  
( 1 - 3600)Sec , 0 = unlimited  
-----> 300  
  
-----  
Serial configuration --> port#1 ---> option  
-----  
Select menu  
1. Inactivity timeout : 300 sec  
2. Inter-character timeout : 1 ms  
  <ESC> Back, <ENTER> Refresh  
-----> 2  
Enter Inter-character timeout in milliseconds (1 - 10000) : 100
```

*Figure 4-23. Set up the options of inactivity timeout and Inter-character timeout*



## 5: Advanced Options Configurations

With advanced options, you can configure remote host access control, locating server configuration and manual DNS server settings. Table 5-1 shows the hierarchical view of advanced options.

```

-----
Advanced options
-----
Select menu
1. Remote host access control
2. Manual DNS configuration for DHCP & PPPoE
3. Locating server configuration
<ESC> Back, <ENTER> Refresh
----->

```

Figure 5-1. Main menu screen of the Advanced Options

Table 5-1. Hierarchical view of the advanced options menu items

<b>Remote Host access control</b>	Telnet configuration enable/disable	
	Allowed remote hosts for configuration	
	Allowed remote hosts for port#n	
<b>Manual DNS for DHCP &amp; PPPoE</b>	Enable/Disable	
	Primary DNS	
	Secondary DNS	
<b>Locating server Configuration</b>	Enable	Mode
		Server IP/Port
	Disable	Mode

### 5.1 Remote host access control

The HelloDevice Pro Series has an IP address based filtering method to control the access to the telnet or the serial port of the HelloDevice Pro Series from the remote hosts to prevent unauthorized access. You can allow one of the following cases by setting the parameter.

- Only one host of specific IP address can access the HelloDevice Pro Series
- Hosts on the specific subnet can access the HelloDevice Pro Series
- Any host can access the HelloDevice Pro Series

### 5.1.1 Configuration access

The HelloDevice Pro Series remote console access feature can be enabled or disabled by selecting submenu *1.Remote configuration by Telnet*. Factory default setting of this feature is “Enabled”. If the remote configuration feature is enabled, you can specify a host or hosts allowed to access the HelloDevice Pro Series for configuration by selecting submenu *2.Allowed remote hosts for configuration*. When you select this menu, you have to enter the IP address or subnet to be allowed to access the HelloDevice Pro Series in the format of “subnet or IP address/subnet mask”. If you want to allow only a specific host to access the HelloDevice Pro Series for configuration, enter “IP address/255.255.255.255” such as 192.168.1.100/255.255.255.255. If you want to allow any hosts on the specified subnet, enter “subnet/subnet mask” such as “192.168.1.0/255.255.255.0”. If you want to allow any host, enter “0.0.0.0/0.0.0.0”. Please refer to Table 5-2 for more details. Default setting of allowable remote hosts for configuration is “Any”.

Table 5-2 Input examples of allowed remote hosts

Allowable Hosts	Input format
Any host	0.0.0.0/0.0.0.0
192.168.1.120	192.168.1.120/255.255.255.255
192.168.1.1 ~ 192.168.1.254	192.168.1.0/255.255.255.0
192.168.0.1 ~ 192.168.255.254	192.168.0.0/255.255.0.0
192.168.1.1 ~ 192.168.1.126	192.168.1.0/255.255.255.128
192.168.1.129 ~ 192.168.1.254	192.168.1.128/255.255.255.128

```
-----  
Advanced options -> Remote host access control  
-----  
Select menu  
1. Remote configuration by telnet : Enable  
2. Allowed remote hosts for configuration : Any  
3. Allowed remote hosts for Port#1 : Any  
4. Allowed remote hosts for Port#2 : Any  
5. Allowed remote hosts for Port#3 : Any  
6. Allowed remote hosts for Port#4 : Any  
  <ESC> Back, <ENTER> Refresh  
----->
```

Figure 5-2. Set up the parameters for telnet remote configuration access

### 5.1.2 Serial Port access

Similar to remote configuration access control, the remote host for each serial port could be also filtered based on IP address. You can use this option by selecting submenu 3~6. Refer to table 5-2 for more details for the input format.

```

-----> 2 (or 3, 4, 5, 6)
Enter IP address or network of hosts allowed to access
Format) IP-address/subnet-mask
Ex1) 192.168.1.0/255.255.255.0 to allow hosts of 192.168.1.*
Ex2) 192.168.1.99/255.255.255.255 to allow hosts of 192.168.1.99
Ex3) 0.0.0.0 / 0.0.0.0 to allow any remote host
-----> 192.168.0.0/255.255.0.0

```

Figure 5-3. Set up the serial port access option

## 5.2 Manual DNS configuration

If DHCP servers or PPPoE servers do not provide DNS server configuration or if users want to use different DNS servers from automatically provided ones, users can configure DNS servers manually. Factory default setting of manual DNS server configuration is “Disabled”

```

-----
Advanced options -> Manual DNS configuration
-----
Select menu
1. Manual DNS configuration for DHCP & PPPoE : Disable
<ESC> Back, <ENTER> Refresh
-----> 1
Do you want to configure DNS manually for DHCP & PPPoE? (y/n) : y

-----
Advanced options -> Manual DNS configuration
-----
Select menu
1. Manual DNS configuration for DHCP & PPPoE : Enable
2. Primary DNS : 211.172.129.198
3. Secondary DNS : 211.172.129.199
<ESC> Back, <ENTER> Refresh
-----> 2
Enter Primary DNS IP address : 211.116.26.193

```

Figure 5-4. Manual DNS configuration

## 5.3 Locating server

### 5.3.1 Overview

If users want the HelloDevice Pro Series to work as a server (TCP or UDP), the host acting as a client has to know the IP address of the HelloDevice Pro Series. However, under the dynamic IP address environment such as DHCP or PPPoE, arbitrary IP address is assigned to the PS200, which means special consideration is required to access the current IP address of it. To tackle this problem, the

HelloDevice Pro Series can be configured to send its IP address information whenever it is assigned a new IP address or periodically to a specific server called locating server. You can operate a specific host as your locating server or you can use your client host as a locating server simultaneously.

No special library or toolkit to implement locating server is provided. You have to implement your program by yourself using the protocol provided below or contact us.

### 5.3.2 Locating server configuration

Locating server configuration screen is shown in Figure 5-5. You have to configure locating server IP address, locating server UDP port number and connection time interval as well as to use locating server feature or not. Initially locating server feature is configured as “Disabled”.

```
-----  
Advanced options -> Locating server  
-----  
Select menu  
1. Use locating server : Disable  
<ESC> Back, <ENTER> Refresh  
-----> 1  
Do you want to put your information to locating server ? (y/n): y  
  
-----  
Advanced options -> Locating server  
-----  
Select menu  
1. Use locating server : Enable  
2. Locating server connection time interval: 1 Min  
3. Locating server IP address and port : 192.168.1.211 : 9999  
<ESC> Back, <ENTER> Refresh  
-----> 2  
Enter locating server connection time interval in minutes (1 ~ 3600)  
-----> 10  
  
-----  
Advanced options -> Locating server  
-----  
Select menu  
1. Use locating server : Enable  
2. Locating server connection time interval: 10 Min  
3. Locating server IP address and port : 192.168.1.211 : 9999  
<ESC> Back, <ENTER> Refresh  
-----> 3  
Enter locating server IP address and port (EX: 211.116.26.213:9999)  
-----> 211.116.26.213:9999  
  
-----  
Advanced options -> Locating server  
-----  
Select menu  
1. Use locating server : Enable  
2. Locating server connection time interval: 10 Min  
3. Locating server IP address and port : 211.116.26.213 : 9999  
<ESC> Back, <ENTER> Refresh  
----->
```

Figure 5-5. Locating server configuration

### 5.3.3 Locating server communication protocol

When the HelloDevice Pro Series sends its IP address information to the locating server, data format will be as follows:

Description	Magic Cookie	Data(0)	Data(1)	...	Data(n)
Bytes	4	Variable	Variable		Variable
Value	F1-AA-AA-BC				

Data(n) format

Description	Data ID	Length	Data
Bytes	1	1	Variable
Value	1~6	Variable	Variable

Data ID

ID	Description	Length
1	Device name	var
2	Model name	var
3	Serial number	var
4	MAC address	6
5	IP address	4
6	Local ports*	2 or 4 or 8

#### Note:

Local ports: Each 2 byte data represent current local port setting of the corresponding serial port. Local ports data length of PS100 should be 2 bytes, while 4 bytes and 8 bytes for PS200 and PS400 respectively. Configured local TCP (or UDP) port numbers for each serial port are filled with network-order bytes, (i.e. higher bytes first). If the host mode of a serial port is set to client mode, the local port number is regarded as 0.

Example of the PS100:

If port number = 6001 (1771h), Local ports data = 17h, 71h

If host mode is TCP client, Local port data = 0h, 0h

Example of the PS400:

Port1 = 6001 (1771h), Port2 = 6002 (1772h), Port3 = TCP client, Port4 = 6003(1773h)

Local ports data = 17h, 71h, 17h, 72h, 00h, 00h, 17h, 73h

## 6: System Status and Log

The HelloDevice Pro Series provides system status display and log data display for management. System status includes Ethernet status and status of each serial port. In addition, the HelloDevice Pro Series can be configured to deliver log data automatically by email to a specific recipient. Users can use or configure these features by selecting menu *3.System status & log* in the main menu screen.

```
-----  
System status  
-----  
Select menu  
1. Display system status  
2. Display log  
3. Reset incoming/outgoing statistics  
4. Clear log  
5. Send log by Email : Disable  
  <ESC> Back, <ENTER> Refresh  
----->
```

Figure 6-1 System status menu

### 6.1 Display system status

Users can view current system status by selecting submenu *1.Display system status*. System status includes Ethernet status, serial port status and incoming/outgoing data statistics. Users can reset Incoming/outgoing statistics by selecting submenu *3.Reset incoming/outgoing statistics*.

```
-----  
System status  
-----  
Select menu  
1. Display system status  
2. Display log  
3. Reset incoming/outgoing statistics  
4. Clear log  
5. Send log by Email : Disable  
  <ESC> Back, <ENTER> Refresh  
-----> 1  
  
-----  
System information  
-----  
Model No.: PS200                               Serial No.: PS200-02020001
```

```

F/W REV.   : V1.00                MAC Address : 00-01-95-04-04-33
Cur Status : Running             Current time : 2038/05/10 04:34:10
-----
IP information
-----
IP Mode : Static                  IP Expiration : N/A
IP Address : 192.168.2.100        Subnetmask : 255.255.0.0
Gateway : 192.168.1.1            Receive/Transmit errors : N/A
Primary DNS : 211.172.129.198    Secondary DNS : 211.172.129.199
-----
Port #0 information
-----
Connection Mode : Modem Emul      Local port : 6000
Destination : 192.168.1.120:6010  Host allowed : 0.0.0.0/0.0.0.0
Incoming bytes : 268492           Outgoing bytes : 285121
UART : 9600-N-8-1-Hardware       Encryption : 3DES
Inactivity timeout : 300 sec      Inter-character timeout : 100 ms
...
-----
Port #3 information
-----
Connection Mode : TCP Server      Local port : 6003
Destination : 192.168.1.120:6013  Host allowed : 0.0.0.0/0.0.0.0
Incoming bytes : 0                Outgoing bytes : 0
UART : 9600-N-8-1-Hardware       Encryption : None
Inactivity timeout : 100 sec      Inter-character timeout : 1 ms
End of Status
Press Enter

```

Figure 6-2. System status display (PS400)

## 6.2 Display log data

Users can see the system log by selecting submenu *2.Display log*. Users can also clear current log data by selecting submenu *4.Clear log*.

```

2002-02-10 04:41:32 > ### No valid log table. Initialize logs ###
2002-02-10 04:41:44 > ### Boot up System Start ###
2002-02-10 04:41:44 > ### Start with Static IP by 192.168.2.100 ###
End of Log
Press Enter

```

Figure 6-3. System log display

## 6.3 Automatic log delivery by email

The HelloDevice Pro Series can be configured to send log data automatically if the number of log messages unsend reaches the pre-defined number. Users can enable this feature by selecting submenu *5.Send log by email*. If this feature is enabled, you have to configure email related

information such as number of logs to be sent, SMTP server, log recipient's mail address and device mail address.

The device mail address specifies sender's mail address for the log delivery email. Almost every SMTP servers check sender's mail address with host domain name's validity only. Consequently, for the device mail address, you can use arbitrary username with registered hostname such as *arbitrary\_user@yahoo.com* or *anybody@sena.com*.

```
-----> 5
Select email log send option ( 1 = Enable, 2 = Disable) : 1

-----
System status
-----
Select menu
1. Display system status
2. Display log
3. Reset incoming/outgoing statistics
4. Clear log
5. Send log by Email : Enable
6. Number of log message to send a mail(1 - 100) : 5
7. SMTP server : smtp.yourcompany.com
8. PS-400 mail address : PS200@yourcompany.com
9. Log recipient's mail address : admin@yourcompany.com
<ESC> Back, <ENTER> Refresh
----->
```

*Figure 6-4 Email log send configuration*



## 7: System administration

Users can configure system administration parameters by selecting menu 4. *System administration* in the main menu screen. In this menu, users can configure administrator username, password, current date and time information.

### 7.1 User name and password

Users can change the administrator's username and password as they want. The maximum character length for the both is 31. The default settings of username and password are both "admin".

```
-----  
User Administrator  
-----  
Select menu  
1. Administrator username : admin  
2. Administrator password : *****  
3. Device name : PS200 Device  
4. Date : 2002/02/10  
5. Time : 04:45:38  
  <ESC> Back, <ENTER> Refresh  
-----> 1  
Enter current password : *****  
Enter New Username : root  
>>> Administrator username changed successfully!  
  
-----  
User Administrator  
-----  
Select menu  
1. Administrator username : root  
2. Administrator password : *****  
3. Device name : PS200 Device  
4. Date : 2002/02/10  
5. Time : 04:45:52  
  <ESC> Back, <ENTER> Refresh  
-----> 2  
Enter current password : *****  
Enter New password : ****  
Retype password : ****  
>>> Password changed successfully!  
  
-----  
User Administrator  
-----  
Select menu  
1. Administrator username : root  
2. Administrator password : ****  
3. Device name : PS200 Device  
4. Date : 2002/02/10  
5. Time : 04:45:58  
  <ESC> Back, <ENTER> Refresh  
----->
```

Figure 7-1. Administrator username and password configuration

## 7.2 Date and time settings

The HelloDevice Pro Series has current date and time information, which is backed up by internal battery power. Users can change current date and time by selecting submenu 3 or 4.

```
-----  
User Administrator  
-----  
Select menu  
1. Administrator username : root  
2. Administrator password : ****  
3. Device name : PS200 Device  
4. Date : 2038/05/10  
5. Time : 04:48:03  
  <ESC> Back, <ENTER> Refresh  
-----> 4  
Enter Current Date(yyyy/mm/dd) : 2002/3/14  
  
-----  
User Administrator  
-----  
Select menu  
1. Administrator username : root  
2. Administrator password : ****  
3. Device name : PS200 Device  
4. Date : 2002/03/14  
5. Time : 04:48:15  
  <ESC> Back, <ENTER> Refresh  
-----> 5  
Enter Current Time(hh:mm:ss) : 18:00:00
```

*Figure 7-2. Date and time configuration*

## 8: System tools

The HelloDevice Pro Series provides administrative functions by console such as factory default settings restore, firmware upgrade and ping test. These functions can be found in 6. *System tools* in the main menu.

```
-----  
System tools  
-----  
Select menu  
1. Reload factory default settings  
2. Reload factory default settings except IP setting  
3. Firmware upgrade  
4. Ping Test  
5. Socket reset  
  <ESC> Back, <ENTER> Refresh  
----->
```

Figure 8-1 System tools menu

### 8.1 Factory default reset

Users can restore factory default settings by selecting submenu *1.Reload factory default settings* or by pushing hardware factory default reset switch of the HelloDevice Pro Series. If users want to keep IP configuration after reload of factory settings, select submenu *2.Reload factory default settings except IP settings*.

### 8.2 Firmware upgrade

Firmware of the HelloDevice Pro Series can be upgraded both by serial console or remote console. The latest firmware can be obtained from our web site: <http://www.sena.com/support/downloads/>. For firmware upgrade, your terminal emulation program must support Zmodem transfer protocol. After firmware upgrade, previous settings will be reset to factory default settings except IP configuration settings.

Please follow the instructions below for firmware upgrade:

- 1) Obtain the latest firmware.
- 2) Connect your terminal emulation program using serial console or telnet. If you use serial console of the HelloDevice Pro Series, please remember the setting of the terminal emulation program as follows.

**9600 Baud rate, Data bits 8, Parity None, Stop bits 1, Hardware flow control (RTS/CTS)**

- 3) Select firmware upgrade menu.
- 4) Follow the step as guided by online messages.

```

-----> 3
Are you sure to start firmware upgrade ? (y/n) : y
Preparing for firmware upgrade. Wait a moment...
Transfer firmware by zmodem using your terminal application.
**B01ff000005b157

```

Figure 8-2. Firmware upgrade display

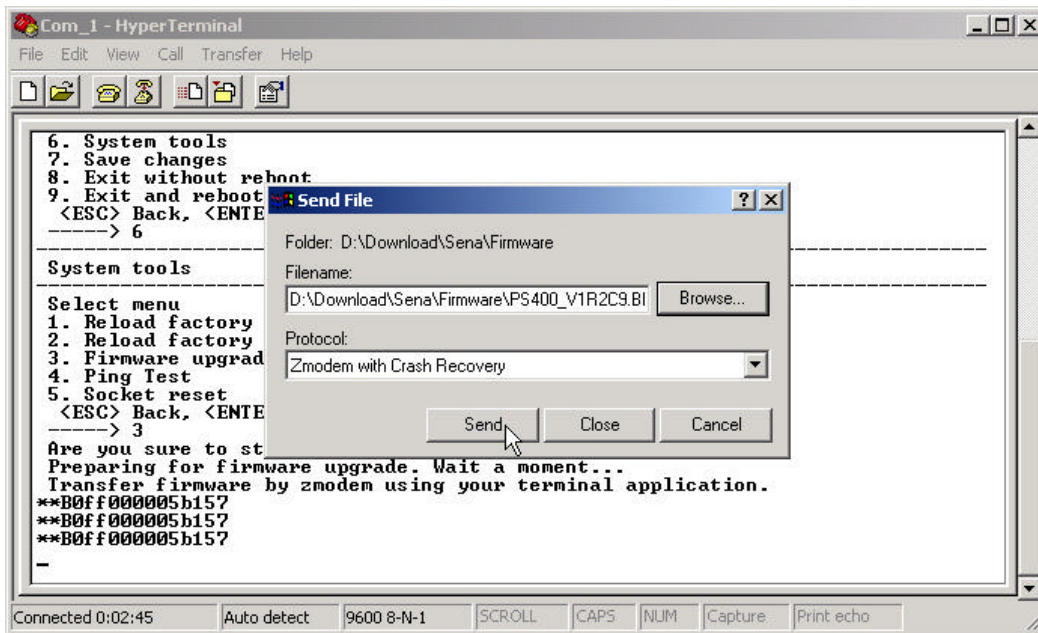

Figure 8-3 Transfer binary file by Zmodem (HyperTerminal)

- 5) If firmware is upgraded successfully, the HelloDevice Pro Series will reboot automatically.
- 6) If the firmware upgrade fails, the HelloDevice Pro Series will display messages as follows, and it will preserve the firmware of current version.

```

-----> 3
Are you sure to start firmware upgrade ? (y/n) : y
Preparing for firmware upgrade. Wait a moment...
Transfer firmware by zmodem using your terminal application.
**B01ff000005b157
**B01ff000005b157
**B01ff000005b157
**B01ff000005b157
**B01ff000005b157
Firmware upgrade failure. Recovering the previous firmware...
Recovering completed. Device will reboot in a moment...

```

Figure 8-4. Firmware upgrade failure message

## 8.3 Ping test

You can test your network configuration by sending ICMP echo messages (ping) to remote hosts in 4. *Ping Test* menu. Figure 8-5 shows how to use ping test function to check network connection.

```
-----> 4
Enter IP Address or Hostname to ping : 192.168.1.1
to 192.168.1.1 pining 4times..
Receive time = 1 ms Sequence num = 0
Receive time = 1 ms Sequence num = 1
Receive time = 1 ms Sequence num = 2
Receive time = 1 ms Sequence num = 3
```

*Figure 8-5 Ping test screen*

## 8.4 Socket reset

You can reset the network socket for the corresponding serial port in 5. *Socket Reset* menu. Figure 8-6 shows how to reset sockets and serial ports manually.

```
-----> 5
Select a serial port to reset:
1 = port#1 : Listen (6000)
2 = port#2 : Listen (6001)
3 = port#3 : Listen (6002)
4 = port#4 : Listen (6003)
-----> 1
Are you sure to reset? (y/n): y
Socket Initialized !
```

*Figure 8-6 Socket reset screen*

## Appendix A: Connections

### A.1 Ethernet Pin outs

The HelloDevice Pro Series uses standard Ethernet connector, which is a shielded connector compliant with AT&T258 specifications. Table A-1 shows the pin assignment and the wire color.

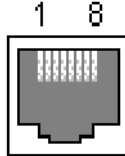

Figure A-1 Pin layout of the RJ45 connector

Table A-1. Pin assignment of the RJ45 connector

Pin	Description	Color
1	Tx+	White with orange
2	Tx-	Orange
3	Rx+	White with green
4	NC	Blue
5	NC	White with blue
6	Rx-	Green
7	NC	White with brown
8	NC	Brown

### A.2 Serial Ports Pin Outs

The pin assignment of the HelloDevice Pro Series DB9 connector is summarized in Table A-2. Each pin has a function according to the serial communication type configuration.

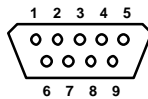

Figure A-2 Pin layout of the DB-9 connector

Table A-2. Pin assignment of the DB-9 connector

Pin	RS232	RS422	RS485
1	-	Tx-	Data-
2	Rx	-	-
3	Tx	Rx-	-
4	DTR	Rx+	-
5	GND	-	-
6	DSR	-	-
7	RTS	-	-
8	CTS	-	-
9	-	Tx+	Data+

### A.3 Ethernet Wiring Diagram

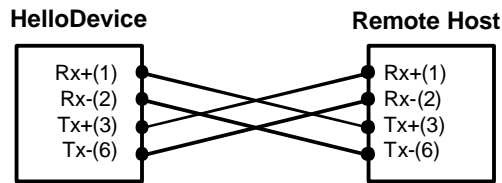

Figure A-3 Ethernet direct connection using crossover ethernet cable

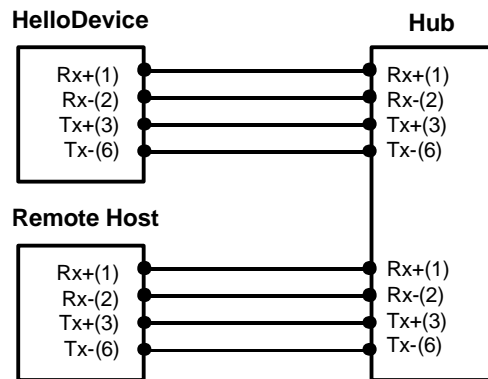

Figure A-4 Ethernet connection using straight through Ethernet cable

### A.4 Serial Wiring Diagram

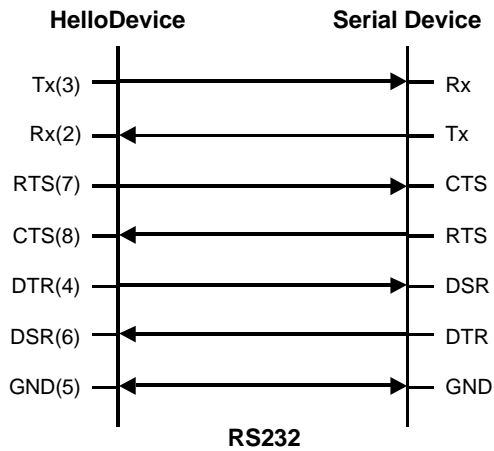

Figure A-5 RS232 wiring diagram

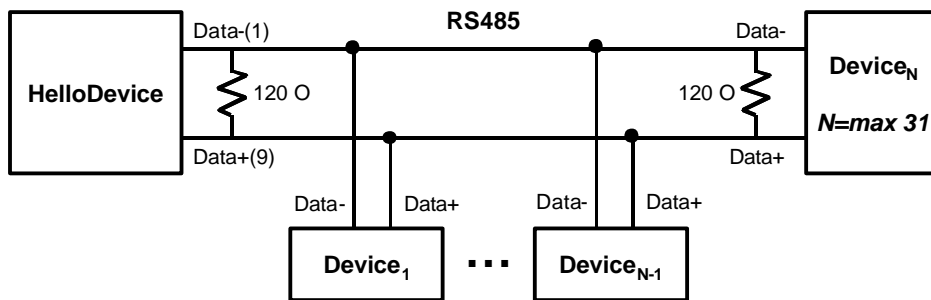

Figure A-6 RS485 wiring diagram

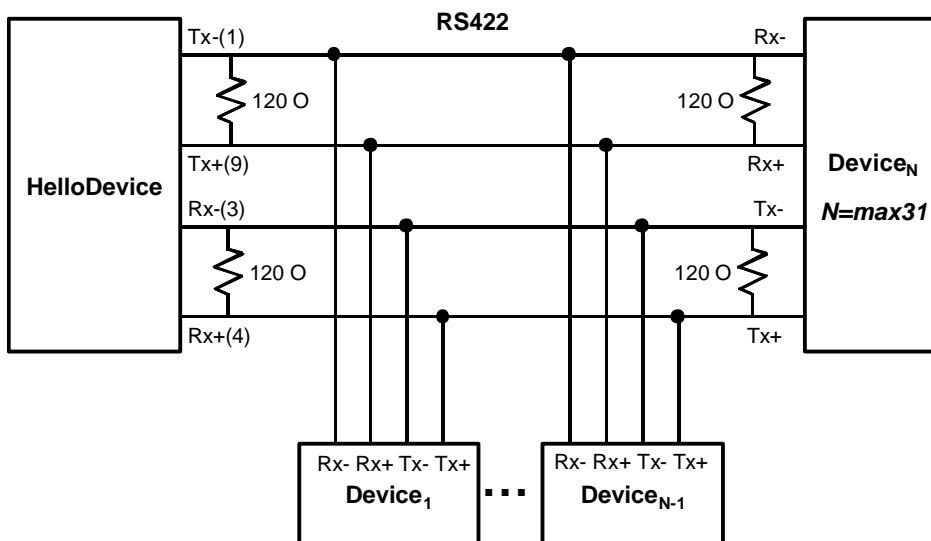

Figure A-7 RS422 wiring diagram



## Appendix B: Well-known port numbers

The port numbers are divided into three ranges: the Well Known Ports, the Registered Ports, and the Dynamic and/or Private Ports. The Well Known Ports are those from 0 through 1023. The Registered Ports are those from 1024 through 49151. The Dynamic and/or Private Ports are those from 49152 through 65535.

The Well Known Ports are assigned by the IANA, and on most systems, can only be used by system processes or by programs executed by privileged users. Table B-1 shows famous port numbers among the well-known port numbers. For more details, please visit IANA website:

<http://www.iana.org/assignments/port-numbers>

*Table B-1 Well-known port numbers*

Port number	Protocol	TCP/UDP
21	FTP (File Transfer Protocol)	TCP
22	SSH (Secure SHell)	TCP
23	Telnet	TCP
25	SMTP (Simple Mail Transfer Protocol)	TCP
37	Time	TCP, UDP
39	RLP (Resource Location Protocol)	UDP
49	TACACS, TACACS+	UDP
53	DNS	UDP
67	BOOTP server	UDP
68	BOOTP client	UDP
69	TFTP	UDP
70	Gopher	TCP
79	Finger	TCP
80	HTTP	TCP
110	POP3	TCP
119	NNTP (Network News Transfer Protocol)	TCP
161/162	SNMP	UDP

## Appendix C: Troubleshooting

### C.1 Power/LED status troubleshooting

Problem	Cause	Action
Power LED does not light up	Power cable is not connected	Check power connection
Link LED does not light up	Ethernet cable is not connected	Check Ethernet cable connection
	Invalid Ethernet cable is used	There are two types of Ethernet cables: Straight-through cable and crossover cable. If you are using an Ethernet hub, use straight-through cable. If direct connection between the HelloDevice Pro Series and remote host is used, use crossover cable instead.
ACT LED does not blink	Invalid IP configuration	Check IP configuration parameters

### C.2 Serial console troubleshooting

Problem	Cause	Action
Serial console is not connected	Invalid serial cable	Be sure to use a serial console cable (null-modem cable) for serial console
	Invalid serial port configuration of terminal emulation program	Check serial port configuration of terminal emulation program: 9600 bps, 8 Data bits, No parity, 1 stop bit, Hardware flow control
Serial console is halted for few seconds periodically	IP mode is DHCP or PPPoE, but IP is not assigned	If IP mode is set to DHCP or PPPoE but IP is not actually assigned because of DHCP server or PPPoE server failure, serial console is halted for few seconds at every 20 seconds. Change IP mode to the static IP mode
Cannot login to console	Invalid username and/or password	Use valid username and password. If username and/or password are lost, perform factory default reset using factory reset switch. Factory default value of username and password are both <i>admin</i>

### C.3 Remote console troubleshooting

Problem	Cause	Action
Cannot connect to the HelloDevice Pro Series using telnet	The HelloDevice Pro Series is not assigned valid IP address	Use serial console to assign valid IP address to the HelloDevice Pro Series
	The HelloDevice Pro Series is configured to reject IP address of the PC	Change the remote host access control parameter using serial console to allow the IP address of the PC

	Someone is using serial console	Exit serial console and retry telnet connection
Cannot login to console	Invalid username and/or password	Use valid username and password. If username and/or password are lost, perform factory default reset using factory reset switch. Factory default value of username and password are both <i>admin</i>

## C.4 IP address troubleshooting

Problem	Cause	Action
Cannot find IP address of the HelloDevice Pro Series		Use serial console to find IP address
		Use HelloDeviceManager program to probe the HelloDevice Pro Series on the network
HelloDeviceManager cannot probe the HelloDevice Pro Series	The HelloDevice Pro Series is not assigned valid IP address	Use serial console to assign valid IP address to the HelloDevice Pro Series
	HelloDeviceManager and the HelloDevice Pro Series are not on the same subnet	Run HelloDeviceManager on the PC that is on the same subnet with the HelloDevice Pro Series

## C.5 DHCP troubleshooting

Problem	Cause	Action
Cannot lease IP address	DHCP server is not working	Check if DHCP server is working correctly
IP address of the HelloDevice Pro Series is changed	DHCP server does not extend lease time	Check if DHCP server is working correctly

## C.6 TCP server operation troubleshooting

Problem	Cause	Action
Cannot connect to the HelloDevice Pro Series	IP configuration of remote host is invalid	Check if IP configuration of the remote host is valid
	Host mode of the HelloDevice Pro Series serial port is not TCP server	Change the host mode of the HelloDevice Pro Series serial port to TCP server or TCP server/client
	IP address of the HelloDevice Pro Series or TCP/UDP port number is wrong	Specify valid IP address and TCP/UDP port number of the HelloDevice Pro Series
	DSR option is set but DSR input is not high	Disable DSR option or make DSR input of the HelloDevice Pro Series high

	The HelloDevice Pro Series is configured to reject IP address of the PC	Change the remote host access control parameter using serial or remote console to allow the IP address of the PC
	TCP connection with the other host is established already	Close established TCP connection or connect later

## C.7 Serial communication troubleshooting

Problem	Cause	Action
Serial data are not transferred by TCP/IP immediately	Too large inter-character timeout	Set inter-character timeout with smaller value
Cannot communicate with the HelloDevice Pro Series	Invalid serial port configuration	Check if serial port configuration of the HelloDevice Pro Series are the same with that of the serial device
Only serial port#2 of PS400 is not working (PS400 only)	Serial console is used	Serial port#2 of the PS400 is used commonly for both data port and serial console port. While serial console is used, data transfer through serial port#2 is disabled. Close serial console to use serial port#2 for data transfer.
Invalid data transferred	Invalid serial port configuration	Check if serial port configuration is correct.
RS485 mode is not working	Invalid serial port configuration	Check if serial port is set to RS485 Echo or RS485 Non-echo mode.
	Terminator resistor is not attached	The HelloDevice Pro Series has no terminator resistor inside for RS485 communication. Please attach a 120 Ω resistor between Data+ and Data- pins.
RS422 mode is not working	Invalid serial port configuration	Check if serial port is set to RS422 mode.
	Terminator resistor is not attached	The HelloDevice Pro Series has no terminator resistor inside for RS422 communication. Please attach 120 Ω resistors between Tx+, Tx- and between Rx+, Rx- pins.