

# **ZigBee OEM Module**

## **ProBee-ZE20S**

### **User Guide**

**Sena Technologies, Inc.**

**Rev 1.10**

**ProBee-ZE20S User Guide**

Firmware version PTV1.X

**Copyright**

Copyright 2011 ~ 2012, Sena Technologies, Inc. All rights reserved.

Sena Technologies reserves the right to make changes and improvements to its product without providing notice.

**Trademark**

ProBee™ is a trademark of Sena Technologies, Inc.

Windows® is a registered trademark of Microsoft Corporation.

Ethernet® is a registered trademark of XEROX Corporation.

**Notice to Users**

When a system failure may cause serious consequences, protecting life and property against such consequences with a backup system or safety device is essential. The user agrees that protection against consequences resulting from system failure is the user's responsibility.

This device is not approved for life-support or medical systems.

Changes or modifications to this device not explicitly approved by Sena Technologies will void the user's authority to operate this device.

**Technical Support**

Sena Technologies, Inc.

210 Yangjae-dong Seocho-gu

Seoul 137-130, Korea

Tel: (+82-2) 576-7362

Fax: (+82-2) 573-7710

Email: [support@sena.com](mailto:support@sena.com)

Website: <http://www.sena.com>

Revision	Date	Name	Description
V1.0.0	2011-08-22	HR Zo	Initial Writing
V1.0.1	2011-09-29	HR Zo	Modification for ZE20S PTv1.4 - Adding AT+RSSI Command
V1.0.2	2011-11-16	HR Zo	Modification of errors at 6.1 Development Kit Contents
V1.5	2012-02-21	Uin Bum	Modification for ZE20S PTv1.5 - Modification of the ATS11 and flow control default value - Adding ATS71 Register for Frequency Agility Modification of Key Features about power and current Modification of default function at Pin Assignment Table Modification of Working Distance Modification of Overview
V1.6	2012-08-20	Uin Bum	Modification of Mechanical Drawings. Modification of ATS55 information. Modification of some mistypes.
V1.7	2013-04-09	Uin Bum	Modification of Analog GPIO information. Modification of Permit Join and Factory Reset button information. - Changes rising edge to falling edge
V1.7.1	2013-07-17	Uin Bum	Modification for GPIO_14 pin information.
V1.8	2013-08-28	Uin Bum	Modification for ATS36 input range. Modification for Multicast information. Modification for Factory_reset button information.
V1.9	2013-10-31	Uin Bum	Fixed mistype AT+AIO to AT+AI in 5.2.1. Modification for Multicast information.
V1.10	2014-02-14	Uin Bum	Modification for 11.1 Serial Port Pin Outs. Modification for Analog GPIO return value range in 5.2.1 and 6.6.7.1. Modification for 4.1.1 Unicast

## Contents

<b>1</b>	<b>INTRODUCTION.....</b>	<b>11</b>
1.1	About This Document.....	11
1.2	Overview .....	11
<b>2</b>	<b>GETTING STARTED.....</b>	<b>13</b>
2.1	Hardware Installation.....	13
2.1.1	<i>Development Board Layout.....</i>	<i>13</i>
2.1.2	<i>Antenna Installation .....</i>	<i>14</i>
2.1.3	<i>Module Installation on the Development Board.....</i>	<i>14</i>
2.1.4	<i>Serial/USB Cable Installation.....</i>	<i>15</i>
2.1.5	<i>Powering Development Board .....</i>	<i>16</i>
2.1.6	<i>USB Driver Installation.....</i>	<i>16</i>
2.2	Using Terminal Software for AT Commands.....	17
2.3	Using ProBee Manager for Configuration.....	18
2.3.1	<i>Serial Port Open.....</i>	<i>18</i>
2.3.2	<i>Configuration .....</i>	<i>19</i>
2.3.3	<i>Firmware Update.....</i>	<i>21</i>
<b>3</b>	<b>ZIGBEE NETWORK CONFIGURATION.....</b>	<b>23</b>
3.1	Setting up ZE20S as a Coordinator .....	23
3.1.1	<i>Node Type Selection for Coordinator .....</i>	<i>24</i>
3.1.2	<i>Channel Mask Configuration for Coordinator .....</i>	<i>24</i>
3.1.3	<i>PAN ID Configuration for Coordinator.....</i>	<i>25</i>
3.1.4	<i>Permit Joining.....</i>	<i>25</i>
3.2	Setting up ZE20S as a Router.....	26
3.2.1	<i>Node Type Selection for Router.....</i>	<i>26</i>
3.2.2	<i>Channel Mask Configuration for Router.....</i>	<i>27</i>
3.2.3	<i>PAN ID Configuration for Router.....</i>	<i>27</i>
3.2.4	<i>Permit Joining.....</i>	<i>27</i>
3.3	Setting up ZE20S as an End-Device .....	28
3.4	Setting up ZE20S as a Sleepy End-Device .....	29
3.5	ZigBee Security .....	30
3.5.1	<i>Security Level.....</i>	<i>31</i>
3.5.2	<i>Link Key.....</i>	<i>31</i>
3.5.3	<i>Network Key.....</i>	<i>31</i>
3.5.4	<i>Update Key.....</i>	<i>31</i>



3.6	Frequency Agility .....	31
<b>4</b>	<b>DATA TRANSMISSION.....</b>	<b>33</b>
4.1	Command Mode .....	33
4.1.1	Unicast.....	33
4.1.2	Multicast.....	34
4.1.3	Broadcast .....	34
4.1.4	Sending Binary Data.....	35
4.1.5	Display Incoming Message .....	35
4.2	Data Mode.....	36
4.2.1	Unicast Data Mode .....	36
4.2.2	Multicast Data Mode .....	39
4.2.3	Broadcast Data Mode.....	41
<b>5</b>	<b>DIGITAL AND ANALOG I/O.....</b>	<b>43</b>
5.1	GPIO (General Purpose Inputs and Outputs) Configuration .....	43
5.2	I/O Sampling .....	44
5.2.1	Queried Sampling .....	44
5.2.2	Periodic Sampling.....	46
5.2.3	Change Detection Sampling .....	47
5.2.4	GPIO Remote Control.....	47
<b>6</b>	<b>WORKING WITH DEVELOPMENT KIT .....</b>	<b>48</b>
6.1	Development Kit Contents .....	48
6.2	Development Board Features.....	48
6.3	Development Board Hardware Descriptions .....	49
6.3.1	Power.....	49
6.3.2	RS232 Port.....	49
6.3.3	USB Port.....	50
6.3.4	ZE20S GPIO Interface.....	50
6.3.5	LEDs (CR12-19).....	51
6.3.6	Button Switches (SW10-17).....	51
6.3.7	Variable Resistors (VR1, VR2).....	51
6.3.8	Temperature Sensor.....	51
6.3.9	Light Sensor.....	52
6.3.10	Terminal Block.....	52
6.4	Configuration Example #1: 1 Coordinator, 1 Router and 1 End-Device.....	52
6.4.1	Coordinator Configuration .....	53
6.4.2	Router Configuration.....	53
6.4.3	End-device Configuration.....	54

6.4.4	<i>Monitoring the Sensors</i> .....	54
6.5	Configuration Example #2: 1 Coordinator and 2 End-Devices .....	55
6.5.1	<i>Coordinator Configuration</i> .....	55
6.5.2	<i>End-devices Configuration</i> .....	55
6.5.3	<i>Turning on/off the LEDs</i> .....	56
6.6	Configuration Example #3: Light Sensor and Temperature Sensor .....	56
6.6.1	<i>Coordinator Configuration</i> .....	56
6.6.2	<i>Router Configuration</i> .....	57
6.6.3	<i>Applying</i> .....	58
6.6.4	<i>Queried Sampling</i> .....	59
6.6.5	<i>Periodic Sampling – Destination Node</i> .....	60
6.6.6	<i>Periodic Sampling – Sink Node</i> .....	61
6.6.7	<i>Data Conversion</i> .....	62
<b>7</b>	<b>AT COMMAND REFERENCE</b> .....	<b>64</b>
7.1	Command Line Format .....	64
7.2	Standard AT Commands .....	64
7.2.1	<i>AT</i> .....	64
7.2.2	<i>ATB</i> .....	64
7.2.3	<i>ATD</i> .....	64
7.2.4	<i>ATE</i> .....	65
7.2.5	<i>ATM</i> .....	65
7.2.6	<i>ATO</i> .....	65
7.2.7	<i>ATR</i> .....	65
7.2.8	<i>ATS</i> .....	65
7.2.9	<i>ATZ</i> .....	65
7.2.10	<i>AT&amp;F</i> .....	65
7.2.11	<i>+++</i> .....	66
7.3	Node Specific Information.....	66
7.3.1	<i>AT+LONGADDR or AT+LA</i> .....	66
7.3.2	<i>AT+SHORTADDR or AT+SA</i> .....	66
7.3.3	<i>AT+ADDRDISCOVERY or AT+AD</i> .....	66
7.3.4	<i>AT+OPCH or AT+OC</i> .....	66
7.3.5	<i>AT+OPPANID or AT+OI</i> .....	67
7.3.6	<i>AT+OPEPID or AT+OE</i> .....	67
7.3.7	<i>AT+VERSION or AT+VR</i> .....	67
7.3.8	<i>AT+PRODUCTNAME or AT+PN</i> .....	67
7.4	Network Specific Parameters .....	67
7.4.1	<i>AT+CHMASK or AT+CM</i> .....	67
7.4.2	<i>AT+PANID or AT+PI</i> .....	68

7.4.3	<i>AT+EPID or AT+EI</i> .....	68
7.4.4	<i>AT+GROUPIP or AT+GI</i> .....	68
7.4.5	<i>AT+POWER or AT+PW</i> .....	68
7.4.6	<i>AT+STACK or AT+ZS</i> .....	69
7.4.7	<i>AT+NODENAME or AT+NN</i> .....	69
7.5	Network Formation and Join .....	69
7.5.1	<i>AT+ASCAN or AT+AS</i> .....	69
7.5.2	<i>AT+ESCAN or AT+ES</i> .....	69
7.5.3	<i>AT+DSCAN or AT+DS</i> .....	70
7.5.4	<i>AT+RSSI or AT+RS</i> .....	70
7.5.5	<i>AT+NODETYPE or AT+NT</i> .....	70
7.5.6	<i>AT+PERMIT or AT+PJ</i> .....	71
7.5.7	<i>AT+LEAVE or AT+LV</i> .....	71
7.6	End-device .....	71
7.6.1	<i>AT+SLEEP or AT+SM</i> .....	71
7.6.2	<i>AT+PARENTLA or AT+PL</i> .....	71
7.6.3	<i>AT+PARENTSA or AT+PS</i> .....	71
7.6.4	<i>AT+CHILDTABLE or AT+CT</i> .....	71
7.7	Data Transmission and Reception .....	72
7.7.1	<i>AT+DESTLA or AT+DL</i> .....	72
7.7.2	<i>AT+DESTGROUPIP or AT+DG</i> .....	72
7.7.3	<i>AT+SINKINFO or AT+SI</i> .....	72
7.7.4	<i>AT+MAXPAYLOAD or AT+MP</i> .....	72
7.7.5	<i>AT+TRASNSMITMODE or AT+TM</i> .....	72
7.7.6	<i>AT+UNICAST or AT+UC</i> .....	73
7.7.7	<i>AT+MULTICAST or AT+MC</i> .....	73
7.7.8	<i>AT+BROADCAST or AT+BC</i> .....	73
7.7.9	<i>AT+REMOTE or AT+RC</i> .....	73
7.8	Security .....	73
7.8.1	<i>AT+SECURITY or AT+SE</i> .....	73
7.8.2	<i>AT+LINKKEY or AT+LK</i> .....	73
7.8.3	<i>AT+NWKEY or AT+NK</i> .....	74
7.8.4	<i>AT+UPDATEKEY or AT+UK</i> .....	74
7.9	UART .....	74
7.9.1	<i>AT+BAUDRATE or AT+UB</i> .....	74
7.9.2	<i>AT+DATABIT or AT+UD</i> .....	74
7.9.3	<i>AT+PARITY or AT+UP</i> .....	75
7.9.4	<i>AT+STOPBIT or AT+US</i> .....	75
7.9.5	<i>AT+FLOWCTRL or AT+UF</i> .....	75
7.10	GPIO .....	75

7.10.1	<i>AT+GPIO or AT+IO</i> .....	75
7.10.2	<i>AT+DIO</i> .....	76
7.10.3	<i>AT+AI</i> .....	76
7.10.4	<i>AT+ SOURCELA or AT+SL</i> .....	76
7.11	Firmware Upload and Help .....	76
7.11.1	<i>AT+BOOTLOAD or AT+BL</i> .....	76
7.11.2	<i>AT+HELP or AT+HP</i> .....	77
<b>8</b>	<b>AT COMMAND EXAMPLES</b> .....	<b>78</b>
8.1	Network configuration .....	78
8.1.1	<i>Coordinator</i> .....	78
8.1.2	<i>Router</i> .....	78
8.1.3	<i>End-device</i> .....	78
8.1.4	<i>Sleepy End-device</i> .....	78
8.1.5	<i>Specifying Network</i> .....	78
8.2	Data Transmission .....	79
8.2.1	<i>Command Mode</i> .....	79
8.2.2	<i>Data Mode</i> .....	80
8.3	Security .....	80
8.4	UART Settings .....	81
8.5	GPIO .....	81
8.6	Firmware Upload .....	82
8.6.1	<i>Local Node</i> .....	82
8.6.2	<i>Remote Node</i> .....	82
<b>9</b>	<b>S-REGISTERS</b> .....	<b>83</b>
9.1	Display Options .....	84
9.1.1	<i>S11</i> .....	84
9.1.2	<i>S12</i> .....	84
9.1.3	<i>S13</i> .....	84
9.1.4	<i>S14</i> .....	84
9.2	Network Settings .....	85
9.2.1	<i>S21</i> .....	85
9.2.2	<i>S22</i> .....	85
9.2.3	<i>S23</i> .....	85
9.3	Data Transmissions .....	85
9.3.1	<i>S31</i> .....	85
9.3.2	<i>S32</i> .....	86
9.3.3	<i>S33</i> .....	86
9.3.4	<i>S34</i> .....	86

9.3.5	S35.....	86
9.3.6	S36.....	87
9.3.7	S37.....	87
9.3.8	S38.....	87
9.3.9	S39.....	87
9.4	GPIO.....	88
9.4.1	S41.....	88
9.4.2	S42.....	88
9.4.3	S43.....	88
9.4.4	S44.....	89
9.4.5	S45.....	89
9.5	End-Device.....	89
9.5.1	S51.....	89
9.5.2	S52.....	89
9.5.3	S53.....	90
9.5.4	S54.....	90
9.5.5	S55.....	90
9.5.6	S56.....	90
9.6	Sink.....	91
9.6.1	S61.....	91
9.6.2	S62.....	91
9.7	Frequency Agility .....	91
9.7.1	S71.....	91
<b>10</b>	<b>PIN ASSIGNMENTS .....</b>	<b>92</b>
<b>11</b>	<b>CONNECTIONS.....</b>	<b>94</b>
11.1	Serial Port Pin Outs .....	94
11.2	Serial Wiring Diagram .....	95
11.2.1	To Host with DTE Interface .....	95
11.2.2	To Host with DCE Interface .....	95
<b>12</b>	<b>MECHANICAL DRAWINGS.....</b>	<b>96</b>
<b>13</b>	<b>WARRANTY.....</b>	<b>98</b>
13.1	GENERAL WARRANTY POLICY.....	98
13.2	LIMITATION OF LIABILITY.....	98
13.3	HARDWARE PRODUCT WARRANTY DETAILS .....	99
13.4	SOFTWARE PRODUCT WARRANTY DETAILS.....	99
13.5	THIRD-PARTY SOFTWARE PRODUCT WARRANTY DETAILS.....	99
<b>14</b>	<b>REGULATORY INFORMATION.....</b>	<b>100</b>

14.1	FCC.....	100
14.2	CE.....	101
14.3	TELEC.....	101
14.4	KCC.....	101
<b>15</b>	<b>RF INFORMATION.....</b>	<b>102</b>

# 1 Introduction

## 1.1 About This Document

This document provides an introduction on configuration and operation of the ProBee-ZE20S ZigBee OEM module. This document assumes the user is using the ZE20S starter kit for evaluation hence the pictures and configuration examples shown in this document are all based on the ZE20S starter kit.

This document does not provide full detail of the hardware specifications. Please refer to the ProBee-ZE20S data sheet for further references on the hardware design.

## 1.2 Overview

The ProBee-ZE20S is an all-in-one ZigBee OEM module with integrated ZigBee core and radio/antenna circuits together with high level software library. Using the ZE20S, OEM manufacturers can easily and cost-effectively integrate ZigBee functionality into target products in timely manner.

The ZE20S OEM module is designed to meet specific requirements of low cost and low power wireless applications such as Home Automation, Smart Energy, Health care, Building Automation and Telecom Services by adopting the ZigBee technology. The ZE20S is based on the Ember EM357 ZigBee core and certified ZigBee Alliance based on ZigBee 2007 and ZigBee Pro stack.

Despite of its low cost and low power consumptions, the ZE20S provides high performance and robust data transfer capability for wide range of applications. The ZE20S can transfer data at up to 250 kbps and reach up to 300 m (0.19 miles) outdoor line-of-sight.

### Key Features

- Integrated 2.4GHz, IEEE 802.15.4-2003 compliant transceiver
- ZigBee 2007 / ZigBee Pro stack
- ZigBee core: Ember EM357
- Transmit Power: +8dBm (Boost mode)
- Receiver Sensitivity: -102dBm @1% BER (Boost mode)
- Supply Voltage: 2.1~3.6 VDC
- TX Current: 45mA @3.3V (max.)
- RX Current: 31mA @3.3V (max.)
- Sleep Current:  $\leq 1\mu\text{A}$
- Working Distance: 300 m (0.19 miles) @ 3.3V, +5dBi Dipole Antenna
- Various Antenna/Connector Options: Dipole 1/3/5dBi, U.FL, RPSMA, Chip
- UART Signals Support: UART\_TXD/RXD, RTS/CTS, DTR/DSR
- 6 Analog Inputs
- 17 Digital Inputs/Outputs

- RoHS Compliant

**Applications**

- Advanced Metering Infrastructure
- Home Area Networks (HAN)
- Neighborhood Area Networks (NAN)
- Home Automation
- Advanced lighting, entertainment and climate control systems
- Service-based monitoring, security and awareness systems
- Commercial Building Automation
- Climate & lighting control systems
- Industrial and Domestic Applications



## 2 Getting Started

Creating a ZigBee network using the ZE20S modules consists of the following steps:

- Install the ZE20S module on the development board
- Create a ZigBee network by configuring a ZE20S module as the coordinator
- Configure ZE20S modules as routers. This step is optional since the coordinator works as a router too.
- Configure ZE20S modules as end-devices
- Transmit data between ZE20S devices

This chapter describes how to install the ZE20S modules on to the development boards and how to use terminal software programs to access the ZE20S modules using AT commands for configurations and operations. The rest of the steps including ZigBee network creation, coordinator/router/end-device configurations and data transmissions are described in the following chapters. The more detailed information on the starter kit and the configuration examples are also provided in the later chapter.

### 2.1 Hardware Installation

#### 2.1.1 Development Board Layout

Figure 2-1 shows the layout of the development board. The development board provides the interface between the ZE20S and the external serial port or USB port together with input/output terminals for convenient tests.

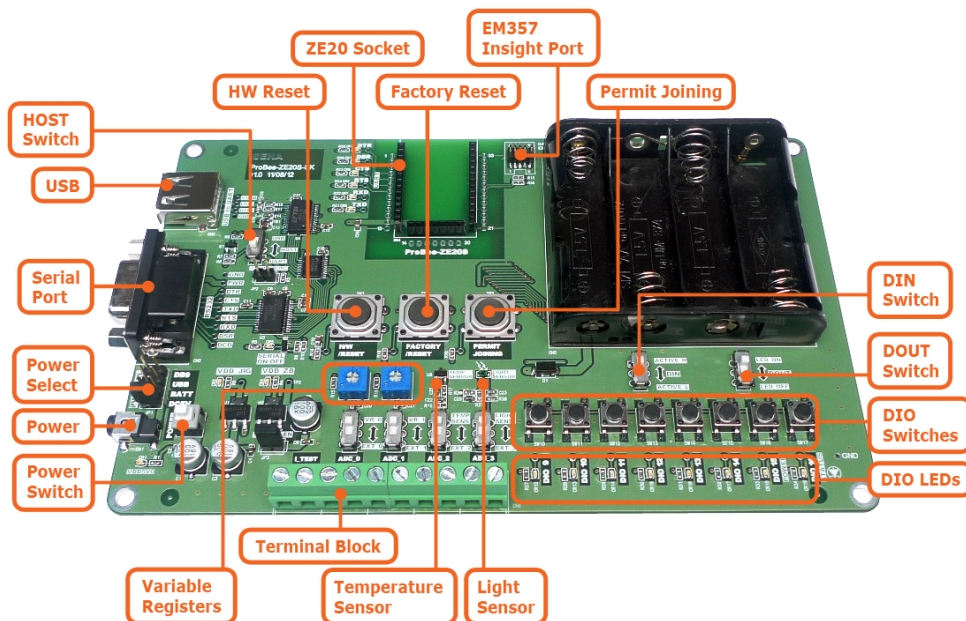

Figure 2-1 Development Board Layout

### 2.1.2 Antenna Installation

The ZE20S starter kit includes the several antennas for evaluation purposes. You can try different antennas for testing purpose and select the appropriate antenna for the actual applications. Figure 2-2 shows how to install the RP-SMA dipole antenna to the ZE20S module.



Figure 2-2 RP-SMA Dipole Antenna Installation

### 2.1.3 Module Installation on the Development Board

Once the antenna is installed on the ZE20S module, the ZE20S module can be installed on the development board.

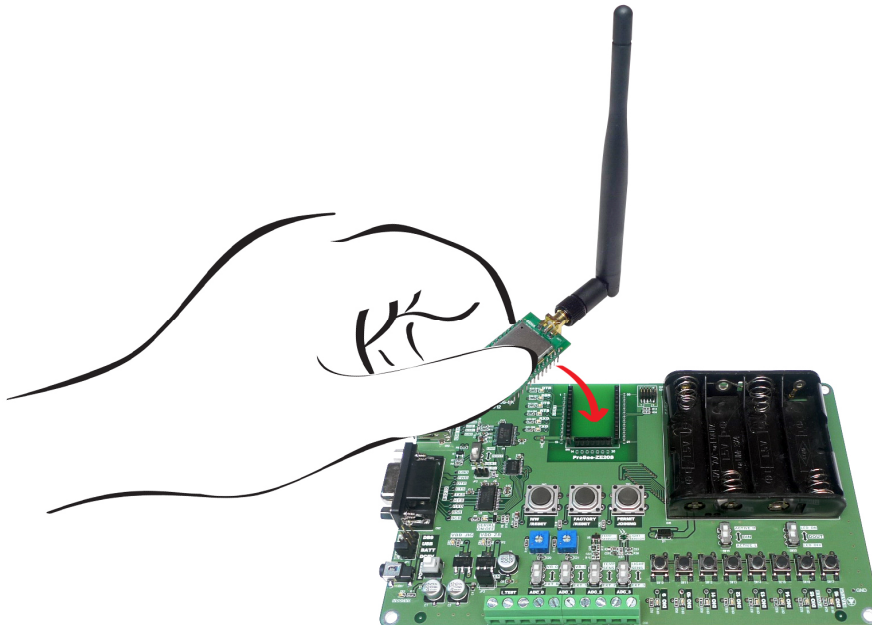

Figure 2-3 ZE20S Installation on the Development Board

### 2.1.4 Serial/USB Cable Installation

After the ZE20S is securely installed on the development board, please connect the included serial cable between the development board and your computer so AT commands can be sent from the computer to the ZE20S module. The serial port of the development board is DB9 female as a DTE terminal, and the serial cable included is a cross-over cable for DTE-DTE connection. To use the serial port, the HOST (SW2) switch should be set to UART.

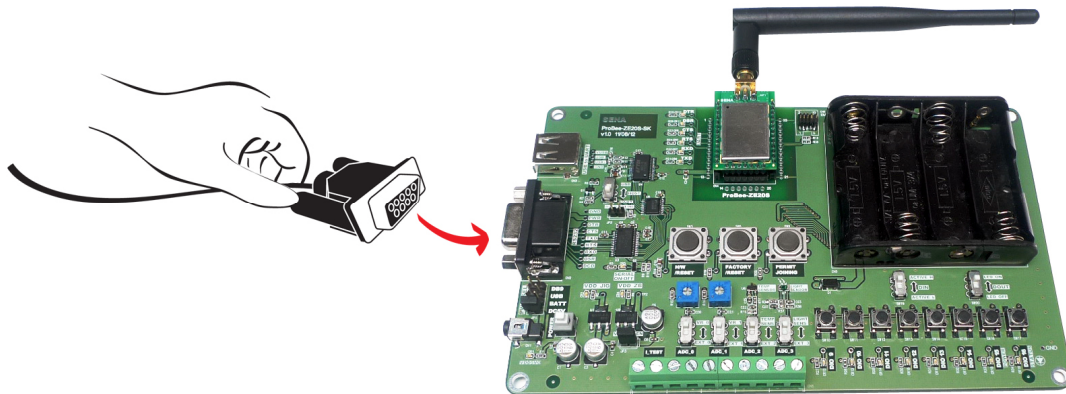

Figure 2-4 Serial Cable Installation

In case the serial port is not available for the computer, you can use the USB port of the development board instead. In this case, the internal USB-RS232 converter of the development board will convert the USB signal to the RS232 signal and vice versa. To use the USB port, the HOST (SW2) switch should be set to USB and the software driver for the USB in the CD should be installed on the computer. For the USB driver installation, please refer to the section 2.1.6.

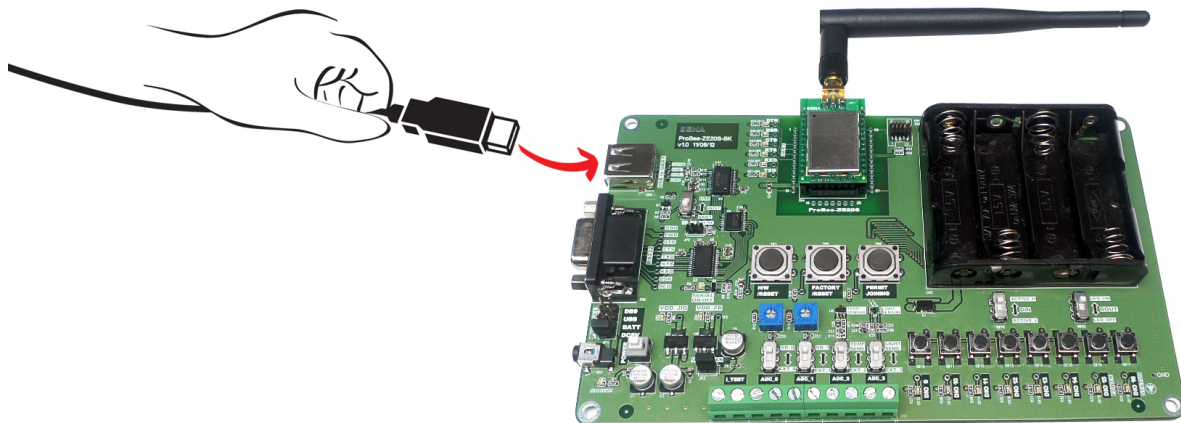

Figure 2-5 USB Cable Installation

### 2.1.5 Powering Development Board

Once all the installations are completed, please plug in the power connector using the included DC power adapter. The RS\_PWR, USB\_PWR and BATT\_EN jumpers should be all OPEN to use the DC power adapter. Alternatively, the development board can be powered using batteries, or from the USB port or through the RS232 port pin 9. In these cases, the power source jumpers should be set accordingly. For details about the power source jumper settings, please refer to the section **6.3.1 Power**.

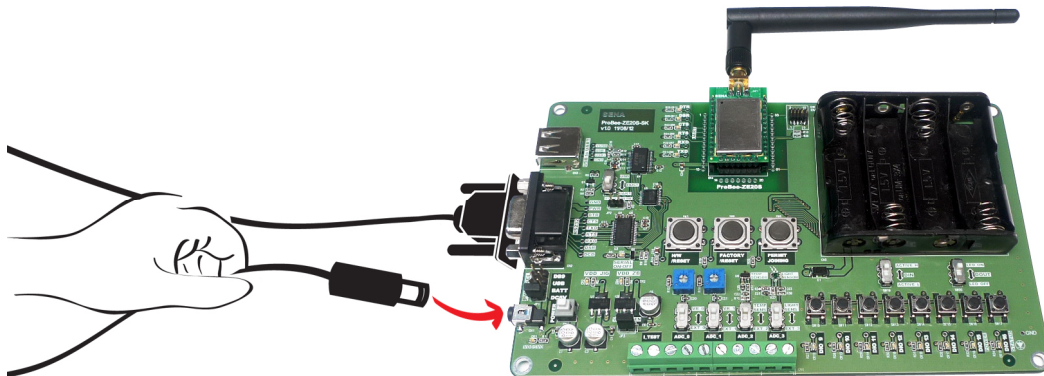

Figure 2-6 Plugging DC Power Adapter

### 2.1.6 USB Driver Installation

In case the USB interface is used for the communication between the development board and the computer, the corresponding software driver needs to be installed on the computer. Windows XP and later versions already include the USB driver. When Windows asks for the location of the USB driver, you can select the option to “install the software automatically” as shown in Figure 2-7. You can also choose to install the driver from the CD included if the driver is not installed correctly for some reason.

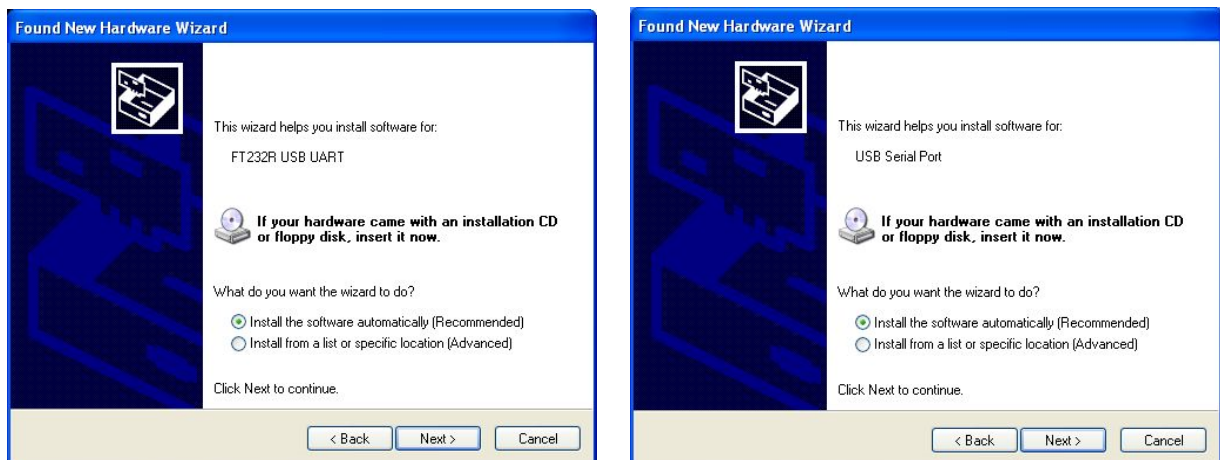

Figure 2-7 USB Driver Installation

## 2.2 Using Terminal Software for AT Commands

Once the hardware installation is complete, the ZE20S unit is ready to communicate with the computer using the AT commands using a terminal emulation software. You can use any kind of terminal emulation software. This document assumes HyperTerminal is used. If you are using Windows Vista or 7, HyperTerminal is no longer included in the Windows so you need to download HyperTerminal from the Internet. For more details on HyperTerminal, please refer to Microsoft web page.

Once the HyperTerminal is installed, launch HyperTerminal and select the serial port that is connected to the ZE20S development board and enter the serial settings to use. The default serial settings of the ZE20S are **9600 bps, 8 data bit, none parity, 1 stop bit, none flow control**.

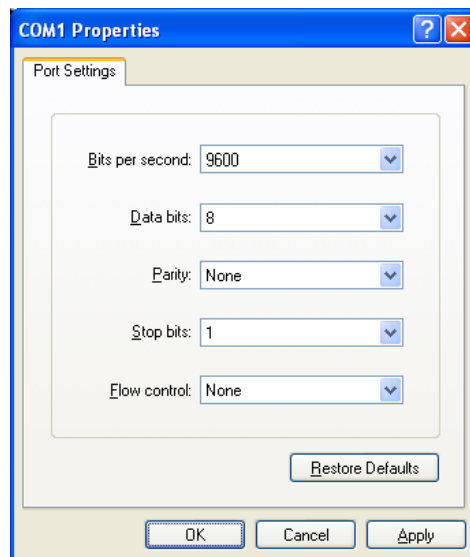

Figure 2-8 HyperTerminal Serial Settings

To display the AT commands that are being typed, you need to enable the local echo option on the HyperTerminal. To enable this option, Go to File->Properties->Settings->ASCII setup and select the "Echo typed characters locally" option. To verify the connection, type AT and press the Enter key. If the AT command is accepted by the ZE20S, OK string will be displayed on the screen.

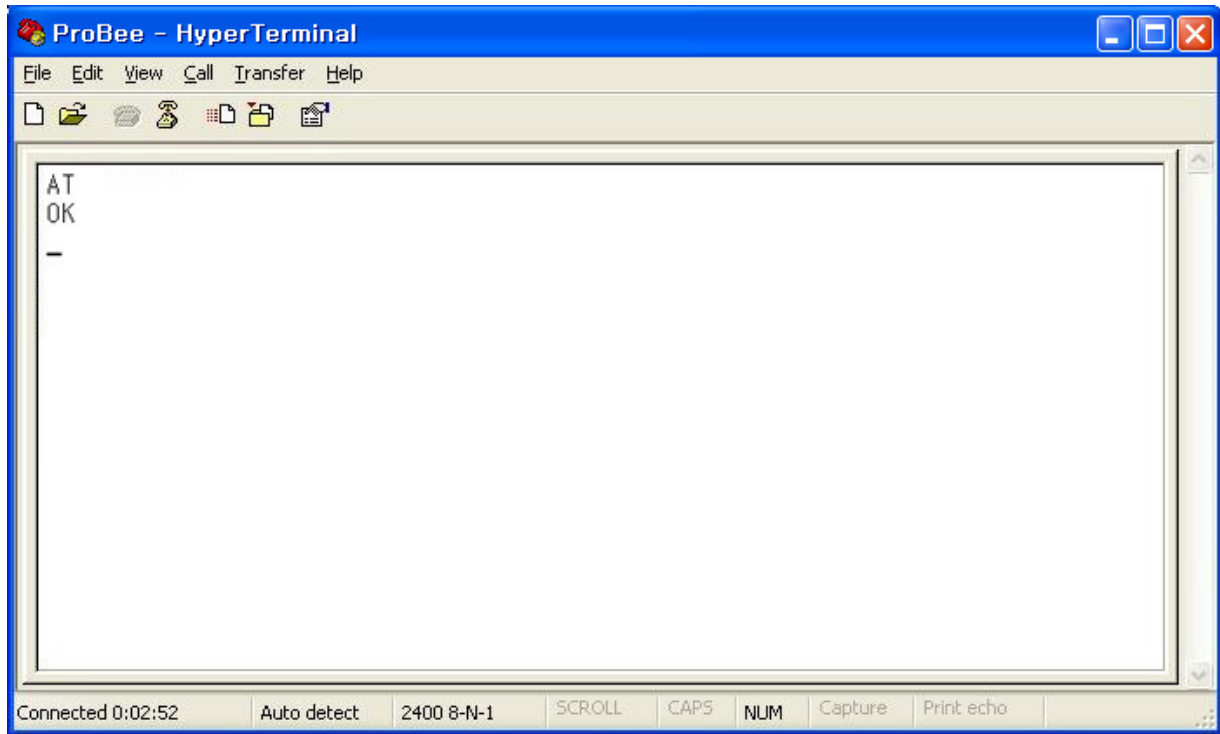

Figure 2-9 Testing AT Command on HyperTerminal

## 2.3 Using ProBee Manager for Configuration

It is possible to set or get the configurations of the ZE20S using ProBee Manager. This PC utility helps that a user can configure several setting values of local node and remote node easily without a terminal program. It is possible to export current configuration and import it to other nodes. It is also possible to restore to factory default configuration.

It provides users with functions to upgrade firmware of not only local node but also remote node.

### 2.3.1 Serial Port Open

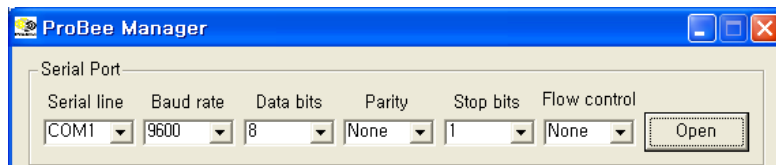

Figure 2-10 ProBee Manager Serial Port Open

To connect to local node through serial port, please follow the steps as below:

- Set 'Serial Port' properties corresponding to the UART configuration of local node.
- Click 'Open' button.

ProBee manager displays the main window like Figure 2-11 after connecting to local node.



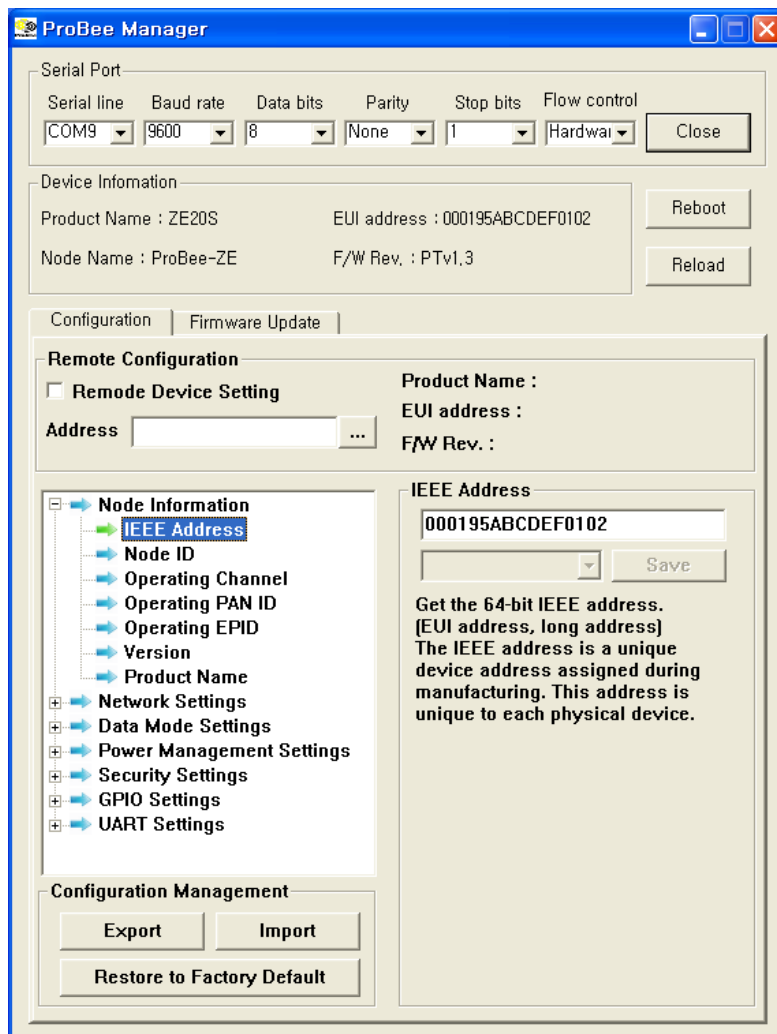

Figure 2-11 ProBee Manager Main Window

Clicking 'Reboot' button reboots the local node. Users can reload and refresh the recent configuration of the local node at ProBee manager by clicking 'Reload' button. 'Configuration' tab and 'Firmware Update' tab can help move to the 'Configuration' screen and the 'Firmware Update' screen.

### 2.3.2 Configuration

The Configuration Pane appears when the 'Configuration' tab is selected.

To change configuration, users need to find and modify the property and then apply changes. The properties are categorized according to the function. Selecting a category unfolds or folds the property list. The name, the current value and the description of the property are shown at the right of the configuration pane by selecting a property in the property list. It is possible to edit and save the current value of editable property. Whenever property is modified, it is necessary to save the change by clicking the 'Save' button

in order not lose it moving to other properties. To apply changes, please reboot the device by clicking 'Reboot' button. The 'Save' button is disabled for read-only property.

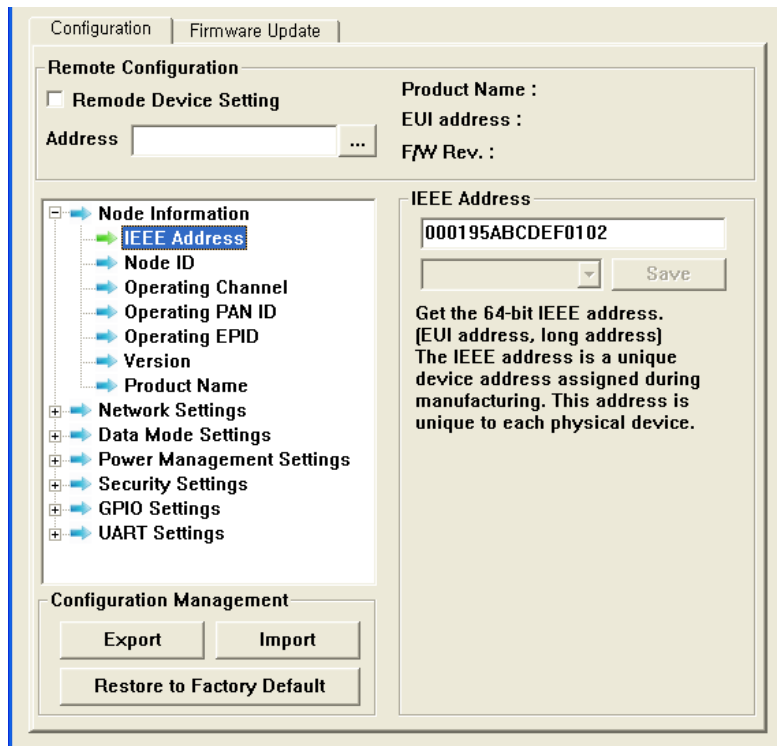

Figure 2-12 ProBee Manager Configuration Pane

In Figure 2-12, the 'Node Information' category is selected and the 'IEEE Address' property is selected, so its description is displayed. The 'Save' button is disabled because the 'IEEE Address' property is read-only.

The configurations of the remote nodes joining the network where the local node belongs can be modified, too. Because a sleepy end-device often enters sleep mode, to remote configuration from a sleepy end-device may not work.

To connect to local node through serial port, please follow the steps as below:

- Click the '.' button at 'Remote Configuration' section.
- Scan the remote nodes joining the network and select the remote node to configure, that results in displaying the remote node in the 'Address' edit box.
- Check the 'Remote Device Setting' check box and the caption of the 'Restore to Factory Default' button at the 'Configuration Management' section becomes 'Reboot' that makes the remote node reboot and configuration of the selected node is displayed.
- Select and modify the property.
- Click the 'Save' button.



- Click the 'Reboot' button whose caption used to be 'Restore to Factory Default' to apply changes.

To export the configuration, please follow the steps as below:

- Click the 'Export' button at the 'Configuration Management' section and the 'Save As' dialog pops up.
- Select the path and enter the file name to store the configuration at.
- Click the 'Save' button and the configuration is exported to the designated file.

Exported file can be used at other devices by importing them. The configuration of remote node can be exported and imported by checking the 'Remote Device Setting' check box.

Users can reset to factory default by clicking the 'Restore to Factory Default' at the 'Configuration Management' section.

### 2.3.3 Firmware Update

The screenshot shows the 'Firmware Update' pane in the ProBee Manager. It includes a 'Message' area for status updates, a 'Firmware File' section for selecting files from a local PC or downloading from a web server, and sections for updating local and remote devices. A table for remote device updates lists columns for Type, IEEE Address, Version, ModelType, NodeName, and Progress. Search and update controls are located at the bottom.

Figure 2-13 ProBee Manager Firmware Update Pane

The Firmware Update Pane appears when the 'Firmware Update' tab is selected. The 'Message' section displays informative message about the progress of updating firmware.

To update firmware at local node, please follow the steps as below:

- Select a firmware file to update at the 'Firmware Update' section. The 'Choose file in local PC' button pops up the dialog where users can select the firmware file at local PC and the 'Download from web server' button helps users download the firmware from web server.
- Click the 'Update' button at the 'Device Update' section to update the local node. The progress rate is expressed at the 'Local Device Update' section and informative messages are shown at 'Message' section.

ProBee Manager also supports to update the firmware of remote nodes which join the network where local node is. Because a sleepy end-device often enters sleep mode, to update remote node from a sleepy end-device may not work.

To update firmware at remote node, please follow the steps as below:

- Select a firmware file.
- Click the 'Search' button, that scans the remote nodes joining the network where local node belongs.
- Select the remote nodes to update in the remote nodes list.
- Click the 'Update' button at the 'Remote Device Update' section.

### 3 ZigBee Network Configuration

A ZigBee Network consists of a coordinator, routers and end-devices. A minimal ZigBee network consists of one coordinator and multiple end-devices which directly connect to the coordinator. For larger ZigBee networks, routers are required to provide redundant routings to form mesh networks.

- **ZigBee Coordinator:** The coordinator forms the root of the network tree and might bridge to other networks. There is exactly one ZigBee coordinator in each network since the coordinator starts the ZigBee network itself. It also stores information about the network, including acting as the Trust Center & repository for security keys.
- **ZigBee Router:** The routers are able to route messages between other devices. Since the coordinator provides the routing functionality too, the routers are optional to form a ZigBee network.
- **ZigBee End-Device:** The end-device contains just enough functionality to talk to the parent node which is either the coordinator or a router. It cannot relay data from other devices.
- **ZigBee Sleepy End-Device:** The sleepy end-device is the same with normal end-device except it can stay in the sleep mode much longer. This relationship allows the end-device to sleep significant amount of the time and achieve the long battery life.

The ZE20S can be configured to work either as a coordinator, a router, an end-device or a sleepy end-device. Once the operation mode of the ZE20S is selected, corresponding parameters need to be set up appropriately. This chapter explains how to configure the ZE20S operation mode and other parameters related to the ZigBee network itself.

*Table 3-1 ZigBee Node Types*

Node Type	Recommendation when to use ZE20S
Coordinator	It should be selected when it is first time to establish the network.
Router	It is recommended when there is a network already and it needs to be expanded. A router is suitable for fast and stable data transmissions and receptions.
End-Device	It is recommended when it doesn't need to expand the network anymore and there are enough nodes as parents. An end-device consumes less power than a router.
Sleepy End-Device	It is recommended when the data transmissions occur rarely and in very small quantities. A sleepy end-device can lose data if sleep duration is too long, but it is possible to consume extremely low power as low as 2uA.

#### 3.1 Setting up ZE20S as a Coordinator

A coordinator relays messages and can act as a parent to other nodes. Every personal area network (PAN) must be started by a node acting as the coordinator. In general, this device is always powered on.

To set up the ZE20S to work as the coordinator, please follow the steps as below

- Configure the ZE20S node type as the coordinator
- Optionally, select the channel mask. Otherwise, the ZE20S will use the default channel mask.
- Optionally, set up the PAN ID and/or the extended PAN ID. Otherwise, the ZE20S will generate the PAN ID and/or the extended PAN ID automatically.
- Permit joining when other router or end-device tries to join the ZigBee network.

### 3.1.1 Node Type Selection for Coordinator

The ZE20S module can be configured as a ZigBee coordinator by the AT command as below:

*AT+NODETYPE=n or AT+NT=n*

*, where n is 0 = none, 1 = coordinator, 2 = router, 3 = end-device, 4 = sleepy end-device*

After the operation mode is selected, ATZ command should be performed to reset the unit to have the change applied.

Example)

```
AT+NODETYPE=1<CR>      # Set node type as the coordinator
OK<CR>                 # Response
ATZ<CR>                # Apply the change
OK<CR>                 # Response
```

### 3.1.2 Channel Mask Configuration for Coordinator

When the ZigBee coordinator starts, it scans predefined frequency channels to find the best frequency channel to use without causing interference with other wireless devices. The user is able to specify the channels to use with the AT command as below:

*AT+CHMASK=n or AT+CM=n*

*, where n = channel mask to use. Default = 0x07FFF800*

This value has a 32-bit hexadecimal unsigned integer. Each bit represents whether a channel will be used or not. For example, to use a channel between 12 and 15, the 12, 13, 14 and 15 bits of the channel mask should be 1 and all other bits should be 0. The default setting is 0x7FFF800 which means that all the channels from 11 to 26 can be used. The ZE20S supports only the channels between 11 and 26, so 0~10 bits and 27~31 bits should be 0. Table 3-2 shows the bit mask for each channel.

Table 3-2 Channel Bitmask

Channel	11	12	13	14	15	16	17	18
Bit mask	00000800	00001000	00002000	00004000	00008000	00010000	00020000	00040000
Channel	19	20	21	22	23	24	25	26
Bit mask	00080000	00100000	00200000	00400000	00800000	01000000	02000000	04000000

### 3.1.3 PAN ID Configuration for Coordinator

Every ZigBee network should be assigned a PAN ID to identify the network. If the PAN ID is 0000, the ZE20S will generate a random 16-bit PAN ID to start the ZigBee network. Otherwise, the user can enter the PAN ID using the AT command as below:

*AT+PANID=xxxx or AT+PI=xxxx*

, where xxxx is PAN ID to use. For example, 12AB. Default setting is 0000

When choosing a PAN ID, the user needs to make sure that there is no ZigBee network using the same PAN ID. If the PAN ID is already used by another ZigBee network, the PAN ID is unavailable and the user should choose a new PAN ID. In order to avoid this, PAN ID auto-generation is strongly recommended.

The user can also assign the 64-bit extended PAN ID to the ZE20S using the AT command below. If the extended PAN ID is 0000000000000000, the ZE20S uses its IEEE address as the extended PAN ID. The extended PAN ID cannot be shared with other ZigBee networks, either.

*AT+EPID=xxx...xxx or AT+EI= xxx...xxx*

, where xxx...xxx is EPID to use. For example, 0123456789ABCDEF. Default setting is 000...000.

### 3.1.4 Permit Joining

When a router or an end-device tries to join the ZigBee network, there should be at least one coordinator or router which is permitting joining. If there is no router in the ZigBee network yet, the coordinator should permit joining. The ZE20S provides three ways to permit joining are as follows:

- Permanently permitting by configuration
- Transiently permitting by AT command
- Transiently permitting by digital input signal

If joining is permanently permitted, any device can join anytime. Since this will allow even an unidentified device to join the network anytime, this mode should be selected with extra caution. The AT command to permit joining permanently is as follows:

*AT+PERMIT=255 or AT+PJ=255*

The user can permit joining for a moment at need. The AT command to permit joining is

*AT+PERMIT=n or AT+PJ=n*

, where *n* is the duration to permit in seconds ranging 1~254 seconds.

The user can also configure the ZE20S to permit joining when the digital input GPIO0 is active. The AT command to enable this functionality is as follows:

*AT+GPIO0=5 or AT+IO0=5*

When the ZE20S detects falling edge of the GPIO0, the ZE20S permits joining for the duration that is configured in S-register 22 (S22). The AT command to change the duration is as follows:

*ATS22=n*

, where *n* is the duration to permit in seconds ranging 1~254 seconds. Default is 255.

S22 value determines the time that the device will allow other devices to join to it. If set to 255, the device will always permit other nodes joining. If the user reboots the coordinator (or a router), the device allows other nodes to join the network for the period defined by S-register 22.

*Note: When a device that has joined a network reboots, the device is able to join the network regardless of permitting. But, after the device has joined other network, rejoining the previous network should be permitted by the coordinator or a router.*

## 3.2 Setting up ZE20S as a Router

A router is a full-function routing device that relays messages and can act as a parent to other nodes. These devices must be always powered on.

To configure the ZE20S as a ZigBee router, please follow the steps below.

- Configure the ZE20S node type as a router.
- Optionally, select the channel mask. Otherwise, the ZE20S will use the default channel mask.
- Optionally, set up the PAN ID and/or the extended PAN ID. Otherwise, the ZE20S will scan and join the ZigBee network found automatically.
- Permit joining when other router or end-device tries to join the ZigBee network.

### 3.2.1 Node Type Selection for Router

The ZE20S module can be configured as a ZigBee router by the AT command as below:

*AT+NODETYPE=n or AT+NT=n*

, where *n* is 0 = none, 1 = coordinator, 2 = router, 3 = end-device, 4 = sleepy end-device

After the operation mode is selected, ATZ command should be performed to reset the unit to have the change applied.

Example)

```
AT+NODETYPE=2<CR>      # Select router mode
OK<CR>                 # Response
ATZ<CR>                # Apply the change
OK<CR>                 # Response
```

### 3.2.2 Channel Mask Configuration for Router

When the ZE20S as a ZigBee router or a ZigBee end-device tries to join, it scans all the channels configured by channel mask to find the ZigBee network to join. The channel mask of router or end-device should include the channel on which the coordinator is operating. On the assumption that the coordinator of the network to join is operating on channel 12, the router or end-device trying to join should have a channel mask of which 12<sup>th</sup> bit is 1.

### 3.2.3 PAN ID Configuration for Router

The PAN ID of a ZigBee router or a ZigBee end-device should be the same with the PAN ID of the ZigBee coordinator. If the coordinator is using a randomly generated PAN ID, the user can get the operating PAN ID by running the AT command below on the coordinator:

*AT+OPPANID or AT+OI*

If the PAN ID of a ZigBee router or a ZigBee end-device is 0000, the PAN ID is ignored. After checking the PAN ID, the ZE20S trying to join compares the extended PAN ID to make sure whether the network is the right network to join. If the extended PAN ID is the same with its configured extended PAN ID, it will try to join the network. Otherwise, it will try to find another network. The user can get the operating extended PAN ID by running the AT command below on the coordinator:

*AT+OPEPID or AT+OE*

If the extended PAN ID of a ZigBee router or a ZigBee end-device is 0000000000000000, the extended PAN ID is ignored

### 3.2.4 Permit Joining

The ZigBee router is configured and works the same way with the coordinator to permit joining of other nodes. Please refer to the section **3.1.4 Permit Joining** for the configuration.

### 3.3 Setting up ZE20S as an End-Device

An end-device is a leaf node which communicates only with its parent node and will not relay messages directly. To configure the ZE20S as a ZigBee end-device, please follow the steps below.

- Configure the ZE20S node type as an end-device
- Optionally, select the channel mask. Otherwise, the ZE20S will use the default channel mask.
- Optionally, set up the PAN ID and/or the extended PAN ID. Otherwise, the ZE20S will scan and join the ZigBee network found automatically.
- Configure the poll timeout and the poll period

Please refer to the section **3.2 Setting up ZE20S as a Router** for the AT commands regarding the node type selection, the channel mask configuration and the PAN ID/Extended PAN ID configuration.

When an end-device joins the network, the power LED blinks periodically if GPIO15 is set to specific functionality. The end-device belongs to a parent node which is either the coordinator or a router, and the parent node registers the end-device to its internal child table for message relaying. This table is maintained as long as the end-device polls the parent node periodically within the poll timeout value of the parent node. If the end-device does not poll for the poll timeout value of the parent node, the parent node removes the end-device from its child table and does not relay the message any more. Hence, the poll period of the end-device should be equal or shorter than the poll timeout of the parent node to avoid accidental removal of the end-device from the parent node's child table.

The ZE20S poll interval can be configured by setting the S-registers using the AT commands as below.

*ATS51=n, where n is poll timeout in seconds and the default is 60.*

This value is for a parent node. If an end-device does not send a poll request to its parent coordinator or router within the poll timeout, the end-device is removed from the child table.

*ATS56=n, where n is poll period in seconds and the default is 5.*

End-device polls the parent node at poll period defined by S56 periodically. It is for the connection to the parent node and data transmission with other nodes in the network.

*ATS55=n, where n is rejoin timeout and the default is 10.*

When the connection to the parent node is broken for S55 in seconds, the child node tries to rejoin the current network.

Even though the end-device needs to poll the parent node continuously, it does not go into the sleep mode and it can send and receive messages any time unlike the sleepy end-device.



### 3.4 Setting up ZE20S as a Sleepy End-Device

A sleepy end-device can turn off radio to save power. To configure the ZE20S as a ZigBee sleepy end-device, please follow the steps below.

- Configure the ZE20S node as a sleepy end-device.
- Optionally, select the channel mask. Otherwise, the ZE20S will use the default channel mask.
- Optionally, set up the PAN ID and/or the extended PAN ID. Otherwise, the ZE20S will scan and join the ZigBee network found automatically.
- Configure the settings for sleep interval.

Please refer to the section **3.2 Setting up ZE20S as a Router** for the AT commands regarding the node type selection, the channel mask configuration and the PAN ID/Extended PAN ID configuration.

One of the unique features of the ZigBee device is its extreme low power consumption which is mainly achieved by its efficient sleep and wake-up mechanism. While ZigBee coordinator and routers are required to be in operation all the time, ZigBee sleepy end-devices can be configured to be in the sleep mode most of the time and only wake up at pre-configured time interval for data transmission before it goes into the sleep mode again. The ZE20S sleep interval can be configured by setting the S-registers using the AT commands as below.

*ATS51=n, where n is poll timeout in seconds and the default is 60.*

This value is for a parent node. If a sleepy end-device does not send a poll request to its parent coordinator or router within the poll timeout, the sleepy end-device is removed from the child table.

Unlike the non-sleepy end-device, sleepy end-device does not use S56 as the poll period. Instead, it uses S53 as the sleep duration which works similar to the poll period, except it goes to sleep mode.

*ATS53=n, where n is sleep duration in quarter seconds and the default is 8.*

The ZE20S sleeps for sleep duration and turns off radio.

*ATS52=n, where n is poll period in milliseconds and the default is 100.*

Sleepy end-device wakes up from the sleep mode if S53 timer expires or GPIO0 interrupt is generated or serial data is received. Once the sleepy end-device wakes up, it polls the parent node at poll period defined by S52 until it goes to sleep mode again. Since the sleepy end-device exchanges data with the parent node only by polling, S52 poll period is usually configured as around 100 ms.

*ATS54=n, where n is standby timeout in seconds and the default is 5.*

If there is no RF data or serial data for S54 seconds, the sleepy end-device goes to sleep mode again. If any serial or RF data is sent or received, the timer will reset and the sleepy end-device waits for another S54 seconds before it goes to sleep mode again.

$ATS55=n$ , where  $n$  is rejoin timeout and the default is 10.

When the connection to the parent node is broken for S55 in seconds, the child node tries to rejoin the current network.

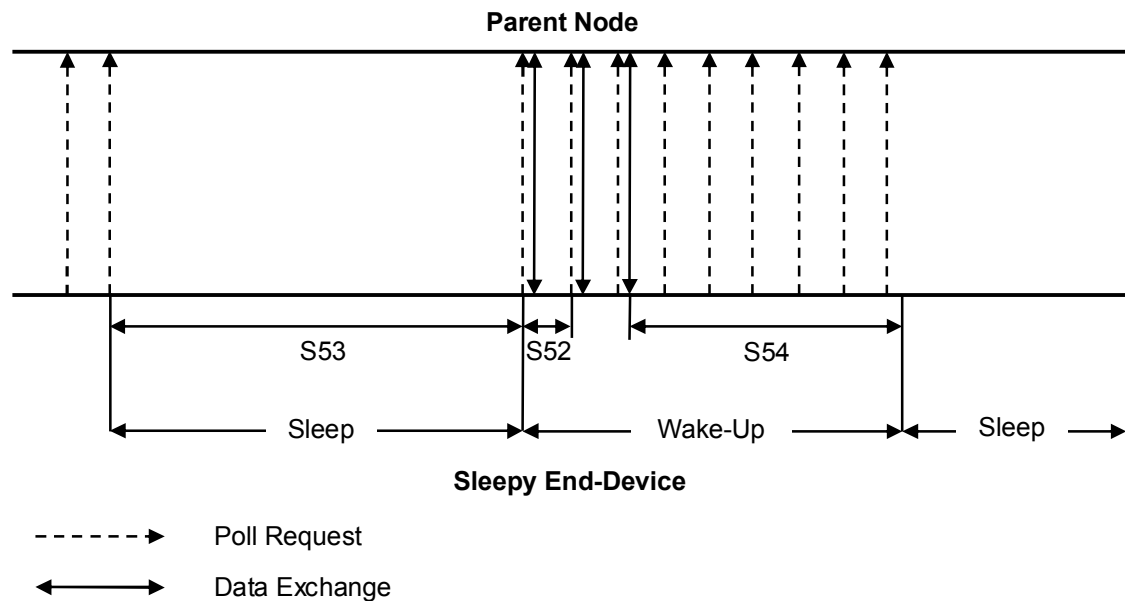

Figure 3-1 Sleep Interval and Wake-up Timing

The sleepy end-device can also wake up from the sleep mode by GPIO0 interrupt or incoming serial data. Once it wakes up, it also polls with the parent node at S52 interval and goes into sleep mode after S54 time elapses after the last data exchange.

*Note: If the sleepy end-device wakes up by incoming serial data, the integrity of the first incoming byte is not guaranteed. It is strongly recommended to wake up the sleepy end-device by using GPIO0 first before sending the serial data or use higher level serial data protocol to check the data integrity.*

### 3.5 ZigBee Security

Security is a major concern in the ZigBee architecture. Although ZigBee uses the basic security elements in IEEE 802.15.4 (e.g., AES encryption & CCM security modes), the ZE20S increases the security level with:

- 128 bit AES encryption algorithms
- Strong, NIST-approved security
- Defined Key Types (Link, Network)
- Defined Key setup and maintenance

- CCM (Unified/Simpler mode of operation)
- Trust Centers

### 3.5.1 Security Level

In order to use security in the application, a user should set security level using the AT command below. Set 1 defines both Authentication and Encryption at the network layer. Set 0 defines no security. Disabling security in the application is not ZigBee compliant. All nodes in the network should have the same security level setup. The security level is configured using the AT command below.

*AT+SECURITY=n or AT+SE=n, where n is encryption level. (0=disable, 1=enable)*

### 3.5.2 Link Key

The trust center (normally coordinator in network) requests link key before a device is trying to join network. If link key the device has is wrong, joining process will be denied. Hence, all nodes in the network should have the same link key setup before joining the network.

*AT+LINKKEY=xxx...xxx or AT+LK= xxx...xxx, where xxx...xxx is 128-bit hexadecimal trust center link key. Default is FFF...FF.*

### 3.5.3 Network Key

It is the network-wide key used to secure transmissions at the Network Layer. The network key encrypts all transmissions at the Network Layer. The network key only needs to be set up for the coordinator.

*AT+NWKKEY=xxx...xxx or AT+NK=xxx...xxx, where xxx...xxx is 128-bit hexadecimal network key. Default is FFF...FF.*

### 3.5.4 Update Key

A trust center can update the Network Key to help minimize the risk associated with a particular instance of the network key being compromised. Key updates are broadcast by the trust center throughout the network, encrypted using the current network key. Devices that hear the broadcast will not immediately use the key, but simply store it. Later, a key switch is broadcast by the trust center to tell all nodes to start using the new key. At a minimum, the trust center should allow adequate time for the broadcast of the new key to propagate throughout the network before switching.

*AT+UPDATEKEY<CR> or AT+UK<CR>*

## 3.6 Frequency Agility

Frequency Agility refers to the function to shift operating channel to avoid interference. If frequency agility function of coordinator is enabled, the coordinator plays a role in network manager. It monitors communication failures, decides to changes the operating channel and send message to indicate the

channel change. Other nodes in the network move to the designated channel by responding to the message.

The frequency agility needs to be set up only for the coordinator.

*ATS71=n, where n is 0 = disabled, 1 = enabled.*

## 4 Data Transmission

The ZE20S supports three different types of data transmissions: unicast, multicast and broadcast. Unicast is to transmit data to a specific ZigBee device. Multicast is to transmit data to a group of ZigBee devices that are assigned a specific group ID. Broadcast is to transmit data to all ZigBee devices (or specific type of ZigBee nodes if specified) in the network.

ZE20S has such operation modes as command mode and data mode. Data can be transmitted at each operation mode as below:

- Command mode: Because this mode is for entering commands to set and manage a ZE20S, as many data as allowed are transmitted at a time by using AT command.
- Data mode: Because this mode is for transmitting data, it is possible to send data consecutively. “+++” changes the operation mode from the data mode to command mode.

### 4.1 Command Mode

#### 4.1.1 Unicast

Unicast transmissions are sent from a source device to a destination device. The destination device can be any ZigBee device in the ZigBee network. To specify the destination device, the ZigBee address of the destination device should be known.

There are two different ZigBee addresses assigned to each ZigBee device. The 64-bit address is a unique device address assigned during manufacturing. The 64-bit address is also called IEEE address or extended address. The 16-bit address is assigned to the device when it joins a ZigBee network. The ZE20S can send unicast messages based on either 16-bit address or 64-bit address. The AT command for the unicast transmissions is as below:

```
AT+UNICAST=<node_id>,<MSG><CR> or AT+UC=<node_id>,<MSG><CR>
, where <node_id> = 16-bit or 64-bit address, <MSG> = data to transmit
```

The maximum payload of the message is 90 bytes (or 72 bytes under security enabled). If the message length exceeds the maximum payload, the message cannot transmit and the error message will be presented. The AT command to get the maximum payload is as below:

```
AT+MAXPAYLOAD?<CR> or AT+MP?<CR>
```

After unicast transmission timeout, the source device present an error message. Unicast transmission timeout can be set using the AT commands below. Please refer to the **9 S-Registers** for more details.

*ATS32=n, where n is the transmission retries.*

*ATS33=n, where n is the transmission timeout.*

Unicast transmission timeout = (transmission retries + 1) x (transmission timeout)

Multicast and broadcast transmission timeout could be obtained by same way.

#### 4.1.2 Multicast

Multicast transmissions are sent from a source device to destination devices with the specific group ID. The group ID is assigned to the devices using the AT+GROUPID command. The AT command for the multicast transmissions is as below.

*AT+MULTICAST=<group\_id>,<MSG><CR> or AT+MC=<group\_id>,<MSG><CR>  
, where <group\_id> = group ID, <MSG> = data to transmit*

The data transmission range can be set using the AT commands below. Please refer to the **9 S-Registers** for more details.

*ATS36=n, where n is the radius.*

*ATS37=n, where n is the number of hops through nonmembers.*

*Note: ZigBee compliance rules prevents flooding of the network by limiting the network to a maximum of 9 broadcasts over 8 seconds. Attempts to submit additional broadcasts beyond this should result in the transmission error. This is approximately one broadcast per second. It is, however, recommended to broadcast one packet over 2 seconds for safe transmission. Broadcast transmission failure also causes retransmission which is affected by transmission timeout(S33) and transmission retries(S32). Because frequent retransmissions may cause to break the broadcast limitation, it is recommended to set more than 1000 for transmission timeout(S33) and set as small as possible for transmission retries(S32) .*

*Multicast data transmission is implemented on top of the network broadcast mechanism, so it is subject to the same rules.*

#### 4.1.3 Broadcast

Broadcast transmissions are sent from a source device to all devices in the ZigBee network. The AT command for the broadcast transmissions is as below.

*AT+BROADCAST=<MSG><CR> or AT+BC=<MSG><CR>  
, where <MSG> = data to transmit*

The user can also specify the transmission range by changing the S35 register value as below. Please refer to the **9 S-Registers** for more details.

*ATS35=n, where n is the broadcast range.*

$ATS36=n$ , where  $n$  is the radius.

*Note: ZigBee compliance rules prevents flooding of the network by limiting the network to a maximum of 9 broadcasts over 8 seconds. Attempts to submit additional broadcasts beyond this should result in the transmission error. This is approximately one broadcast per second. It is, however, recommended to broadcast one packet over 2 seconds for safe transmission. Broadcast transmission failure also causes retransmission which is affected by transmission timeout(S33) and transmission retries(S32). Because frequent retransmissions may cause to break the broadcast limitation, it is recommended to set more than 1000 for transmission timeout(S33) and set as small as possible for transmission retries(S32).*

*Multicast data transmission is implemented on top of the network broadcast mechanism, so it is subject to the same rules.*

#### 4.1.4 Sending Binary Data

Because some characters like carriage return, line feed and back space collides with AT commands in command mode and back slash('\') is used for control character for binary encoding, they cannot be transmitted as they are. The characters out of range between 0x20(Space) and 0x7E('~') in hexadecimal are not expressed at the AT commands for transmitting data. In order to transmit these characters in command mode, these characters must be encoded in a command line. The examples of special characters encoding are shown in Table 4-1.

Table 4-1 Examples of Special Characters Encoding

HEX	Abbreviation	Glyph	Encoded	Description
00	NULL	-	\00	Null character
0D	CR	-	\0D	Carriage return
0A	LF	-	\0A	Line feed
08	BS	-	\08	Backspace
09	HT	-	\09	Horizontal Tab
7F	DEL	-	\7F	Delete
5C	-	\	\5C	Control character for binary encoding

For example, when sending  $abc<CR>$  with AT+BROADCAST command, the command should be as follows:

`AT+BROADCAST=abc\0D<CR>`

#### 4.1.5 Display Incoming Message

S11 register determines whether incoming message will be shown or not in the command mode. In the data mode, on the other hand, incoming data is always displayed. To change the S11 register, please use the AT command as below:

`ATS11=<value><CR>`

, where <value> = 0 to hide incoming message, 1 to show incoming message.

If user wants to display incoming message in command mode, S11 should be enabled. It is displayed by the form of `+<IEEE address>|<MSG><CR>`.

When displaying incoming messages in command mode, some characters are encoded in the same way with sending binary data as in Table 4-1. For example, when receiving `abc<CR>` from 0001950000000001, the displaying message is as follows:

`+0001950000000001| abc\0D<CR>`

*Note: In PTV1.2 or earlier version, only the characters mentioned at Table 4-1 are encode. In PTV1.3 or later version, back slash('\') and the characters out of range between 0x20(Space) and 0x7E('~') in hexadecimal are encoded.*

## 4.2 Data Mode

If the data is too long to send using the command mode, Data Mode can be used instead. Once the ZE20S enters a Data Mode session, the ZE20S can send data continuously to a specific node or current network until the data mode is escaped. The data is packetized and transmitted at every inter character timeout. This data link to the designated device is maintained until the escape command “+++” is entered. To return to the last data mode after the ZE20S is escaped by “+++”, use the AT command as below.

`ATO<CR>`

### 4.2.1 Unicast Data Mode

Unicast data mode can be used for continuous data transmission to a particular node. Unicast data mode can be entered using either ATD or AT+TRANSMITMODE=1 (or 4). ATD command is the command for entering the unicast data mode. AT+TRANSMITMODE=1 is used to set the data transmission mode to unicast to destination long address and AT+TRANSMITMODE=4 to unicast to sink node.

If ATD command is used, the device will enter the unicast data mode immediately and keep it until escaped using “+++” or reset by ATZ. If the device is reset, it will not enter the unicast data mode but command mode in this case.

On the other hand, if AT+TRANSMITMODE=1 (or 4) is used to enter the unicast data mode, the device enters the unicast data mode again whenever the device is reset. To disable the unicast data mode, escape the data mode first by using “+++” string and use AT+TRANSMITMODE=0 and reset the device to apply the setting permanently.



AT commands used for the unicast data mode are as below.

*AT+DESTLA=<value> or AT+DL=<value>*

, where <value> is 64-bit IEEE address of destination node for unicast data mode.

Set the destination address which is used for ATD command or AT+ TRANSMITMODE=1.

*ATD<CR>*

Set unicast data mode to the preconfigured destination IEEE address without reset.

*ATD<value><CR>*

Set unicast data mode to <value> device and <value> can be either 16-bit node ID or 64-bit IEEE address of remote node.

*AT+TRANSMITMODE=1<CR> or AT+TM=1<CR>*

Set the transmission mode to unicast to a destination IEEE address. The device should be reset to apply the transmission mode.

The 'unicast to sink node data mode' is a kind of unicast data mode where data are not transmitted to the designated destination device but to sink node. A device can be a sink node by setting S-register 61. The sink node multicasts its address to the other devices in the destination group in the network according to the value of S-register 61, which is called advertising. The other devices in the network store the address of the sink node. The devices in the 'unicast to sink node data mode' transmits data to the sink node.

The 'unicast to sink node data mode' is useful for a device to gather data from many devices because every device comes to know the destination device by setting the destination device as sink node instead of describing the destination device to every device. Every device also comes to know the new destination device by changing the sink node in the network.

AT commands used for the 'unicast to sink node data mode' are as below.

*ATS61=<value><CR>*

, where <value> = 0 not sink node, <value> > 0 sink node to advertise its address to the devices in the destination group (AT+DESTGROUPID) every <value> second.

*AT+DESTGROUPID=<value> or AT+DG=<value>*

, where <value> is 16-bit destination group ID to which sink node advertises its address.

Set destination Group ID of the device.

*AT+SINKINFO?<CR> or AT+SI?<CR>*

Get the long and short addresses of sink node. If there is no sink node in the network, the addresses will

be "FFFFFFFFFFFFFFFF" and "FFFF".

**AT+TRANSMITMODE=4<CR> or AT+TM=4<CR>**

Set the transmission mode to unicast to a sink node. The device should be reset to apply the mode.

Example)

```
AT+DESTLA=00019500002FDC40<CR> # Set the destination IEEE address
OK<CR> # Response
ATD<CR> # Enter the unicast mode using destination IEEE address
OK<CR> # Response
Send unicast msg # Put the unicast message
+++ # Leave data mode
OK<CR> # Response
```

```
ATD0000<CR> # Enter the unicast mode using 16-bit node ID
OK<CR> # Response
Send unicast msg # Put the unicast message
+++ # Leave data mode
OK<CR> # Response
```

```
ATD00019500002FDC40<CR> # Enter the unicast mode using 64-bit IEEE address
OK<CR> # Response
Send unicast msg # Put the unicast message
+++ # Leave data mode
OK<CR> # Response
```

```
AT+DESTLA=00019500002FDC40<CR> # Set the destination IEEE address
OK<CR> # Response
AT+TRANSMITMODE=1<CR> # Set transmission mode to destination IEEE address
OK<CR> # Response
ATZ<CR> # Apply to change
OK<CR> # Response
Send unicast msg # Put the unicast message
+++ # Leave data mode
OK<CR> # Response
```

```

AT+TRANSMITMODE=4<CR> # Set transmission mode to sink node in the network
OK<CR>                 # Response
ATZ<CR>                # Apply to change
OK<CR>                 # Response
Send unicast msg       # Put the unicast message
+++                    # Leave data mode
OK<CR>                 # Response

```

#### 4.2.2 Multicast Data Mode

Multicast data mode can be used for continuous data transmission to a particular group of multiple devices. Every ZE20S belongs to a certain group by predetermined group ID when forming or joining the network.

Multicast data mode can be entered using either ATM or AT+TRANSMITMODE=2. If ATM command is used, the device will enter the multicast data mode immediately and keep it until escaped using “+++” or reset by ATZ. If the device is reset, it will not enter the multicast data mode but command mode in this case.

On the other hand, if AT+TRANSMITMODE=2 is used to enter the multicast data mode, the device enters the multicast data mode again whenever the device is reset. To disable the multicast data mode, escape the data mode first by using “+++” string and use AT+TRANSMITMODE=0 and reset the device to apply the setting permanently.

AT commands used for the multicast data mode are as below.

*AT+GROUPLD=<value> or AT+GI=<value>, where <value> is 16-bit group ID for multicast data mode.*

Set Group ID of the device. The device will receive the multicast data sent to this Group ID.

*AT+DESTGROUPLD=<value> or AT+DG=<value>, where <value> is 16-bit destination group ID for multicast data mode.*

Set destination Group ID of the device.

*ATM<CR>*

Set multicast data mode to preconfigured destination group ID without reset.

*ATM<value><CR>*

Set multicast data mode to <value> group ID and <value> can be 16-bit ID.

*AT+TRANSMITMODE=2<CR> or AT+TM=2<CR>*

Set the transmission mode to multicast mode. The device should be reset to apply the mode.

*ATS36=n, where n is the radius.*

*ATS37=n, where n is the number of hops through nonmembers.*

Set data relay and forwarding options. Please refer to the **9 S-Registers** for more details.

*Note: ZigBee compliance rules prevents flooding of the network by limiting the network to a maximum of 9 broadcasts over 8 seconds. Attempts to submit additional broadcasts beyond this should result in the transmission error. This is approximately one broadcast per second. It is, however, recommended to broadcast one packet over 2 seconds for safe transmission. Broadcast transmission failure also causes retransmission which is affected by transmission timeout(S33) and transmission retries(S32). Because frequent retransmissions may cause to break the broadcast limitation, it is recommended to set more than 1000 for transmission timeout(S33) and set as small as possible for transmission retries(S32).*

*Multicast data transmission is implemented on top of the network broadcast mechanism, so it is subject to the same rules.*

Example)

```
AT+DESTGROUPID=0001<CR>    # Set the destination group ID
OK<CR>                      # Response
ATM<CR>                     # Enter the multicast mode using destination group ID
OK<CR>                      # Response
Send multicast msg          # Put the multicast message
+++                          # Leave data mode
OK<CR>                      # Response
```

```
ATM0001<CR>                 # Enter the multicast mode using 16-bit group ID
OK<CR>                      # Response
Send multicast msg          # Put the multicast message
+++                          # Leave data mode
OK<CR>                      # Response
```

```
AT+DESTGROUPID=0001<CR>    # Set the destination group ID
OK<CR>                      # Response
AT+TRANSMITMODE=2<CR>     # Set transmission mode to destination group ID
OK<CR>                      # Response
ATZ<CR>                   # Apply to change
OK<CR>                      # Response
```

```
Send multicast msg      # Put the multicast message
+++                    # Leave data mode
OK<CR>                 # Response
```

### 4.2.3 Broadcast Data Mode

Broadcast data mode can be used for continuous data transmission to all devices in the current network. The destination address or group ID of the remote nodes is not necessary for broadcast data mode. The transmit range is determined by the S-register 35.

Broadcast data mode can be entered using either ATB or AT+TRANSMITMODE=3. If ATB command is used, the device will enter the broadcast data mode immediately and keep it until escaped using “+++” or reset by ATZ. If the device is reset, it will not enter the broadcast data mode but command mode in this case.

On the other hand, if AT+TRANSMITMODE=3 is used to enter the broadcast data mode, the device enters the broadcast data mode again whenever the device is reset. To disable the broadcast data mode, escape the data mode first by using “+++” string and use AT+TRANSMITMODE=0 and reset the device to apply the setting permanently.

AT commands used for the broadcast data mode are as below.

*ATB<CR>*

Set broadcast data mode.

*AT+TRANSMITMODE=3<CR> or AT+TM=3<CR>*

Set the transmission mode to broadcast. It should be reset to apply the mode.

*ATS35=n, where n is the broadcast range.*

*ATS36=n, where n is the radius.*

Set data transmission range. Please refer to the chapter **9 S-Registers** for more details.

*Note: ZigBee compliance rules prevents flooding of the network by limiting the network to a maximum of 9 broadcasts over 8 seconds. Attempts to submit additional broadcasts beyond this should result in the transmission error. This is approximately one broadcast per second. It is, however, recommended to broadcast one packet over 2 seconds for safe transmission. Broadcast transmission failure also causes retransmission which is affected by transmission timeout(S33) and transmission retries(S32). Because frequent retransmissions may cause to break the broadcast limitation, it is recommended to set more than 1000 for transmission timeout(S33) and set as small as possible for transmission retries(S32).*

*Multicast data transmission is implemented on top of the network broadcast mechanism, so it is subject to*

*the same rules.*

**Example)**

```
ATS35=2<CR>      # Set broadcast range to all nodes in the network
OK<CR>           # Response
ATB<CR>          # Enter the broadcast mode
OK<CR>           # Response
Send broadcast msg # Put the broadcast message
+++             # Leave data mode
OK<CR>           # Response
```

```
AT+TRANSMITMODE=3<CR> # Set transmission mode to current network
OK<CR>                 # Response
ATZ<CR>                # Apply to change
OK<CR>                 # Response
Send broadcast msg    # Put the broadcast message
+++                   # Leave data mode
OK<CR>                 # Response
```

## 5 Digital and Analog I/O

### 5.1 GPIO (General Purpose Inputs and Outputs) Configuration

The ZE20S module has total 18 I/O pins. Among these pins, I/O pin 2 is assigned to factory reset only and the user can use the rest 17 pins for general purpose inputs and outputs. The I/O pin assignments are shown in Table 5-1. As shown in Table 5-1, some pins provide special functions built into the firmware. Table 5-2 describes the special functions tied to the specific pins.

Table 5-1 Default I/O Pin Assignments

Pin Number	GPIO Number	Special Functions	AI Enable
2	-	Factory reset / Bootloader ( <b>SW_0</b> )	X
3	0	Permit joining / Wake-up ( <b>SW_1</b> )	X
4	1	UART_DTR	X
5	2	UART_DSR	X
6	3	UART_CTS	X
7	4	UART_RTS	X
8	5		X
9	6		X
10	7		X
11	8		X
32	9		O (AI_0)
31	10		O (AI_1)
30	11		O (AI_2)
29	12		O (AI_3)
28	13		O (AI_4)
27	14		O (AI_5)
24	15	Power LED ( <b>LED_0</b> )	X
23	16	Status LED ( <b>LED_1</b> )	X

The AT command below can be used to change the GPIO settings.

**AT+GPIO=<values><CR> or AT+GPIO<number>=<value><CR>**

, where <values> is a number between 0~5 as explained below:

- 0 Disabled (unmonitored digital input)
- 1 Digital input, monitored
- 2 Digital output, default low
- 3 Digital output, default high
- 4 Analog input, single ended (only valid for GPIO9~14)
- 5 Reserved for pin-specific alternate functionalities (See Table 5-2)

Table 5-2 Special GPIO Pins

Function	GPIO#	Type	Description
Factory_reset / Bootloader	-	DI	This input is dedicated for the factory reset button. If user wants to restore the ZE20S device settings to factory default, this input (falling edge, i.e. High to Low change) needs to be pressed for more than two seconds. It will be applied after the input released again. If this input is pressed while the ZE20S starts, the local node enters bootloader menu and it is possible to upload the firmware. Factory reset button is not available when the ZE20S device is sleeping.
Permit_joining / Wake-up	0	DI	This input (falling edge, i.e. High to Low change) is used to permit joining or interrupt sleeping. This function is activated when GPIO0 is set to 5. The functions depend on the node type of the ZE20S. If the node is set to coordinator or router, this input works to permit other nodes joining for Permit joining timeout(S-register 22 value). If the node is set to sleepy end-device, it is used for wake-up signal when the node is sleeping.
UART_CTS	1	DI	This input is used for UART CTS if GPIO1 is set to 5. It should be enabled when CTS flow control is used.
UART_RTS	2	DO	This output is used for UART RTS if GPIO2 is set to 5. It should be enabled when RTS flow control is used.
UART_DTR	3	DO	This output is used for UART DTR if GPIO3 is set to 5.
UATR_DSR	4	DI	This input is used for UART DSR if GPIO4 is set to 5.
Power LED	15	DO	If GPIO15 is set to 5, this output turns ON (High) when power is supplied. If the node is set to an end-device, it will blink periodically. Please refer to <b>9 S-Registers</b> for S14 regarding the management of the LED status.
Status LED	16	DO	If GPIO16 is set to 5, this output turns ON (High) when the device joins a network, blinks when joining is permitted, and turns OFF (Low) when leaves the network. Please refer to <b>9 S-Registers</b> for S14 regarding the management of the LED status.

## 5.2 I/O Sampling

The I/O status can be monitored and controlled using the AT commands. The I/O status of remote device can be monitored and controlled using remote AT commands, too. The ZE20S can also be configured to sample the I/O status and send to a remote device periodically.

### 5.2.1 Queried Sampling

The I/O status can be monitored and controlled using the AT commands either locally or remotely. To read



the digital I/O line values, the AT+DIO command can be used as below. Return value is a combination of 0 (Low) and 1 (High) if the pins are configured as digital I/O lines. If the pins are configured as analog inputs, the corresponding return values are shown as \*.

*AT+DIO?<CR> or AT+DIO<number>?<CR>*

*, where <number> is the specific IO number between ranges 0 ~ 16 to read*

AT+DIO command can also be used to set the digital output lines.

*AT+DIO=<value><CR> or AT+DIO<number>=<value><CR>*

*, where <number> is the specific IO number between ranges 0 ~ 16 to read, and the <values> is a combination of 0 or 1, 0 = Low, 1 = High*

The analog input values can be read using the AT+AI command. Return value is a combination of 16-bit hexadecimal integer between 0~2EE0(0~1200.0mV) which unit value corresponds to 0.1mv. To convert the hexadecimal value to the actual voltage, please use the formula below. If the pins are configured as digital I/Os, the corresponding return values are shown as \*.

*AT+AI?<CR> or AT+AI<number>?<CR>*

*, where <number> is the specific IO number between ranges 0 ~ 5 to read*

*If the Value is between 0 ~ 7FFF, Voltage (mV) = Value \* 0.1*

*If the Value is between 8000 ~ FFFF, Voltage (mV) = (Value – 65536) \* 0.1*

#### Example)

```
AT+DIO?<CR>
10001000111**0000      ← DIO 0, 4, 8, 9, 10 are ON. GPIO11, 12 are configured
as analog inputs
OK
AT+DIO0=0<CR>
OK
AT+DIO?<CR>
00001000111**0000      ← DIO 4, 8, 9, 10 are ON. GPIO11, 12 are configured as
analog inputs
OK
AT+AI?<CR>
****,****,192A,13E8,****,****      ← AI 2, 3 are used. (GPIO11, 12) The others
are configured as DIO.
OK
```

To get/set the I/O values of the remote devices, remote AT commands can be used as below.

*AT+REMOTE=<node ID or IEEE address of a remote node>,<AT command><CR>*

Example)

```
AT+REMOTE=00019500000F3BA1,AT+DIO?<CR>
10001000111**0000
OK
```

### 5.2.2 Periodic Sampling

The ZE20S can be configured to send its I/O status to a remote device at a periodic rate. To configure this way, please use the AT commands below:

*AT+DESTLA=<IEEE address><CR> or AT+DL=<IEEE address><CR>*

*, where <IEEE address> is the long address of a remote node to send sampled GPIO values of local node.*

*ATS42=<value><CR>*

*, where <value> is the GPIO sampling period in seconds. If set to 0, GPIO monitoring is disabled.*

*ATS43=<value><CR>*

*, where <value> is the GPIO monitoring node. If set to 0, the monitoring node is selected by AT+DESTLA. If set to 1, the sink node is set as the monitoring node.*

A device can be a sink node by setting S-register 61. The sink node multicasts its address to the other devices in the destination group in the network according to the value of S-register 61, which is called advertising.

*ATZ<CR>*

Reset the device to apply the changes

The ZE20S can be configured to display periodic sampling data coming from the other nodes. To enable this feature, please use the AT command below:

*ATS11=<value><CR>*

*, where <value> determines whether incoming message will be presented or not. If a user wants to display incoming message in command mode, S11 should be enabled.*

If this feature is enabled, incoming message will display in the form of:

++<IEEE address>|<GPIO value><CR>.

### 5.2.3 Change Detection Sampling

The ZE20S module can take an I/O sample and transmit it to a remote device immediately whenever a monitored digital I/O pin changes state. It is possible to configure it with periodic sampling simultaneously. To configure this way, please use the AT commands below:

**AT+DESTLA=<IEEE address><CR>**

, where <IEEE address> is the long address of a remote node to send sampled GPIO values of local node.

**ATS43=<value><CR>**

, where <value> is the GPIO monitoring node. If set to 0, the monitoring node is selected by AT+DESTLA. If set to 1, the sink node is set as the monitoring node.

**ATS44=<value><CR>**

Set GPIO change detection sampling mode. If <value> is set to 0, GPIO sampling is disabled.

**ATZ<CR>**

Reset the device to apply the changes

*Note: This function applies to only digital I/O.*

### 5.2.4 GPIO Remote Control

The ZE20S module supports that a local node can change the digital output status by switching digital input pins of a remote node. To use this function, it should be possible for the local node to monitor the GPIO status of the remote node (GPIO monitoring period, S42 > 0) or to detect the GPIO change of the remote node (GPIO change detection sampling mode, S44 = 1). To configure this way, please use the AT commands below:

**AT+SOURCELA=<IEEE address><CR> or AT+SL=<IEEE address><CR>**

, where <IEEE address> is the long address of a specific source node for changing the status of digital output pin. If this address is set to "FFFFFFFFFFFFFFFF", a local node allows that any node can control the GPIO status.

**ATS45=<value><CR>**

Set GPIO remote control mode. If <value> is set to 0, GPIO control is disabled.

*Note: This function applies to only digital I/O.*

## 6 Working with Development Kit

The ZE20S development kit provides a quick and easy way to be familiar with the ZE20S and test its functionalities before you build your own PCB board to carry the ZE20S. It is always recommended to start with the ZE20S development kit before your own design.

### 6.1 Development Kit Contents

The development kit consists of ZE20S modules and development boards to carry them. The development board provides RS232 and USB interface to interface with computers and/or your target devices. It provides terminals for digital inputs/outputs and analog inputs, too. It also provides on/off switches and LEDs to simulate and verify digital inputs/outputs. In addition, it has temperature and light sensor so you can test more practical applications. Below is the list of the items included in the package.

- ProBee ZE20S ZigBee OEM Module w/ Chip Antenna (ProBee-ZE20SDC) (1)
- ProBee ZE20S ZigBee OEM Module w/ U.FL Connector (ProBee-ZE20SDU) (1)
- ProBee ZE20S ZigBee OEM Module w/ RPSMA Connector (ProBee-ZE20SDS) (1)
- 3 dBi Dipole Antenna, RP-SMA Plug, Right-hand Thread (2)
- 12cm U.FL to RPSMA Cable, Right-Hand Thread (1)
- Development Boards (3)
- DC Power Adapters (3)
- RS232 Serial Cable (3)
- USB Cable (3)

### 6.2 Development Board Features

The development board is designed to provide convenient access to the ZE20S interface pins. The development board provides external interfaces as below. Also Figure 6-1 shows the layout of those interfaces of the development board.

- RS232 Interface
- USB Interface
- 3 Pre-defined Digital Inputs: Hardware Reset, Factory Default Reset, Permit Joining
- 8 User Configurable Digital Input Buttons
- 8 Digital Outputs with LEDs (Active High)
- 4 Analog Inputs
- Temperature Sensor
- Light Sensor

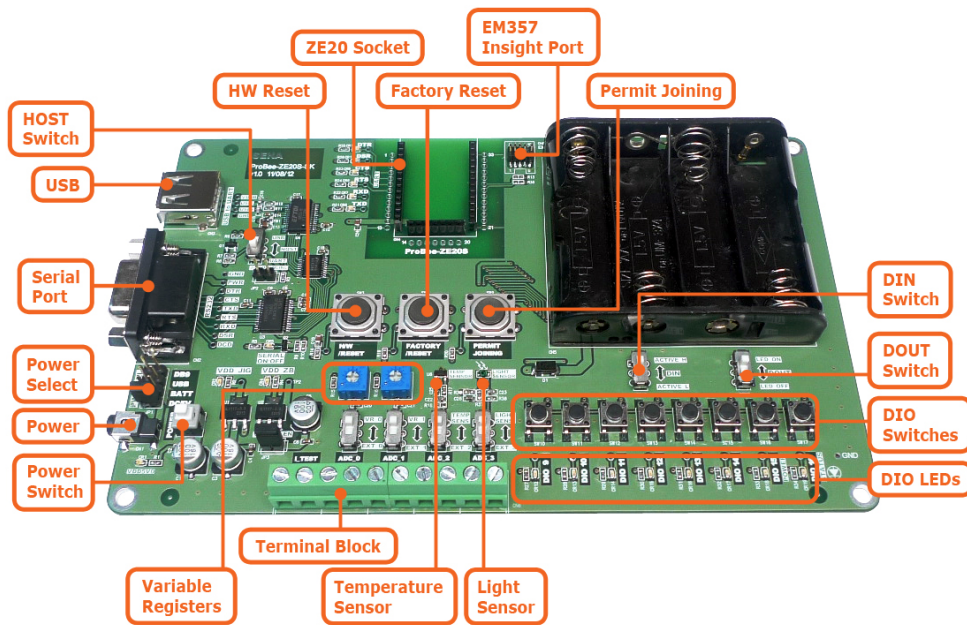

Figure 6-1 Development Board Layout

### 6.3 Development Board Hardware Descriptions

#### 6.3.1 Power

There are four ways to supply power to the development board:

- 5V Power Adapter
- USB Port
- Batteries (AA 1.5V x 4)
- RS232 Port (5V through 9<sup>th</sup> Pin)

The PWR\_SEL(JP1) jumper MUST be configured properly according to the way to supply power. Table 6-1 shows jumper configuration.

Table 6-1 Jumpers Configuration

		5V Power Adapter	Batteries	USB Port	RS232 Port
<b>PWR_SEL</b>	<b>DB9</b>				
	<b>USB</b>				
	<b>BATT</b>				
	<b>DC5V</b>				

#### 6.3.2 RS232 Port

The development board has an RS232 interface for UART communication. The UART\_TXD, UART\_RXD, UART\_DSR (GPIO\_1), UART\_DTR (GPIO\_2), UART\_CTS (GPIO\_3) and UART\_RTS (GPIO\_4) pins of

the ZE20S are connected with the RS232 port. To enable the RS232 port, the HOST (SW2) switch should be set to UART.

In addition to the data communication via RS232 port, the RS232 port is capable of supplying power to the development board. In order to use this feature, supply 5V power via the 9<sup>th</sup> pin of the DB9 socket.

### 6.3.3 USB Port

The development board also has a USB interface for UART communication. To use the USB port, the HOST (SW2) switch should be set to USB and the software driver should be installed on the host computer. The installation CD contains the software.

### 6.3.4 ZE20S GPIO Interface

The development board's external GPIO interfaces as well as functional buttons such as factory default reset switches are internally routed to the ZE20S GPIO pins. Table 6-2 summarizes the development board's interfaces and their corresponding GPIO pin numbers of the ZE20S.

*Table 6-2 Development Board GPIO Interface Allocation*

<b>ZE20S Pin Number</b>	<b>Name</b>	<b>Description</b>
2	Factory Reset	Factory Default Reset Switch (SW8)
3	GPIO_0	Permit Joining Switch (SW9)
4	GPIO_1	UART DTR Output
5	GPIO_2	UART DSR Input
6	GPIO_3	UART CTS Input
7	GPIO_4	UART RTS Output
22	H/W Reset	Hardware Reset Switch
23	GPIO_16	Digital Output with LED(CR19) Display (Active High) Digital Input with Button Switch (SW17, Active Low or Active High)
24	GPIO_15	Digital Output with LED(CR18) Display (Active High) Digital Input with Button Switch (SW16, Active Low or Active High)
25	UART_RXD	UART Data Input
26	UART_TXD	UART Data Output
27	GPIO_14 *	Digital Output with LED(CR17) Display (Active High) Digital Input with Button Switch (SW15, Active Low or Active High)
28	GPIO_13	Digital Output with LED(CR16) Display (Active High) Digital Input with Button Switch (SW14, Active Low or Active High)
29	GPIO_12	Digital Output with LED(CR15) Display (Active High) Digital Input with Button Switch (SW13, Active Low or Active High) Analog Input with Light Sensor (U7)

30	GPIO_11	Digital Output with LED(CR14) Display (Active High) Digital Input with Button Switch (SW12, Active Low or Active High) Analog Input with Temperature Sensor (U6)
31	GPIO_10	Digital Output with LED(CR13) Display (Active High) Digital Input with Button Switch (SW11, Active Low or Active High) Analog Input with Variable Register (VR2)
32	GPIO_9	Digital Output with LED(CR12) Display (Active High) Digital Input with Button Switch (SW10, Active Low or Active High) Analog Input with Variable Register (VR1)

\* NOTE: GPIO\_14 is driven low at pin reset or power-on-reset, the module will boot up in bootloader.

### 6.3.5 LEDs (CR12-19)

The development board has 8 LEDs for digital output. To enable the LEDs, the GPIO\_OUT (SW20) switch should be set to LED\_ON. The LEDs are turned on when the related GPIO pins of the ZE20S are high.

*Note: The ADC\_0~3 switches (SW4~7) should be placed to EXT\_0~3.*

### 6.3.6 Button Switches (SW10-17)

The development board has 8 button switches for digital input. The switches can be configured as active high or active low with the GPIO\_IN (SW19) switch.

*Note: The ADC\_0~3 switches (SW4~7) should be placed to EXT\_0~3.*

*Note: The LED On/Off switch (SW20) should be placed to LED\_OFF.*

*Note: If the GPIO\_IN (SW19) is set to Active High, GPIO pull up/down option should be set to Pull-Down (ATS41=0). If the GPIO\_IN (SW19) is set to Active Low, GPIO pull up/down option should be set to Pull-Up. (ATS41=1)*

### 6.3.7 Variable Resistors (VR1, VR2)

There are two variable resistors for analog inputs on the development board. The analog inputs can be read with the GPIO\_9 and GPIO\_10. To enable the variable resistors, the ADC\_0 and ADC\_1 switches should be placed to VR\_0 and VR\_1.

*Note: The LED On/Off switch (SW20) should be placed to LED\_OFF.*

### 6.3.8 Temperature Sensor

The GPIO\_11 of the ZE20S is routed to the temperature sensor. The relationship between temperature and analog input is as follows:

$$\text{Temperature}(\text{°C}) = \{ \text{Volt}(\text{mV}) - 600(\text{mV}) \} * 0.1(\text{°C/mV})$$

*Note: The LED On/Off switch (SW20) should be placed to LED\_OFF.*

### 6.3.9 Light Sensor

The GPIO\_12 of the ZE20S is routed to the light sensor. Approximately, the relationship between illumination and analog input is as follows:

$$\text{Illumination(Lux)} = \text{Volt(mV)} * 0.25(\text{Lux/mV})$$

*Note: The LED On/Off switch (SW20) should be placed to LED\_OFF.*

### 6.3.10 Terminal Block

The development board has a terminal block for external analog inputs. Figure 6-2 shows the layout of the terminal block. To use external analog inputs instead of the variable resistors, temperature sensor or light sensor, the ADC\_0 (SW4), ADC\_1 (SW5), ADC\_2 (SW6) or ADC\_3 (SW7) should be placed on EXT\_0, EXT\_1, EXT\_2, or EXT\_3.

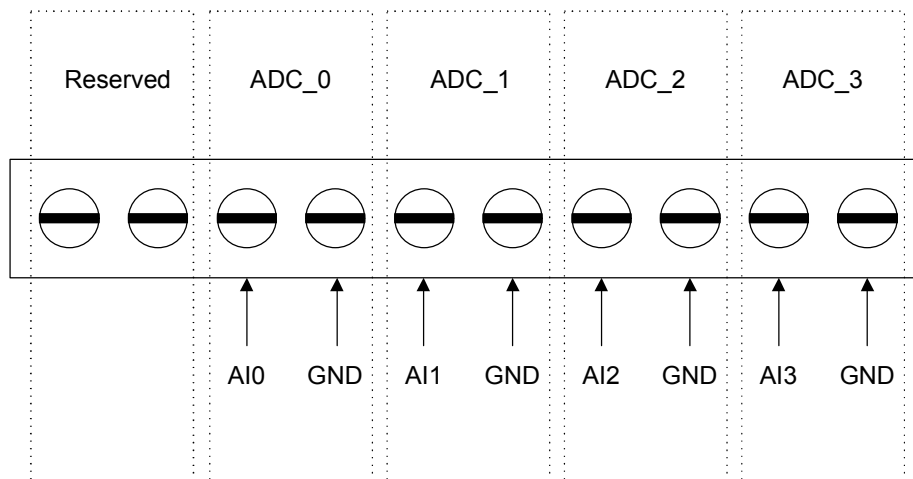

Figure 6-2 Terminal Block for External Analog Inputs

*Note: The LED On/Off switch (SW20) should be placed to LED\_OFF.*

## 6.4 Configuration Example #1: 1 Coordinator, 1 Router and 1 End-Device

Here is the example configuration to help to start with the ZE20S and the development kit. The goal of this example is to provide hardware configuration and AT commands for the scenario as below:

- One ZE20S module acts as a coordinator and it is connected to a host computer via USB cable.
- One ZE20S module acts as a router and it sends temperature sensor, light sensor and digital inputs to the coordinator every second.
- One ZE20S module acts as a sleepy end-device and it sends temperature sensor, light sensor and digital inputs to the coordinator every second.



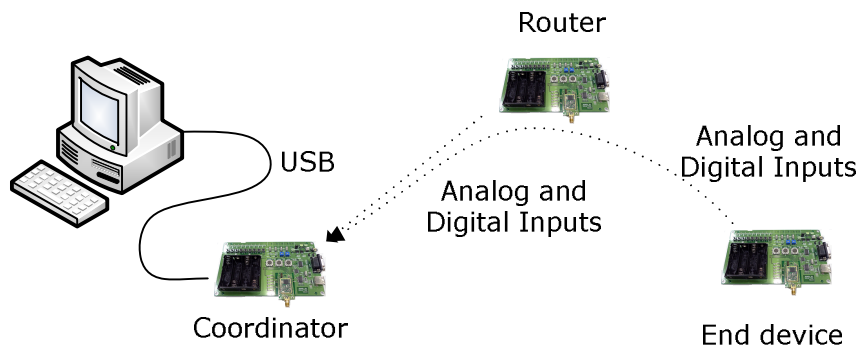

Figure 6-3 Example #1: 1 Coordinator, 1 Router and 1 End-Device

#### 6.4.1 Coordinator Configuration

Hardware configuration for the coordinator is as follows:

- Set the HOST switch to USB
- Close the USB\_PWR jumper and open the RS\_PWR and BATT\_PWR jumpers.
- Connect a USB cable between a host computer and the coordinator

The AT commands for the coordinator are as follows:

```
AT+NODETYPE=1
OK
AT+PANID=7772
OK
ATS11=1
OK
AT+LONGADDR
0001950000000001
OK
ATZ
OK
```

#### 6.4.2 Router Configuration

Hardware configuration for the coordinator is as follows:

- Set the ADC\_2 and ADC\_3 switch to TEMP\_SENS and LIGHT\_SENS

The AT commands for the router are as follows:

```
AT+NODETYPE=2
OK
```

```

AT+PANID=7772
OK
ATS42=1
OK
AT+DESTLA=0001950000000001
OK
AT+GPIO=11111111111441111
OK
ATZ
OK

```

### 6.4.3 End-device Configuration

Hardware configuration for the end-device is as follows:

- Set the ADC\_2 and ADC\_3 switch to TEMP\_SENS and LIGHT\_SENS

The AT commands for coordinator configuration is as follows:

```

AT+NODETYPE=4
OK
AT+PANID=7772
OK
ATS42=1
OK
AT+DESTLA=0001950000000001
OK
AT+GPIO=11111111111441111
OK
ATZ
OK

```

### 6.4.4 Monitoring the Sensors

Once the configurations are done and the system is running, the terminal (computer) connected to the coordinator will print out the incoming data as follows:

```

++0001950000000002|1000000000**0000|****,****,233E,006A,****,****
++0001950000000003|1000000000**0000|****,****,2254,0B23,****,****
++0001950000000002|1000000000**0000|****,****,2235,004E,****,****
++0001950000000003|1000000000**0000|****,****,226C,0B8B,****,****

```

## 6.5 Configuration Example #2: 1 Coordinator and 2 End-Devices

Here is another example assuming different system configurations. This example can be described as follows:

- One ZE20S module acts as a coordinator and it is connected to a host computer via serial cable.
- Two ZE20S modules act as end-devices.
- Turn on/off the LEDs of the end-devices remotely through the coordinator

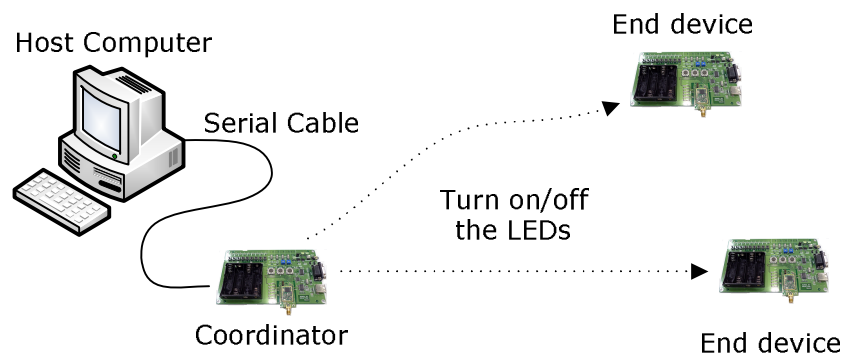

Figure 6-4 Example #2: 1 Coordinator and 2 End-Devices

### 6.5.1 Coordinator Configuration

Hardware configuration for the coordinator is as follows:

- Set the HOST switch to UART
- Connect a serial cable between a host computer and the coordinator

The AT commands for coordinator configuration is as follows:

```
AT+NODETYPE=1
OK
AT+PANID=7772
OK
ATZ
OK
```

### 6.5.2 End-devices Configuration

Hardware configuration for the coordinator is as follows:

- Set the GPIO\_OUT switch to LED\_ON

The AT commands for the end-devices are as follows:

```
AT+NODETYPE=4
OK
```

```

AT+PANID=7772
OK
AT+GPIO=33333333333333333333
OK
AT+LONGADDR
0001950000000003
OK
ATZ
OK

```

### 6.5.3 Turning on/off the LEDs

The AT commands to control the LEDs are as follows:

```

AT+REMOTE=0001950000000003,AT+DIO=000000000000000000
OK
AT+REMOTE=0001950000000003,AT+DIO=111111111111111111
OK

```

## 6.6 Configuration Example #3: Light Sensor and Temperature Sensor

Here is an example sampling light sensor data and temperature sensor data. This example can be described as follows:

- One ZE20S module acts as a coordinator and it is connected to a host computer via serial cable.
- One ZE20S modules act as a router.
- Sampling light sensor data and temperature sensor data in many ways

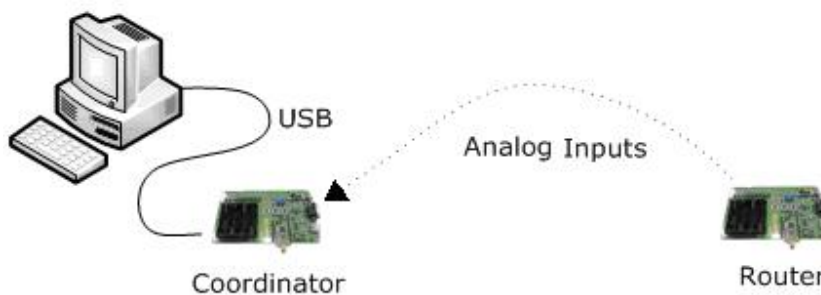

Figure 6-5 Example #3: Light Sensor and Temperature Sensor

### 6.6.1 Coordinator Configuration

Hardware configuration for the coordinator is as follows:

- Set the HOST switch to USB

- Close the USB\_PWR jumper and open the RS\_PWR and BATT\_PWR jumpers.
- Connect a USB cable between a host computer and the coordinator

The AT commands for the coordinator are as follows:

```
AT+NODETYPE=1          # Set node type as Coordinator
OK                      # Response
AT+PANID=7772          # Set 16-bit PAN ID (7772)
OK                      # Response
```

### 6.6.2 Router Configuration

Hardware configuration for the coordinator is as follows:

- Set the ADC\_2 and ADC\_3 switch to TEMP\_SENS and LIGHT\_SENS

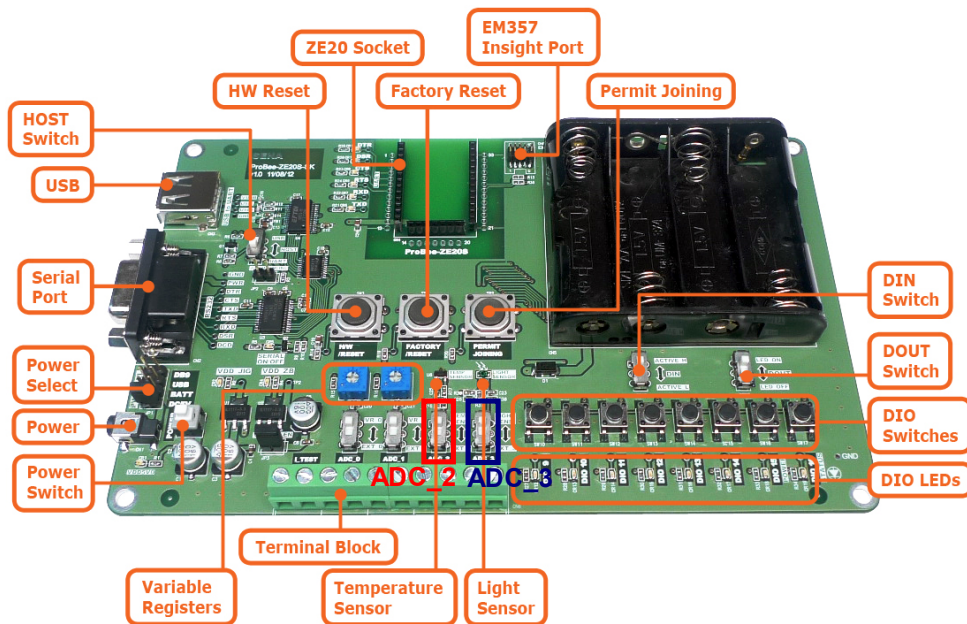

Figure 6-6 Hardware Configuration

The AT commands for the router are as follows:

```
AT+NODETYPE=2          # set node type as Router
OK                      # Response
AT+PANID=7772          # Set same 16-bit PAN ID (7772) as Coordinator
OK                      # Response
AT+GPIO=55555000000440055 # Set ADC_2 and ADC_3 as Analog Input
                        # OR
```

```

#AT+GPIO11=4 (Set ADC_2 as Analog Input)
#AT+GPIO12=4 (Set ADC_3 as Analog Input)
OK # Response

```

### 6.6.3 Applying

#### 6.6.3.1 Applying and Confirm of Coordinator

The AT commands for Applying and Confirm of Coordinator:

```

ATZ # Apply Coordinator Configuration And
# Construct Network
OK # Response
AT+LONGADDR? # Confirm Long Address of Coordinator
0001950000001481 # Long Address of Coordinator
OK # Response
AT+OPCH? # Confirm Network Channel
20 # Network Channel
OK # Response
AT+OPPANID? # Confirm Network PAN ID
7772 # Network PAN ID
OK # Response
AT+SHORTADDR? # Confirm Network Short Address of Coordinator
0000 # Network Short Address
OK # Response

```

#### 6.6.3.2 Applying and Confirm of Router

The AT commands for Applying and Confirm of Coordinator:

```

ATZ # Apply Router Configuration And Construct Network
OK # Response
AT+LONGADDR? # Confirm Long Address of Router
0001950000000212 # Long Address of Router
OK # Response
AT+OPCH? # Confirm Network Channel
20 # Network Channel
OK # Response
AT+OPPANID? # Confirm Network PAN ID
7772 # Network PAN ID
OK # Response

```

```

AT+SHORTADDR?          # Confirm Network Short Address of Router
9AD6                   # Network Short Address
OK                      # Response

```

## 6.6.4 Queried Sampling

### 6.6.4.1 Getting Analog Data at Router

The AT commands for Getting Analog Data at Router:

```

AT+AI?                # Get all the analog data
****,****,2179,0DFE,****,**** # Analog Data
# NA,NA, Termerature, Illumination, NA, NA
# (Variable Register 0, 1 are set as they are not available)
# Refer 6.6.7 Data Conversion for Conversion of Analog Data
# to Temperature and Illumination
OK                      # Response
AT+AI2?               # Get analog data for temperature
2182                   # Analog data for temperature(Refer to 6.6.7 Data Conversion)
OK                      # Response
AT+AI3?               # Get analog data for illumination
0BF9                   # Analog data for illumination(Refer to 6.6.7)
OK                      # Response

```

### 6.6.4.2 Getting Analog Data at Coordinator

The AT commands for Getting Analog Data at Coordinator:

```

AT+REMOTE=000195000000212,AT+AI?
# Get all the analog data of Router from remote Coordinator
****,****,2194,0DF3,****,****
# Analog data of Router
# NA,NA, Temperature, Illumination, NA, NA
# (Variable Register 0, 1 are set as they are not available)
# Refer 6.6.7 Data Conversion for Conversion of Analog Data
# to Temperature and Illumination
OK                      # Response
AT+REMOTE=9AD6,AT+AI?
# Get all the analog data of Router from remote coordinator
****,****,218F,0D9A,****,****
# Analog data of Router

```

```

OK                                     # Response
AT+REMOTE=0001950000000212,AT+AI2?
                                     # Get router's analog data for temperature from remote coordinator
218F                                  # Router's analog data for temperature (Refer to 6.6.7 Data
                                     # Conversion)
OK                                     # Response
AT+REMOTE=9AD6,AT+AI3?
                                     # Get router's analog data for illumination from remote coordinator
0D8D                                  # Router's analog data for illumination (Refer to 6.6.7 Data
                                     # Conversion)
OK                                     # Response

```

## 6.6.5 Periodic Sampling – Destination Node

### 6.6.5.1 Coordinator Configuration

The AT commands for Coordinator Configuration:

```

ATS11=1                               # Set coordinator to receive incoming data
OK                                     # Response
ATZ                                    # Apply configuration
OK                                     # Response

```

### 6.6.5.2 Router Configuration

The AT commands for Router Configuration:

```

AT+DESTLA=0001950000001481
                                     # Set coordinator to the destination device to send
                                     # analog data such as temperature, illumination
OK
ATS42=1                               # Period to send analog data to destination (unit : second)
OK                                     # Response
ATS43=0                               # Set destination to AT+DESTLA
                                     # ATS43=1 sets destination to sink node
ATZ                                    # Apply configuration
OK                                     # Response

```

### 6.6.5.3 Temperature / Illumination Data at Coordinator

The AT commands for Sampling Temperature / Illumination at Coordinator:

```

++0001950000000212|1100000000**0000|****,****,21D6,0C72,****,****

```



```

++0001950000000212|1100000000**0000|****,****,21D0,0B87,****,****
++0001950000000212|1100000000**0000|****,****,21CB,0324,****,****
# Data changes after covering sensors with fingers
++0001950000000212|1100000000**0000|****,****,229B,0084,****,****
++0001950000000212|1100000000**0000|****,****,22A7,009E,****,****
++0001950000000212|1110000000**0000|****,****,22A9,002D,****,****

```

- Data displayed at coordinator every second
- Data format : ++<IEEE address>|<GPIO value>|<Analog Input Data>
- Refer to 6.6.7 Data Conversion about how to convert to analog data to temperature and illumination

## 6.6.6 Periodic Sampling – Sink Node

### 6.6.6.1 Coordinator Configuration

The AT commands for Coordinator Configuration:

```

ATS11=1          # Set coordinator to receive incoming data
OK              # Response
ATS61=10        # Set coordinator to sink node which multicasts its
                # address to the devices in AT+DESTGROUPID every 10 sec.
OK              # Response
ATZ             # Apply configuration
OK              # Response

```

### 6.6.6.2 Router Configuration

The AT commands for Router Configuration:

```

AT+DESTLA=0000000000000000
# Reset destination to send analog data (Destination address does not
# affect on sending analog data to sink node but reset destination to
# confirm that analog data are sent to sink node)
OK              # Response
ATS42=1        # Period to send analog data to sink node (unit : second)
OK              # Response
ATS43=1        # Set destination to sink node
                # ATS43=0 sets destination to AT+DESTLA
ATZ             # Apply configuration
OK              # Response

```

### 6.6.6.3 Temperature / Illumination Data at Coordinator

The AT commands for Sampling Temperature / Illumination at Coordinator:

```
++0001950000000212|1110000000**0000|****,****,217F,0CD8,****,****
++0001950000000212|1110000000**0000|****,****,217E,0A2D,****,****
++0001950000000212|1110000000**0000|****,****,217F,0D19,****,****
# Data changes after covering sensors with fingers
++0001950000000212|1110000000**0000|****,****,2240,007A,****,****
++0001950000000212|1110000000**0000|****,****,22E8,0078,****,****
++0001950000000212|1110000000**0000|****,****,2301,00A6,****,****
```

- Refer to 6.6.7 Data Conversion about how to convert to analog data to temperature and illumination

## 6.6.7 Data Conversion

### 6.6.7.1 Analog Data Format

Analog data from temperature sensor and illumination sensor are a combination of 16-bit hexadecimal integer between 0~2EE0(0~1200.0mV) which unit value corresponds to 0.1 mv.

### 6.6.7.2 Conversion of Analog Data

- Conversion of Analog Data to Actual Voltage  
If the Value is between 0 ~ 7FFF, Voltage (mV) = Value \* 0.1  
If the Value is between 8000 ~ FFFF, Voltage (mV) = (Value – 65536) \* 0.1
- Conversion of Actual Voltage to Temperature  
Temperature(°C) = { Volt(mV) - 600(mV) } \* 0.1(°C/mV)
- Conversion of Actual Voltage to Illumination  
Illumination(Lux) = Volt(mV) \* 0.25(Lux/mV)

### 6.6.7.3 Examples

```
++0001950000000212|1110000000**0000|****,****,217F,0CD8,****,****
++0001950000000212|1110000000**0000|****,****,217E,0A2D,****,****
++0001950000000212|1110000000**0000|****,****,217F,0D19,****,****
# Conversion 1
# Data changes after covering sensors with fingers
++0001950000000212|1110000000**0000|****,****,2240,007A,****,****
# Conversion 2
++0001950000000212|1110000000**0000|****,****,22E8,0078,****,****
++0001950000000212|1110000000**0000|****,****,2301,00A6,****,****
```

Examples show conversion of data at 6.6.6.3 Temperature / Illumination Data at Coordinator.

# Conversion 1 ( ++0001950000000212|11100000000\*\*0000|\*\*\*\*,\*\*\*\*,217F,0D19,\*\*\*\*,\*\*\*\*)

[Temperature Conversion]

Analog Data from Temperature Sensor: 217F (in hexadecimal)

Analog Data from Temperature Sensor: 8575 (in decimal)

Actual Voltage: Volt(mV) =  $8575 * 0.1 = 857.5$ (mV)

Temperature: Temperature(°C) =  $(857.5 - 600) * 0.1 = 25.75$ (°C)

[Illumination Conversion]

Analog Data from Illumination Sensor: 0D19 (in hexadecimal)

Analog Data from Illumination Sensor: 3353 (in decimal)

Actual Voltage: Volt(mV) =  $3353 * 0.1 = 335.3$ (mV)

Illumination: Illumination(Lux) =  $335.3 * 0.25 = 85.83$ (Lux)

# Conversion 2 ( ++0001950000000212|11100000000\*\*0000|\*\*\*\*,\*\*\*\*,2240,007A,\*\*\*\*,\*\*\*\*)

[Temperature Conversion]

Analog Data from Temperature Sensor: 2240 (in hexadecimal)

Analog Data from Temperature Sensor: 8768 (in decimal)

Actual Voltage: Volt(mV) =  $8768 * 0.1 = 876.8$  (mV)

Temperature: Temperature(°C) =  $(876.8 - 600) * 0.1 = 27.68$ (°C)

[Illumination Conversion]

Analog Data from Illumination Sensor: 007A (in hexadecimal)

Analog Data from Illumination Sensor: 122 (in decimal)

Actual Voltage: Volt(mV) =  $122 * 0.1 = 12.2$ (mV)

Illumination: Illumination(Lux) =  $12.2 * 0.25 = 3.05$ (Lux)

## 7 AT Command Reference

### 7.1 Command Line Format

Each command line is composed of a prefix, body and terminator. Only “AT” can be used for the prefix. The body is a string of characters. The terminator is <CR> or <NL>. A command can be one of the followings:

- Read a configuration parameter:  
AT<Command>?<CR>
- Do something:  
AT<Command><CR>
- Write a configuration parameter:  
AT<Command>=<Parameter 1>,<Parameter 2>,<Parameter 3>,...<CR>

Commands denoted with a “+” character are extended AT commands.

S-registers are supported. Multiple commands in the same command line are not supported.

### 7.2 Standard AT Commands

#### 7.2.1 AT

<b>Description</b>	Check the state of the connection between host and ProBee device.
<b>Execute</b>	AT<CR>
<b>Response</b>	OK<CR>

#### 7.2.2 ATB

<b>Description</b>	Enter the broadcast data mode. Every data is packetized at intervals of inter character timeout (S12) and transmit range is determined by broadcast range (S35).
<b>Execute</b>	ATB<CR>
<b>Response</b>	OK<CR>

#### 7.2.3 ATD

<b>Description</b>	Enter the unicast data mode to specific node. If there's no argument after the command, it will connect to the preconfigured destination IEEE address (AT+DESTLA). Every data is packetized at intervals of inter character timeout (S12).		
<b>Execute</b>	ATD<CR>	ATD<nodeID><CR>	ATD<IEEE><CR>
<b>Response</b>	OK<CR> or ERROR<CR>		

**7.2.4 ATE**

Description	Echo(1) or No Echo(0).
Execute	ATE<number><CR>
Response	OK<CR>

**7.2.5 ATM**

Description	Enter the multicast mode. If there's no argument after the command, it will connect to the preconfigured destination group ID(AT+DESTGROUPLD). Every data is packetized at intervals of inter character timeout (S12).	
Execute	ATM<CR>	ATM<groupID><CR>
Response	OK<CR>	

**7.2.6 ATO**

Description	Return to data mode.
Execute	ATO<CR>
Response	

**7.2.7 ATR**

Description	Response(1) or No Response(0).
Execute	ATR<number><CR>
Response	OK<CR>

**7.2.8 ATS**

Description	Get/Set the S-registers.		
Execute	ATS<CR>	ATS<number>?<CR>	ATS<number>=<value><CR>
Response	List of the S-register and description	<value><CR> OK<CR>	OK<CR> or ERROR<CR>

**7.2.9 ATZ**

Description	Reset the node.
Execute	ATZ<CR>
Response	OK<CR>

**7.2.10 AT&F**

Description	Factory reset.
Execute	AT&F<CR>
Response	OK<CR>

**7.2.11 +++**

Description	Interrupt data mode. “+++” must be entered within 500ms.
Execute	+++
Response	OK<CR>

**7.3 Node Specific Information**

**7.3.1 AT+LONGADDR or AT+LA**

Description	Get the 64-bit IEEE address. (EUI address, long address) The IEEE address is a unique device address assigned during manufacturing. This address is unique to each physical device.
Execute	AT+LONGADDR?<CR>
Response	<IEEE address><CR> OK<CR>

**7.3.2 AT+SHORTADDR or AT+SA**

Description	Get the 16-bit Node ID. (network address, short address) The node ID of “0000” is reserved for the coordinator. All other devices receive a randomly generated address from the coordinator or router device that allows the join. This value can change if an address conflict is detected where two devices are found to have the same address or a device leaves the network and later joins.
Execute	AT+SHORTADDR?<CR>
Response	<node ID><CR> OK<CR>

**7.3.3 AT+ADDRDISCOVERY or AT+AD**

Description	Get the corresponding address of a node whose long or short address is known.	
Execute	AT+ADDRDISCOVERY=<IEEE><CR>	AT+ADDRDISCOVERY=<nodeID><CR>
Response	<node ID><CR> OK<CR>	<IEEE address><CR> OK<CR>

**7.3.4 AT+OPCH or AT+OC**

Description	Get the operating channel number used for transmitting and receiving between RF modules. Uses 802.15.4 channel numbers. A value of “0” means the device has not joined a PAN and is not operating on any channel.
Execute	AT+OPCH?<CR>
Response	<value><CR> OK<CR>

**7.3.5 AT+OPPANID or AT+OI**

Description	Get the operating 16-bit PAN ID. If PAN ID is set specific value not 0s, operating PAN ID will equal designated PAN ID. A value of "FFFF" means the device is not joined a network.
Execute	AT+OPPANID?<CR>
Response	<value><CR> OK<CR>

**7.3.6 AT+OPEPID or AT+OE**

Description	Get the operating 64-bit extended PAN ID. A value of "FFFFFFFFFFFFFFFF" means the device is not joined a network.
Execute	AT+OPEPID?<CR>
Response	<value><CR> OK<CR>

**7.3.7 AT+VERSION or AT+VR**

Description	Get firmware version of the module. The firmware version returns a form of "PTvx.x".
Execute	AT+VERSION?<CR>
Response	<value><CR> OK<CR>

**7.3.8 AT+PRODUCTNAME or AT+PN**

Description	Get the product name. It can be used to distinguish among different hardware platforms.
Execute	AT+PRODUCTNAME?<CR>
Response	<value><CR> OK<CR>

**7.4 Network Specific Parameters****7.4.1 AT+CHMASK or AT+CM**

Description	Get/Set the channel mask to use. Bits set as 1 indicate that this particular channel can be used. Bits set as 0 indicate that this particular channel should not be used. For example, a channel mask value of 0x00000001 indicates that only channel 0 should be used. Valid channels range from 11 to 26 inclusive. (16 channels are available.) This translates to a channel mask value of "0x07FFF800".	
Execute	AT+CHMASK?<CR>	AT+CHMASK=<value><CR>
Response	<value><CR> OK<CR>	OK<CR> or ERROR<CR>
Default	07FFF800	

Range	00000800 - 07FFF800
-------	---------------------

**7.4.2 AT+PANID or AT+PI**

Description	Get/Set the 16-bit PAN ID. If it is set to 0s at a coordinator, the coordinator will select a random 16-bit hexadecimal number as PAN ID. If it is set to 0s at a router/end-device, the router/end-device will try to join any existing network regardless of PAN ID.	
Execute	AT+PANID?<CR>	AT+PANID=<value><CR>
Response	<value><CR> OK<CR>	OK<CR> or ERROR<CR>
Default	0000	
Range	0000 – FFFF	

**7.4.3 AT+EPID or AT+EI**

Description	Get/Set the 64-bit extended PAN ID. If the node is a coordinator and the EPID is set to 0s, it will create new extended PAN ID using its 64-bit IEEE address as extended PAN ID. If the node is a router or end-device and the EPID is set to 0x, it will try to join any existing network regardless of extended PAN ID.	
Execute	AT+EPID?<CR>	AT+EPID=<value><CR>
Response	<value><CR> OK<CR>	OK<CR> or ERROR<CR>
Default	0000000000000000	
Range	0000000000000000 - FFFFFFFFFFFFFFFF	

**7.4.4 AT+GROUPID or AT+GI**

Description	Get/Set the 16-bit Group ID. It is used for multicast data reception.	
Execute	AT+GROUPID?<CR>	AT+GROUPID=<value><CR>
Response	<value><CR> OK<CR>	OK<CR> or ERROR<CR>
Default	0000	
Range	0000 - FFFF	

**7.4.5 AT+POWER or AT+PW**

Description	Get/Set the TX power at which the RF module transmits conducted power.	
Execute	AT+POWER?<CR>	AT+POWER=<value><CR>
Response	<value><CR> OK<CR>	OK<CR> or ERROR<CR>
Default	8	
Range	-43 - 8	



**7.4.6 AT+STACK or AT+ZS**

Description	Get/Set the ZigBee stack profile value. This value must be set the same on all devices that should join the same network. (0: Network specific, 1: ZigBee, 2: ZigBee Pro)	
Execute	AT+STACK?<CR>	AT+STACK=<value><CR>
Response	<value><CR> OK<CR>	OK<CR> or ERROR<CR>
Default	0	
Range	0 - 2	

**7.4.7 AT+NODENAME or AT+NN**

Description	Get/Set the node name. It can be used to make a clear distinction role or functionality of local node from others.	
Execute	AT+NODENAME?<CR>	AT+NODENAME=<value><CR>
Response	<value><CR> OK<CR>	OK<CR> or ERROR<CR>
Default	ProBee-ZE	
Range	Up to 16 characters	

**7.5 Network Formation and Join**

**7.5.1 AT+ASCAN or AT+AS**

Description	Perform a scanning for existing network. It can take up to 5 seconds. ( <i>CAUTION: It is possible to cause a link error if a node is a parent of an end-device.</i> )	
Execute	AT+ASCAN<CR>	AT+ASCAN=<channel mask><CR>
Response	<channel> <PAN ID> <EPID> <joinable> <stack profile> <i>List of the existing networks ...</i> OK<CR>	

**7.5.2 AT+ESCAN or AT+ES**

Description	Perform a scanning for energy level of all channels. It can be used to avoid interference. It can take up to 5 seconds. The RSSI energy level ranges from approximately -100 to +127 in dBm. ( <i>CAUTION: It is possible to cause a link error if a node is a parent of an end-device.</i> )	
Execute	AT+ESCAN<CR>	AT+ESCAN=<channel mask><CR>
Response	<channel> <RSSI > <i>List of the RSSI for each channel ...</i> OK<CR>	

**7.5.3 AT+DSCAN or AT+DS**

Description	Perform a scanning for existing nodes in the current network. A coordinator or router can have children nodes and they are presented by “CLDn”. It can be possible to place some conditions such as scan duration, node type and node name in order. The information of local node is presented by “*”. <i>(CAUTION: A ProBee-Z*10 with PTV1.2 or earlier cannot receive the response of AT+DSCAN from any ProBee-Z*10 with PTV1.3 or later. It cannot receive from any ProBee-Z*20, either. In this case, it is recommended to upgrade PTV1.2 to the latest version.)</i>
Execute	AT+DSCAN<CR> or AT+DSCAN=<scan duration><CR> or AT+DSCAN=<scan duration>,<node type><CR> or AT+DSCAN=<scan duration>,<node type>,<node name><CR>
Response	<node type> <IEEE address> <node ID> <version> <product name> <node name> <i>List of the existing nodes and information...</i> OK<CR>
Range	Scan duration: 1 – 10 Node type: 0 – 4 (Zero indicates all node types.)

**7.5.4 AT+RSSI or AT+RS**

Description	Get RSSI and LQI information respectively for the delivery of the recent packet across the last hop of the incoming route. The LQI value ranges from 0 to 255 with the maximum value representing the best possible link quality. The RSSI value ranges from approximately -100 to +127 with each value representing the energy level in dBm at the radio’s receiver. The sender of the recent packet and the parent are also displayed.
Execute	AT+RSSI?<CR>
Response	Sender: <node ID>, Parent: FFFF, RSSI: <RSSI value>, LQI: <LQI value><CR> OK<CR>

**7.5.5 AT+NODETYPE or AT+NT**

Description	Get/Set the node type. (0: none, 1: coordinator, 2: router, 3: end-device, 4: sleepy end-device)	
Execute	AT+NODETYPE?<CR>	AT+NODETYPE=<value><CR>
Response	<value><CR> OK<CR>	OK<CR> or ERROR<CR>
Default	0	
Range	0 - 4	

**7.5.6 AT+PERMIT or AT+PJ**

Description	Permit other nodes to join the network. (0~254s, 255=continuance) An end-device cannot perform it.	
Execute	AT+PERMIT<CR>	AT+PERMIT=<value><CR>
Response	OK<CR>	
Range	0 - 255	

**7.5.7 AT+LEAVE or AT+LV**

Description	Leave the current network.	
Execute	AT+LEAVE<CR>	
Response	OK<CR>	

**7.6 End-device****7.6.1 AT+SLEEP or AT+SM**

Description	Enter the sleep mode immediately if the node is a sleepy end-device.	
Execute	AT+SLEEP<CR>	
Response	OK<CR>	

**7.6.2 AT+PARENTLA or AT+PL**

Description	Get the 64-bit IEEE address of the parent node.	
Execute	AT+PARENTLA?<CR>	
Response	<IEEE address><CR> OK<CR>	

**7.6.3 AT+PARENTSA or AT+PS**

Description	Get the 16-bit Node ID of the parent node.	
Execute	AT+PARENTSA?<CR>	
Response	<node ID><CR> OK<CR>	

**7.6.4 AT+CHILDTABLE or AT+CT**

Description	Get the child table composed of the end-devices.	
Execute	AT+CHILDTABLE?<CR>	
Response	<node type> <IEEE address> <node ID> <i>List of the child nodes...</i> OK<CR>	

## 7.7 Data Transmission and Reception

### 7.7.1 AT+DESTLA or AT+DL

Description	Get/Set the 64-bit destination IEEE address for unicast data transmission.	
Execute	AT+DESTLA?<CR>	AT+DESTLA=<value><CR>
Response	<value><CR> OK<CR>	OK<CR> or ERROR<CR>
Default	0000000000000000	
Range	0000000000000000 - FFFFFFFF	

### 7.7.2 AT+DESTGROUPID or AT+DG

Description	Get/Set the 16-bit destination Group ID for multicast data transmission.	
Execute	AT+DESTGROUPID?<CR>	AT+ DESTGROUPID=<value><CR>
Response	<value><CR> OK<CR>	OK<CR> or ERROR<CR>
Default	0000	
Range	0000 – FFFF	

### 7.7.3 AT+SINKINFO or AT+SI

Description	Get the long and short addresses of sink node. If there is no sink node in the network, the addresses will be “FFFFFFFFFFFFFFFF” and “FFFF”.	
Execute	AT+SINKINFO?<CR>	
Response	<IEEE address>,<nodeID><CR> OK<CR>	

### 7.7.4 AT+MAXPAYLOAD or AT+MP

Description	Get the maximum size of the payload that the Application Support sub-layer will accept. The size depends on the security level in use.	
Execute	AT+MAXPAYLOAD?<CR>	
Response	<value><CR> OK<CR>	

### 7.7.5 AT+TRANSMITMODE or AT+TM

Description	Get/Set the data transmission mode. This mode is maintained after rebooting. (0: none, 1: unicast to destination long address, 2: multicast to destination group ID, 3: broadcast to all nodes, 4: unicast to sink node)	
Execute	AT+TRANSMITMODE?<CR>	AT+TRANSMITMODE=<value><CR>
Response	<value><CR> OK<CR>	OK<CR> or ERROR<CR>
Default	0	

Range	0 - 4
-------	-------

### 7.7.6 AT+UNICAST or AT+UC

Description	Send unicast message to specific node using long or short address of remote node. Up to 90 bytes (or 72 bytes when security enabled) are sent to the node at once.	
Execute	AT+UNICAST=<IEEE>,<data><CR>	AT+UNICAST=<nodeID>,<data><CR>
Response	OK<CR>	

### 7.7.7 AT+MULTICAST or AT+MC

Description	Send multicast message to specific group. Every node belongs to the group after being booted up if it is designated to a group ID (AT+GROUPID).	
Execute	AT+MULTICAST=<groupID>,<data><CR>	
Response	OK<CR>	

### 7.7.8 AT+BROADCAST or AT+BC

Description	Send broadcast message to the all nodes joining the network. Transmission range is determined by broadcast range (S35).	
Execute	AT+BROADCAST=<data><CR>	
Response	OK<CR>	

### 7.7.9 AT+REMOTE or AT+RC

Description	Get/Set the configuration values of remote node using long or short address. AT+REMOTE<CR> shows the list of available commands.	
Execute	AT+REMOTE=<addr>,<cmd>?<CR>	AT+REMOTE=<addr>,<cmd>=<value><CR>
Response	<value><CR> OK<CR>	OK<CR>

## 7.8 Security

### 7.8.1 AT+SECURITY or AT+SE

Description	Get/Set the security status. (0: turning security off, 1: on) Every node must be under the same security level in the network.	
Execute	AT+SECURITY?<CR>	AT+SECURITY=<value><CR>
Response	<value><CR> OK<CR>	OK<CR> or ERROR<CR>
Default	0	
Range	0 - 1	

### 7.8.2 AT+LINKKEY or AT+LK

Description	Get/Set the 128-bit link key. (0 or 0s: generate 128-bit random number)
-------------	---

Execute	AT+LINKKEY?<CR>	AT+LINKKEY=<value><CR>
Response	<value><CR> OK<CR>	OK<CR> or ERROR<CR>
Default	FFFFFFFFFFFFFFFFFFFFFFFFFFFFFFFF	

**7.8.3 AT+NWKKEY or AT+NK**

Description	Get/Set the 128-bit network key. (0 or 0s: generate random 128-bit number)	
Execute	AT+NWKKEY?<CR>	AT+NWKKEY=<value><CR>
Response	<value><CR> OK<CR>	OK<CR> or ERROR<CR>
Default	FFFFFFFFFFFFFFFFFFFFFFFFFFFFFFFF	

**7.8.4 AT+UPDATEKEY or AT+UK**

Description	Update the network key with a new generated key. (possible only for coordinator) It is applied after 30s later because sending too quickly may cause a sleepy end-device to miss the alternate encryption key and only get the switch key message, which means it will be unable to change to the new network key.	
Execute	AT+UPDATEKEY<CR>	
Response	OK<CR> or ERROR<CR>	

**7.9 UART**

**7.9.1 AT+BAUDRATE or AT+UB**

Description	Get/Set the serial port speed for communication between the module serial port and host.	
Execute	AT+BAUDRATE?<CR>	AT+BAUDRATE=<value><CR>
Response	<value><CR> OK<CR>	OK<CR> or ERROR<CR>
Default	9600	
Range	300 - 230400	

**7.9.2 AT+DATABIT or AT+UD**

Description	Get/Set the serial data bit setting on the module.	
Execute	AT+DATABIT?<CR>	AT+DATABIT=<value><CR>
Response	<value><CR> OK<CR>	OK<CR> or ERROR<CR>
Default	8	
Range	7 - 8	

**7.9.3 AT+PARITY or AT+UP**

Description	Get/Set the serial parity setting on the module.	
Execute	AT+PARITY?<CR>	AT+PARITY=<value><CR>
Response	<value><CR> OK<CR>	OK<CR> or ERROR<CR>
Default	0	
Range	0 - 2	

**7.9.4 AT+STOPBIT or AT+US**

Description	Get/Set the serial stop bit setting on the module.	
Execute	AT+STOPBIT?<CR>	AT+STOPBIT=<value><CR>
Response	<value><CR> OK<CR>	OK<CR> or ERROR<CR>
Default	1	
Range	1 - 2	

**7.9.5 AT+FLOWCTRL or AT+UF**

Description	Get/Set flow control status. (0: none, 1: software, 2: hardware flow control)	
Execute	AT+FLOWCTRL?<CR>	AT+FLOWCTRL=<value><CR>
Response	<value><CR> OK<CR>	OK<CR> or ERROR<CR>
Default	0	
Range	0 - 2	

**7.10 GPIO****7.10.1 AT+GPIO or AT+IO**

Description	Get/Set the configuration status of GPIO individually or all at once. Only GPIO9-14 can be set 0-5, others are available 0-3 and 5.	
Execute	AT+GPIO?<CR> or AT+GPIO<number>?<CR>	AT+GPIO=<values><CR> or AT+GPIO<number>=<value><CR>
Response	<value><CR> OK<CR>	OK<CR> or ERROR<CR>
Default	5555500000000055	
Range	GPIO9-14: 0-5, the others: 0-3 and 5 0 Disabled (unmonitored digital input) 1 Digital input, monitored 2 Digital output, default low 3 Digital output, default high 4 Analog input, single ended (only valid for GPIO3~6)	

	5 Reserved for pin-specific alternate functionalities (See Table 5-2)
--	---

**7.10.2 AT+DIO**

Description	Get/Set the digital IO value individually or all at once. All GPIO pins can be used as digital IO and it is only possible to set 0 or 1. If there are some pins used analog input, they are displayed by “*”.	
Execute	AT+DIO?<CR> or AT+DIO<number>?<CR>	AT+DIO=<values><CR> or AT+DIO<number>=<value><CR>
Response	<value><CR> OK<CR>	OK<CR> or ERROR<CR>
Default	0000000000000000	
Range	0000000000000000 – 1111111111111111	

**7.10.3 AT+AI**

Description	Get the analog input value individually or all at once. GPIO9~14 are possible to set ADC and it’s read only. If there are some pins used digital IO, they are displayed by “****”.	
Execute	AT+AI?<CR>	AT+AI<number>?<CR>
Response	<value>,<value>,<value>,<value><CR> OK<CR>	<value><CR> OK<CR>

**7.10.4 AT+ SOURCELA or AT+SL**

Description	Get/Set the 64-bit source IEEE address for GPIO remote control. It is possible to limit on the implementation of this functionality by setting specific address. If set to default value, “FFFFFFFFFFFFFFFF”, the node allows that any node can control the GPIO status.	
Execute	AT+SOURCELA?<CR>	AT+SOURCELA=<value><CR>
Response	<value><CR> OK<CR>	OK<CR> or ERROR<CR>
Default	FFFFFFFFFFFFFFFF	
Range	0000000000000000 – FFFFFFFFFFFFFFFFFF	

**7.11 Firmware Upload and Help**

**7.11.1 AT+BOOTLOAD or AT+BL**

Description	Start bootloader to upload firmware. (blank: local, 1: passthru) The device leaves the AT command line and enters the bootloader menu for uploading new ProBee firmware. There’s no restrict to use local upload but a sleepy end-device cannot upload to remote node over the air. The current UART should be set 115200bps, 8 data bits, no parity, 1 stop bit and none flow control.
-------------	--



Execute	AT+BOOTLOAD<CR>	AT+BOOTLOAD=<number>,<IEEE><CR>
Response	<i>Bootloader menu</i> ... Serial upload complete	Please start .ebl upload image ...<CR> or Start cloning ...<CR> <i>Bootloader menu</i> ... Bootload Complete!

### 7.11.2 AT+HELP or AT+HP

Description	Show all the available commands
Execute	AT+HELP<CR>
Response	Available AT Commands ... OK<CR>

## 8 AT Command Examples

### 8.1 Network configuration

#### 8.1.1 Coordinator

```
AT+NODETYPE=1<CR>      # set node type (coordinator)
OK                      # Response
ATZ<CR>                # Apply the change
OK                      # Response
```

#### 8.1.2 Router

```
AT+NODETYPE=2<CR>      # set node type (router)
OK                      # Response
ATZ<CR>                # Apply the change
OK                      # Response
```

#### 8.1.3 End-device

```
AT+NODETYPE=3<CR>      # set node type (end-device)
OK                      # Response
ATZ<CR>                # Apply the change
OK                      # Response
```

#### 8.1.4 Sleepy End-device

```
AT+NODETYPE=4<CR>      # set node type (sleepy end-device)
OK                      # Response
ATZ<CR>                # Apply the change
OK                      # Response
```

#### 8.1.5 Specifying Network

```
AT+CHMASK=1000<CR>     # set 32-bit channel mask (ch: 12)
OK                      # Response
AT+PANID=0001 <CR>     # set 16-bit PAN ID (0001)
OK                      # Response
AT+EPID=0000000000000001<CR> # set 64-bit extended PAN ID (0000000000000001)
OK                      # Response
AT+ADDRDISCOVERY=1FEF<CR> # get 64-bit address using 16-bit short address
```

```

00019500002FDC15
OK # Response
AT+REMOTE=1FEF,AT+LONGADDR<CR> # get 64-bit address of remote node (1FEF)
00019500002FDC15
OK # Response
AT+DSCAN<CR> # get the information of other nodes in the network
                # (Response from ZE10 Node with PTV1.2 or earlier)
ZC*|00019500002FDC40|0000|PTv1.0|ZE10|ZE10_COM3
ZR |00019500002FDC15|1FEF|PTv1.0|ZE10|ZE10_COM4
CLD0|00019500002FDC17
CLD1|00019500002FDC14
ZED|00019500002FDC17|7E34|PTv1.0|ZS10|ZS10_COM5
SED|00019500002FDC14|F5AC|PTv1.0|ZU10|ZU10_COM6
OK # Response

```

cf:

```

AT+DSCAN<CR> # get the information of other nodes in the network
                # (Response from ZE10 Node with PTV1.3 or later
                # or ZE20 Node)
ZC*|00019500002FDC40|0000|PTv1.3|ZE20S|ZE20S_COM3
ZR |00019500002FDC15|1FEF|PTv1.3|ZE20S|ZE20S_COM4
CLD0|7E34
CLD1|F5AC
ZED|00019500002FDC17|7E34|PTv1.3|ZS10|ZS10_COM5
SED|00019500002FDC14|F5AC|PTv1.3|ZU10|ZU10_COM6
OK # Response

```

## 8.2 Data Transmission

### 8.2.1 Command Mode

```

# send unicast message(MSG01) to specific node using 64-bit long
address(0x00019500002FDC15)
AT+UNICAST=00019500002FDC15,MSG01<CR>
OK # Response
# send unicast message(MSG02) to specific node using 16-bit short
address(0x1FEF)
AT+UNICAST=1FEF,MSG02<CR>
OK # Response
# send multicast message(MSG03) to specific group(0001)

```

```

AT+MULTICAST=0001,MSG03<CR>
OK                               # Response
# send broadcast message(MSG04) to current network and the range is
determined by S35.
AT+BROADCAST=MSG04<CR>
OK                               # Response

```

### 8.2.2 Data Mode

```

ATD<CR>                          # enter the unicast mode using destination long address
OK                               # Response
MSG05+++                          # send data(MSG05) and leave data mode
ATD0000<CR>                      # enter the unicast mode using 16-bit short address
OK                               # Response
MSG06+++                          # send data(MSG06) and leave data mode
ATD00019500002FDC40<CR>         # enter the unicast mode using 64-bit long address
OK                               # Response
MSG07+++                          # send data(MSG07) and leave data mode
ATM<CR>                          # enter the multicast mode using destination group ID
OK                               # Response
MSG08+++                          # send data(MSG08) and leave data mode
ATM0001<CR>                      # enter the multicast mode using 16-bit group ID
OK                               # Response
MSG09+++                          # send data(MSG09) and leave data mode
ATB<CR>                          # enter the broadcast mode
OK                               # Response
MSG10+++                          # send data(MSG10) and leave data mode
AT+TRANSMITMODE=1<CR>          # set transmission mode
OK                               # Response
ATZ<CR>                          # Apply the change
OK                               # Response
MSG11+++                          # send data(MSG11) and leave data mode
ATO<CR>                          # return to the current data mode

```

### 8.3 Security

```

AT+SECURITY=1<CR>              # set security level (ON)
OK                               # Response

```

```

AT+LINKKEY=5A46...21<CR> # set the 128-bit trust center link key (5A46...21)
ATZ<CR> # Apply the change
OK # Response
AT+NWKEY=0<CR> # set the 128-bit network key (random key)
OK # Response
AT+UPDATEKEY<CR> # update the changed network key
OK # Response

```

## 8.4 UART Settings

```

AT+BAUDRATE=115200<CR> # set baud rate (115,200bps)
OK # Response
AT+DATABIT=8<CR> # set data bit (8bit)
OK # Response
AT+PARITY=0<CR> # set parity (none)
OK # Response
AT+STOPBIT=1<CR> # set stop bit (1bit)
OK # Response
AT+FLOWCTRL=2<CR> # set flow control (hardware)
OK # Response
ATZ<CR> # Apply the change
OK # Response

```

## 8.5 GPIO

```

AT+GPIO=55003300000441122<CR> # set GPIO configuration
OK # Response
ATZ<CR> # Apply the change
OK # Response
AT+GPIO0<CR> # check the current GPIO status (GPIO0)
5
OK # Response
AT+DIO<CR> # check the current DIO value
1000000000**0011
OK # Response
AT+AI<CR> # check the current AI value
****,****,1786,23A2,****,****
OK # Response

```

## 8.6 Firmware Upload

### 8.6.1 Local Node

```
# enter the bootloader menu for uploading firmware. Note that UART of local
node should be set to 115200-8-N-1-N.
AT+BOOTLOAD<CR>
Press ENTER...

SENA ProBee Bootloader v1.0
1. Upload Firmware
2. Run
3. View Firmware info
PROBEE > # press "1" and upload ebl file by X-modem
begin upload
CCCCCCCCCCCCC
Serial upload complete # press "2" or reset after upload is done
```

### 8.6.2 Remote Node

```
# upload firmware to a remote node using 64-bit long address. Note that UART
of local node should be set to 115200-8-N-1-N.
AT+BOOTLOAD=1,00019500002FDC40<CR>
Please start .ebl upload image ...
CCCCCCCCCCCCC # upload ebl file by X-modem
Bootload Complete! # succeed to upload
```

## 9 S-Registers

Register number	Descriptions
11	Display incoming message in command mode
12	Display command echo
13	Display command responses
14	Manage LED status
21	Inter character timeout
22	Permit joining timeout
23	TX power mode
31	Enable application-ACK
32	Transmission retries
33	Transmission timeout
34	Indirect transmission timeout
35	Broadcast range
36	Number of hops for multicast/broadcast
37	Number of hops of nonmembers for multicast
38	Receive local message for multicast/broadcast
39	Receive message by own data mode
41	GPIO pull-up
42	GPIO monitoring period
43	GPIO monitoring node
44	GPIO change detection sampling
45	GPIO remote control
51	Poll timeout for a parent node
52	Poll period for a sleepy end-device
53	Sleep duration
54	Standby timeout
55	Rejoin timeout
56	Poll period for an end-device
61	Sink advertise period
62	Many to one route request period
71	Enable Frequency agility

## 9.1 Display Options

### 9.1.1 S11

Description	Get/Set the display mode. It determines to display incoming message in command mode.	
Execute	ATS11?<CR>	ATS11=<value><CR>
Response	<value><CR> OK<CR>	OK<CR>
Default	1	
Range	0 - 1	

### 9.1.2 S12

Description	Get/Set the command echo mode.	
Execute	ATS12?<CR>	ATS12=<value><CR>
Response	<value><CR> OK<CR>	OK<CR>
Default	1	
Range	0 – 1	

### 9.1.3 S13

Description	Get/Set the command responses mode.	
Execute	ATS13?<CR>	ATS13=<value><CR>
Response	<value><CR> OK<CR>	OK<CR>
Default	1	
Range	0 - 1	

### 9.1.4 S14

Description	Get/Set the LED mode. It causes the LED operation if the device is ZE20S set GPIO15, 16 to specific functionality.  0: LEDs are always OFF regardless of configuration or status. 1: LEDs are OFF when the node is under sleep status. 2: LEDs always operate by the case.	
Execute	ATS14?<CR>	ATS14=<value><CR>
Response	<value><CR> OK<CR>	OK<CR>
Default	1	
Range	0 - 2	



## 9.2 Network Settings

### 9.2.1 S21

Description	Get/Set the inter character timeout in milliseconds. It determines to send data packet after this time.	
Execute	ATS21?<CR>	ATS21=<value><CR>
Response	<value><CR> OK<CR>	OK<CR>
Default	100	
Range	0 - 10000	

### 9.2.2 S22

Description	Get/Set the timeout to permit joining. It determines the time in seconds that the device will allow other devices to join to it when it starts network but an end-device cannot perform it. If set to 255, the device will always permit joining.	
Execute	ATS22?<CR>	ATS22=<value><CR>
Response	<value><CR> OK<CR>	OK<CR>
Default	255	
Range	0 - 255	

### 9.2.3 S23

Description	Get/Set the power boost mode of the module. If enabled, boost mode improves sensitivity and increases output power, improving the link margin and range.	
Execute	ATS23?<CR>	ATS23=<value><CR>
Response	<value><CR> OK<CR>	OK<CR>
Default	0	
Range	0 – 1	

## 9.3 Data Transmissions

### 9.3.1 S31

Description	Get/Set the application-ACK mode. If it is enabled, a sender node retransmits data packet when it fails to receive ACK from receiver node. This value must be set same on the source and destination node for data transmission.	
Execute	ATS31?<CR>	ATS31=<value><CR>
Response	<value><CR> OK<CR>	OK<CR>
Default	1	
Range	0 - 1	

**9.3.2 S32**

Description	Get/Set the transmission retries. A sender tries to retransmit up to this value when transmission fails. ( <i>CAUTION: It is recommended to set the smallest value that the application can tolerate in broadcast/multicast data transmission.</i> )	
Execute	ATS32?<CR>	ATS32=<value><CR>
Response	<value><CR> OK<CR>	OK<CR>
Default	5	
Range	0 – 99	

**9.3.3 S33**

Description	Get/Set the transmission timeout in milliseconds. A sender retransmits data packet after this time when transmission fails. ( <i>CAUTION: It is recommended to set this value more than 1000 in broadcast/multicast data transmission.</i> )	
Execute	ATS33?<CR>	ATS33=<value><CR>
Response	<value><CR> OK<CR>	OK<CR>
Default	500	
Range	0 – 10000	

**9.3.4 S34**

Description	Get/Set the indirect transmission timeout in milliseconds. It is the maximum amount of time that the MAC will hold a message for indirect transmission to a child.	
Execute	ATS34?<CR>	ATS34=<value><CR>
Response	<value><CR> OK<CR>	OK<CR>
Default	3000	
Range	0 – 30000	

**9.3.5 S35**

Description	<p>Get/Set the broadcast range. ZigBee specifies three different broadcast addresses that reach different collections of nodes. Broadcasts are normally sent only to routers. Broadcasts can also be forwarded to end-devices, either all of them or only those that do not sleep. Broadcasting to sleepy end-devices is both significantly more resource-intensive and significantly less reliable than broadcasting to routers.</p> <p>0: send to all routers 1: send to all non-sleepy nodes</p>
-------------	---

	2: send to all nodes in the network	
Execute	ATS35?<CR>	ATS35=<value><CR>
Response	<value><CR> OK<CR>	OK<CR>
Default	2	
Range	0 – 2	

**9.3.6 S36**

Description	Get/Set the maximum number of hops the message will be relayed. The message will be delivered to all nodes within this number of hops of the sender. A value of zero is converted to maximum value(30). It is used to multicast/broadcast.	
Execute	ATS36?<CR>	ATS36=<value><CR>
Response	<value><CR> OK<CR>	OK<CR>
Default	0	
Range	0 – 30	

**9.3.7 S37**

Description	Get/Set the number of hops that the message will be forwarded by devices that are not members of the group. A value of zero, 7 or greater is treated as infinite.	
Execute	ATS37?<CR>	ATS37=<value><CR>
Response	<value><CR> OK<CR>	OK<CR>
Default	0	
Range	0 – 7	

**9.3.8 S38**

Description	Get/Set the receive message mode. If it is enabled, a local node will receive multicast or broadcast messages from itself.	
Execute	ATS38?<CR>	ATS38=<value><CR>
Response	<value><CR> OK<CR>	OK<CR>
Default	0	
Range	0 – 1	

**9.3.9 S39**

Description	Get/Set the receive mode. If S39 is enabled, a local node will only receive the same type of messages with its transmission mode. For example, if local node's transmission mode is broadcast mode (AT+TM=3), it will receive only broadcast	
-------------	--	--

	messages and won't receive unicast or multicast messages.	
Execute	ATS39?<CR>	ATS39 =<value><CR>
Response	<value><CR> OK<CR>	OK<CR>
Default	0	
Range	0 - 1	

## 9.4 GPIO

### 9.4.1 S41

Description	Get/Set the GPIO pull up/down option. If GPIOs are set to DI(Digital Input), it is possible to pull-up or pull-down with this value. Pull-down = 0, Pull-up = 1.	
Execute	ATS41?<CR>	ATS41=<value><CR>
Response	<value><CR> OK<CR>	OK<CR>
Default	0	
Range	0 - 1	

### 9.4.2 S42

Description	Get/Set the GPIO monitoring period in seconds. If it is enabled, a node sends GPIO values to a remote node based on preconfigured destination IEEE address periodically and it is possible to monitor the GPIO status at the remote node. A remote node can also be the sink node according to GPIO monitoring node (S43). If set to 0, GPIO monitoring is disabled.	
Execute	ATS42?<CR>	ATS42=<value><CR>
Response	<value><CR> OK<CR>	OK<CR>
Default	0	
Range	0 – 10000	

### 9.4.3 S43

Description	Get/Set the GPIO monitoring node. If S43 is 0, the monitoring node is selected by AT+DESTLA or AT+DL command. If S43 is 1, the sink node is set as the monitoring node.	
Execute	ATS43?<CR>	ATS43=<value><CR>
Response	<value><CR> OK<CR>	OK<CR>
Default	0	
Range	0 – 10000	

**9.4.4 S44**

Description	Get/Set the GPIO change detection sampling mode. If it is enabled, a node sends GPIO values to a remote node based on preconfigured destination IEEE address immediately when the status of GPIO changes. A remote node can also be the sink node according to GPIO monitoring node (S43). If set to 0, GPIO change detection sampling is disabled.	
Execute	ATS44?<CR>	ATS44=<value><CR>
Response	<value><CR> OK<CR>	OK<CR>
Default	0	
Range	0 – 1	

**9.4.5 S45**

Description	Get/Set the GPIO remote control mode. If any GPIO pin is set to digital input, a node can control the I/O status of a remote node if the I/O pin of the remote node is set to digital output. It is possible to use when GPIO monitoring is enabled (GPIO monitoring period, S42 > 0) or GPIO change detection sampling is enabled.(GPIO change detection sampling mode, S44 = 1)	
Execute	ATS45?<CR>	ATS45=<value><CR>
Response	<value><CR> OK<CR>	OK<CR>
Default	0	
Range	0 – 1	

**9.5 End-Device****9.5.1 S51**

Description	Get/Set the poll timeout for a parent node in seconds. If an end-device or a sleepy end-device does not send a poll request to its parent coordinator or router within the poll timeout, the end-device is removed from the child table.	
Execute	ATS51?<CR>	ATS51=<value><CR>
Response	<value><CR> OK<CR>	OK<CR>
Default	60	
Range	0 – 4177920	

**9.5.2 S52**

Description	Get/Set the sleepy end-device poll period in milliseconds. Adaptive polling may allow the sleepy end-device to poll more rapidly for a short time when receiving RF data.	
Execute	ATS52?<CR>	ATS52=<value><CR>

Response	<value><CR> OK<CR>	OK<CR>
Default	100	
Range	0 - 10000	

### 9.5.3 S53

Description	Get/Set the sleep duration in quarter seconds. An end-device sleeps for this time and turns off radio every sleep cycle. If a node sleeps over poll timeout of parent node, the device will be removed from the child table.	
Execute	ATS53?<CR>	ATS53=<value><CR>
Response	<value><CR> OK<CR>	OK<CR>
Default	8	
Range	0 – 16711680	

### 9.5.4 S54

Description	Get/Set the standby timeout in seconds. When an end-device wakes up and polls with the parent node, the node will wait for another data from the ZigBee network or from the serial port for S54 before it goes to sleep mode again. If any serial or RF data is sent or received, the timer will reset and wait for next again.	
Execute	ATS54?<CR>	ATS54=<value><CR>
Response	<value><CR> OK<CR>	OK<CR>
Default	5	
Range	0 – 10000	

### 9.5.5 S55

Description	Get/Set the rejoin timeout. If it is enabled, an end-device tries to rejoin the current network when contact with the network has been lost for setting value in seconds. The most common usage case is when an end-device can no longer communicate with its parent and wishes to find a new one. A value of zero, don't try to rejoin.	
Execute	ATS55?<CR>	ATS55=<value><CR>
Response	<value><CR> OK<CR>	OK<CR>
Default	10	
Range	0 – 10000	

### 9.5.6 S56

Description	Get/Set the end-device poll period in seconds. Adaptive polling may allow the end-	
-------------	--	--

	device to poll more rapidly for a short time when receiving RF data.	
Execute	ATS56?<CR>	ATS56=<value><CR>
Response	<value><CR> OK<CR>	OK<CR>
Default	5	
Range	0 - 10000	

## 9.6 Sink

### 9.6.1 S61

Description	Get/Set the sink node and the sink advertise period in seconds. When a node is defined as a sink, it can multicast its address to the rest of the network in this period. If set to 0, sink advertise is disabled.	
Execute	ATS61?<CR>	ATS61=<value><CR>
Response	<value><CR> OK<CR>	OK<CR>
Default	0	
Range	0 – 10000	

### 9.6.2 S62

Description	Get/Set the period to send Many-to-One Route Request. Many-to-One Route Request (MTOR) creates routes from every node in the network back to this node. It is useful when this node acts as a sink node.	
Execute	ATS62?<CR>	ATS62=<value><CR>
Response	<value><CR> OK<CR>	OK<CR>
Default	0	
Range	0 – 10000	

## 9.7 Frequency Agility

### 9.7.1 S71

Description	Get/Set the Frequency agility function. If it is enabled in coordinator mode, node will automatically shift operating channel to one of channel masks when its unicasts fail more than threshold.	
Execute	ATS71?<CR>	ATS71=<value><CR>
Response	<value><CR> OK<CR>	OK<CR>
Default	0	
Range	0 – 1	

## 10 Pin Assignments

NO	Pin Assignment
1	GND
2	PC_5/FACTORY_RST
3	PC_6/GPIO0
4	PC_7/DTR/GPIO1
5	PA_7/DSR/GPIO2
6	PB_3/CTS/GPIO3
7	PB_4/RTS/GPIO4
8	PA_0/MOSI/GPIO5
9	PA_1/MISO/GPIO6
10	PA_2/SCLK/GPIO7
11	PA_3/nSSEL/GPIO8
12	VCC
13	GND

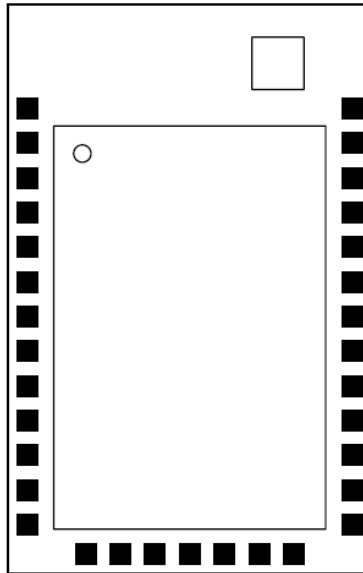

Pin Assignment	NO
GND	33
PB_5/ADC0/GPIO9	32
PB_6/ADC1/GPIO10	31
PB_7/ADC2/GPIO11	30
PC_1/ADC3/GPIO12	29
PA_4/ADC4/GPIO13	28
PA_5/ADC5/GPIO14	27
PB_1/TXD	26
PB_2/RXD	25
PB_0/GPIO15	24
PA_6/GPIO16	23
/RESET	22
GND	21

14	VCC
15	JTCK
16	PC_2/JTDO
17	PC_3/JTDI
18	PC_4/JTMS
19	PC_0/JRST
20	GND

Figure 10-1 Pin Assignments



Table 10-1 Pin Assignments Table

Pin	NAME	Default Function	Direction	Description
1	GND	-	-	Ground
2	Factory Reset	Factory Reset	IN	Digital I/O, Factory reset input, Active low
3	GPIO_0	Permit Joining	IN/OUT	Digital I/O, Permit joining input
4	GPIO_1	UART_DTR	IN/OUT	Digital I/O, UART_DTR
5	GPIO_2	UART_DSR	IN/OUT	Digital I/O, UART_DSR
6	GPIO_3	UART_CTS	IN/OUT	Digital I/O, UART_CTS
7	GPIO_4	UART_RTS	IN/OUT	Digital I/O, UART_RTS
8	GPIO_5	DIO_5	IN/OUT	Digital I/O
9	GPIO_6	DIO_6	IN/OUT	Digital I/O
10	GPIO_7	DIO_7	IN/OUT	Digital I/O
11	GPIO_8	DIO_8	IN/OUT	Digital I/O
12	VCC	-	IN	Power supply, 3.3V
13	GND	-	-	Ground
14	VCC	-	-	Power supply, 3.3V
15	JTCK	-	IN	JTAG clock input from debugger
16	JTDO	-	OUT	JTAG data output to debugger
17	JTDI	-	IN	JTAG data input from debugger
18	JTMS	-	IN	JTAG mode select from debugger
19	JRST	-	IN	JTAG reset input from debugger
20	GND	-	-	Ground
21	GND	-	-	Ground
22	/RESET	-	IN	H/W_/Reset, Active low
23	GPIO_16	Status LED	IN/OUT	Digital I/O, Status LED
24	GPIO_15	Power LED	IN/OUT	Digital I/O, Power LED
25	UART_RXD	UART_RXD	IN	UART Data Input
26	UART_TXD	UART_TXD	OUT	UART Data Output
27	GPIO_14 *	DIO_14	IN/OUT	Digital I/O / ADC_5
28	GPIO_13	DIO_13	IN/OUT	Digital I/O / ADC_4
29	GPIO_12	DIO_12	IN/OUT	Digital I/O / ADC_3
30	GPIO_11	DIO_11	IN/OUT	Digital I/O / ADC_2
31	GPIO_10	DIO_10	IN/OUT	Digital I/O / ADC_1
32	GPIO_9	DIO_9	IN/OUT	Digital I/O / ADC_0
33	GND	-	-	Ground

\* NOTE: GPIO\_14 is driven low at pin reset or power-on-reset, the module will boot up in bootloader.

## 11 Connections

### 11.1 Serial Port Pin Outs

ProBee-ZE20S starter kit is a DCE device compatible with the RS232 standard, a DB9 female interface.

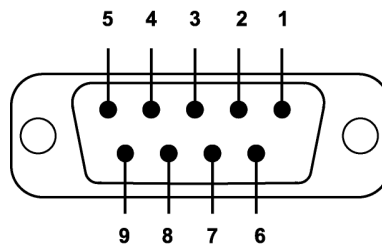

Figure 11-1 Pin layout of the DB-9 female connector

Table 11-1 Pin assignment of the DB-9 female connector

Pin #	Signal	Direction	Description
1	-	-	-
2	TxD	Output	Transmitted Data
3	RxD	Input	Received Data
4	DSR	Input	Data set ready
5	GND	-	Signal Ground
6	DTR	Output	Data terminal ready
7	CTS	Input	Clear to Send
8	RTS	Output	Ready to send
9	VCC	Input	(5V ~ 12V)

## 11.2 Serial Wiring Diagram

### 11.2.1 To Host with DTE Interface

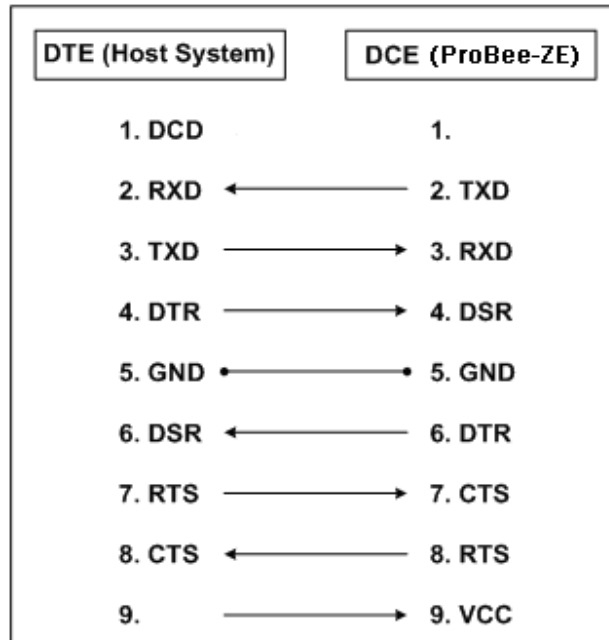

### 11.2.2 To Host with DCE Interface

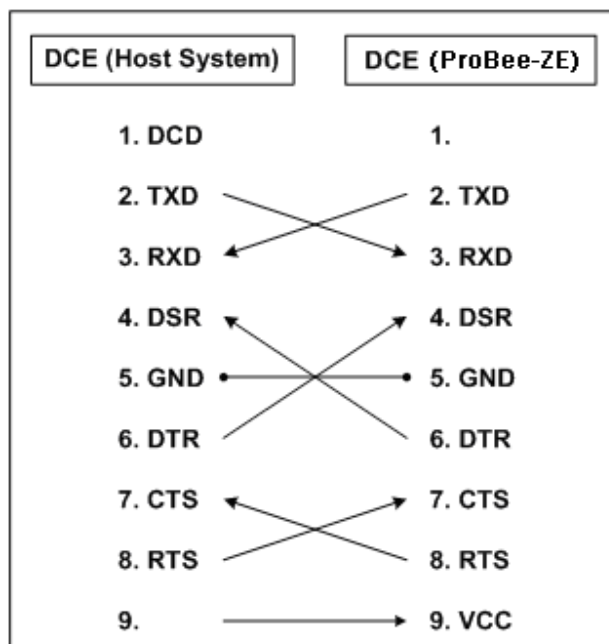

## 12 Mechanical Drawings

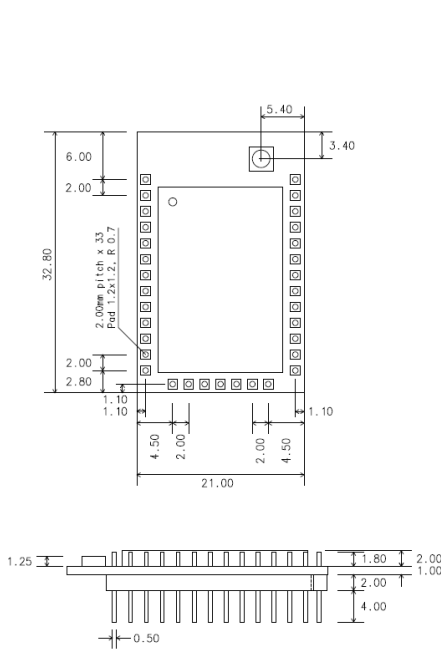

Figure 12-1 ProBee-ZE20SDU

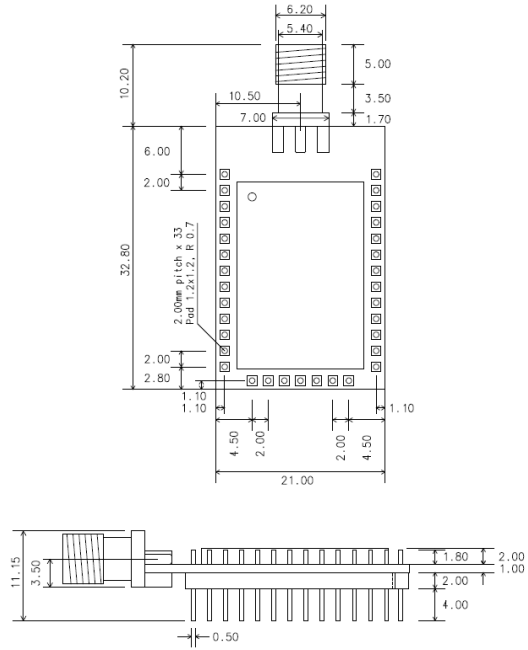

Figure 12-2 ProBee-ZE20SDS

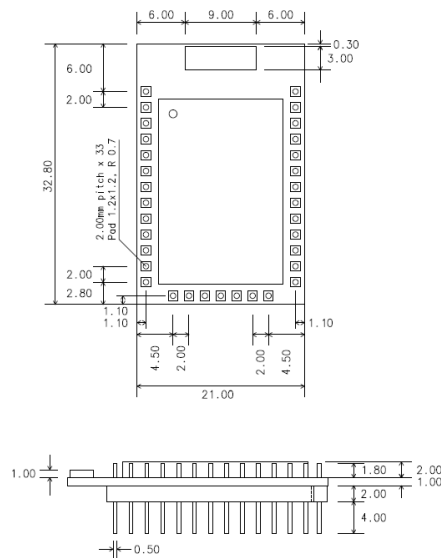

Figure 12-3 ProBee-ZE20SDC

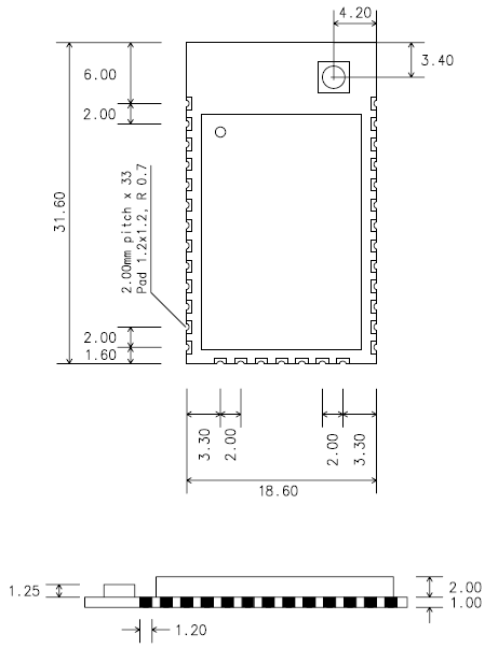

Figure 12-4 ProBee-ZE20SSU

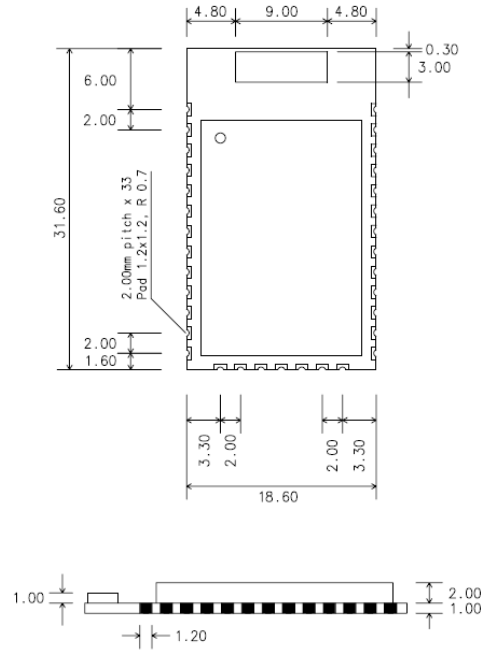

Figure 12-5 ProBee-ZE20SSC

## 13 Warranty

### 13.1 GENERAL WARRANTY POLICY

Sena Technologies, Inc. (hereinafter referred to as SENA) warrants that the Product shall conform to and perform in accordance with published technical specifications and the accompanying written materials, and shall be free of defects in materials and workmanship, for the period of time herein indicated, such warranty period commencing upon receipt of the Product.

This warranty is limited to the repair and/or replacement, at SENA's discretion, of defective or non-conforming Product, and SENA shall not be responsible for the failure of the Product to perform specified functions, or any other non-conformance caused by or attributable to: (a) any misapplication or misuse of the Product; (b) failure of Customer to adhere to any of SENA's specifications or instructions; (c) neglect of, abuse of, or accident to, the Product; or (d) any associated or complementary equipment or software not furnished by SENA.

Limited warranty service may be obtained by delivering the Product to SENA or to the international distributor it was purchased through and providing proof of purchase or receipt date. Customer agrees to insure the Product or assume the risk of loss or damage in transit, to prepay shipping charges to SENA, and to use the original shipping container or equivalent.

### 13.2 LIMITATION OF LIABILITY

EXCEPT AS EXPRESSLY PROVIDED HEREIN, SENA MAKES NO WARRANTY OF ANY KIND, EXPRESSED OR IMPLIED, WITH RESPECT TO ANY EQUIPMENT, PARTS OR SERVICES PROVIDED PURSUANT TO THIS AGREEMENT, INCLUDING BUT NOT LIMITED TO THE IMPLIED WARRANTIES OF MERCHANTABILITY AND FITNESS FOR A PARTICULAR PURPOSE. NEITHER SENA NOR ITS DEALER SHALL BE LIABLE FOR ANY OTHER DAMAGES, INCLUDING BUT NOT LIMITED TO DIRECT, INDIRECT, INCIDENTAL, SPECIAL OR CONSEQUENTIAL DAMAGES, WHETHER IN AN ACTION IN CONTRACT OR TORT (INCLUDING NEGLIGENCE AND STRICT LIABILITY), SUCH AS, BUT NOT LIMITED TO, LOSS OF ANTICIPATED PROFITS OR BENEFITS RESULTING FROM, OR ARISING OUT OF, OR IN CONNECTION WITH THE USE OF FURNISHING OF EQUIPMENT, PARTS OR SERVICES HEREUNDER OR THE PERFORMANCE, USE OR INABILITY TO USE THE SAME, EVEN IF SENA OR ITS DEALER HAS BEEN ADVISED OF THE POSSIBILITY OF SUCH DAMAGES. IN NO EVENT WILL SENA OR ITS DEALERS TOTAL LIABILITY EXCEED THE PRICE PAID FOR THE PRODUCT.

### 13.3 HARDWARE PRODUCT WARRANTY DETAILS

WARRANTY PERIOD: SENA warranties embedded hardware Product for a period of one (1) year, and external hardware Product for a period of three (3) or five (5) years according to the Product type.

WARRANTY PROCEDURE: Upon return of the hardware Product SENA will, at its option, repair or replace Product at no additional charge, freight prepaid, except as set forth below. Repair parts and replacement Product will be furnished on an exchange basis and will be either reconditioned or new. All replaced Product and parts become the property of SENA. If SENA determines that the Product is not under warranty, it will, at the Customers option, repair the Product using current SENA standard rates for parts and labor, and return the Product at no charge in or out of warranty.

WARRANTY EXCLUSIONS: Damages caused by

- Accidents, falls, objects striking the SENA product,
- Operating the Product in environments that exceed SENA's temperature and humidity specifications,
- Power fluctuations, high voltage discharges,
- Improper grounding, incorrect cabling,
- Misuse, negligence by the customer or any other third party,
- Failure to install or operate the product (s) in accordance to their SENA User Manual,
- Failure caused by improper or inadequate maintenance by the customer or any other third party,
- Floods, lightning, earthquakes,
- Water spills,
- Replacement of parts due to normal wear and tear,
- Hardware has been altered in any way,
- Product that has been exposed to repair attempts by a third party without SENA's written consent,
- Hardware hosting modified SENA Software, or non-SENA Software, unless modifications have been approved by Sena.
- Battery component capacity degradation due to usage, aging, and with some chemistry, lack of maintenance.

### 13.4 SOFTWARE PRODUCT WARRANTY DETAILS

WARRANTY PERIOD: SENA warranties software Product for a period of one (1) year.

WARRANTY COVERAGE: SENA warranty will be limited to providing a software bug fix or a software patch, at a reasonable time after the user notifies SENA of software non-conformance.

### 13.5 THIRD-PARTY SOFTWARE PRODUCT WARRANTY DETAILS

The warranty policy of the third-party software is conformed to the policy of the corresponding vendor.

## 14 Regulatory Information

### 14.1 FCC

FCC Rule: Part 15 Subpart C Section 15.247

FCCID: S7AIW01

#### **FCC Compliance Statement**

This device complies with part 15 of the FCC Rules. Operation is subject to the following two conditions:

- (1) This device may not cause harmful interference, and
- (2) This device must accept any interference received,  
Including interference that may cause undesired operation

#### **Information to User**

This equipment has been tested and found to comply with limits for a Class B digital device, Pursuant to Part 15 of the FCC Rules. These limits are designed to provide reasonable protection against harmful interference in a residential installation.

This equipment generate, uses and can radiate radio frequency energy and, if not installed and used in accordance with the instructions, may cause harmful interference to radio communications.

However, there is no guarantee that interference will not occur in a particular installation. If this equipment does cause harmful interference to radio or television reception, which can be determined by turning the equipment off and on, the user is encouraged to try to correct the interference by on or more of the following measures:

- Reorient or relocate the receiving antenna.
- Increase the separation between the equipment and receiver-Connect the equipment into an outlet a circuit different form that to which the receiver is connected.
- Consult the dealer or an experienced radio/TV technician for help.

#### **RF Exposure Statement**

The equipment complies with FCC RF radiation exposure limits set forth for an uncontrolled environment. This device and its antenna must not be co-located or operation in conjunction with any other antenna or transmitter.

#### **Do not**

Any changes or modifications to the equipment not expressly approved by the party responsible for compliance could void user's authority to operate the equipment.



## 14.2 CE

CE1177(!)

We, Sena Technologies, Inc., declare that the product(s):

- ProBee-ZE20S ZigBee OEM Module

to which this declaration relates is in conformity with the following standard(s) or other normative document(s)

- EN 60950-1
- ETSI EN 301 489-1
- ETSI EN 301 489-17
- ETSI EN 300 328

Following the provisions of

- EMC DIRECTIVE 1999/5/EC

## 14.3 TELEC

Technical Regulations for Specified Radio Equipment Article 2, Section 1 (19)

Certification No:

- ProBee-ZE20SDU : 010WWBT0090
- ProBee-ZE20SDS : 010WWBT0091
- ProBee-ZE20SDC : 010WWBT0092

## 14.4 KCC

Type Registration

Certification No: KCC-CRM-SNA-IW01

Basic Model Number: ProBee-ZE20SDU

Series Model Number: ProBee-ZE20SDS, ProBee-ZE20SDC, ProBee-ZE20SSU, ProBee-ZE20SSC

## 15 RF Information

**Radio Frequency Range**

2.405~2.480GHz

**Number of Frequency Channel**

16 channels

**Transmission Method**

DSSS (Direct Sequence Spread Spectrum)

**Modulation Method**

O-QPSK (Offset Quadrature Phase Shift Keying)

**Radio Output Power**

+8dBm

**Receiving Sensitivity**

-102dBm

**Power Supply**

DC3.3V