

ZigBee OEM Module

ProBee-ZE20S-HACI

ProBee-ZE20S-HADL

ProBee-ZE20S-HAOL

User Guide

Sena Technologies, Inc.

Rev 1.8

ProBee-ZE20S-HACI, ProBee-ZE20S-HADL, ProBee-ZE20S-HAOL User Guide

Firmware version HAClv1.X

Firmware version HADLv1.X

Firmware version HAOLv1.X

Copyright

Copyright 2011 ~ 2013, Sena Technologies, Inc. All rights reserved.

Sena Technologies reserves the right to make changes and improvements to its product without providing notice.

Trademark

ProBee™ is a trademark of Sena Technologies, Inc.

Windows® is a registered trademark of Microsoft Corporation.

Ethernet® is a registered trademark of XEROX Corporation.

Notice to Users

When a system failure may cause serious consequences, protecting life and property against such consequences with a backup system or safety device is essential. The user agrees that protection against consequences resulting from system failure is the user's responsibility.

This device is not approved for life-support or medical systems.

Changes or modifications to this device not explicitly approved by Sena Technologies will void the user's authority to operate this device.

Technical Support

Sena Technologies, Inc.

210 Yangjae-dong Seocho-gu

Seoul 137-130, Korea

Tel: (+82-2) 576-7362

Fax: (+82-2) 573-7710

Email: support@sena.com

Website: <http://www.sena.com>

Revision	Date	Name	Description
V1.6	2013-02-26	Uin Burn	Initial Writing.
V1.8	2013-08-28	Uin Burn	Removed AT+KEYS command. Added AT+SOURCELA command. Modification for Factory_reset button information. Added information about Endpoint.

Contents

1	INTRODUCTION.....	10
1.1	About This Document.....	10
1.2	ZE20S Overview.....	10
1.3	ZigBee Home Automation Profile	11
1.4	Home Automation Definitions	11
1.4.1	<i>Cluster</i>	11
1.4.2	<i>Attribute</i>	11
1.4.3	<i>Cluster identifier</i>	11
1.4.4	<i>Endpoint</i>	12
1.4.5	<i>Client</i>	12
1.4.6	<i>Server</i>	12
2	GETTING STARTED.....	13
2.1	Hardware Installation.....	13
2.1.1	<i>Development Board Layout</i>	13
2.1.2	<i>Antenna Installation</i>	14
2.1.3	<i>Module Installation on the Development Board</i>	14
2.1.4	<i>Serial/USB Cable Installation</i>	15
2.1.5	<i>Powering Development Board</i>	16
2.1.6	<i>USB Driver Installation</i>	16
2.2	Using Terminal Software for AT Commands.....	17
2.3	Using ProBee Manager for Configuration.....	18
2.3.1	<i>Serial Port Open</i>	18
2.3.2	<i>Configuration</i>	19
2.3.3	<i>Firmware Update</i>	21
3	ZIGBEE NETWORK CONFIGURATION.....	23
3.1	Setting up ZE20S as a Coordinator	23
3.1.1	<i>Node Type Selection for Coordinator</i>	24
3.1.2	<i>Channel Mask Configuration for Coordinator</i>	24
3.1.3	<i>PAN ID Configuration for Coordinator</i>	25
3.1.4	<i>Permit Joining</i>	25
3.2	Setting up ZE20S as a Router.....	26
3.2.1	<i>Node Type Selection for Router</i>	26
3.2.2	<i>Channel Mask Configuration for Router</i>	27
3.2.3	<i>PAN ID Configuration for Router</i>	27
3.2.4	<i>Permit Joining</i>	27

3.3	Setting up ZE20S as an End-Device	28
3.4	Setting up ZE20S as a Sleepy End-Device	29
3.5	ZigBee Security	30
3.5.1	Security Level.....	31
3.5.2	Link Key.....	31
3.5.3	Network Key.....	31
3.5.4	Update Key.....	31
3.6	Frequency Agility	31
4	DIGITAL AND ANALOG I/O.....	33
4.1	GPIO (General Purpose Inputs and Outputs) Configuration.....	33
4.2	HA GPIO.....	34
5	WORKING WITH DEVELOPMENT KIT	36
5.1	Development Kit Contents	36
5.2	Development Board Features.....	36
5.3	Development Board Hardware Descriptions	37
5.3.1	Power.....	37
5.3.2	RS232 Port.....	37
5.3.3	USB Port.....	38
5.3.4	ZE20S GPIO Interface.....	38
5.3.5	LEDs (CR12-19).....	39
5.3.6	Button Switches (SW10-17).....	39
5.3.7	Variable Resistors (VR1, VR2).....	39
5.3.8	Temperature Sensor.....	39
5.3.9	Light Sensor	39
5.3.10	Terminal Block.....	40
5.4	Configuration Example: 1 Coordinator and 2 End-Devices.....	40
5.4.1	ProBeeHACI Coordinator Configuration	41
5.4.2	ProBeeHADL End-device Configuration	41
5.4.3	ProBeeHAOL End-device Configuration	42
5.4.4	Turning on/off the ProBeeHADL End Device LEDs from ProBeeHACI Coordinator.....	42
5.4.5	Turning on/off the ProBeeHAOL End-device LEDs from ProBeeHACI Coordinator.....	43
6	HA(HOME AUTOMATION) PROFILE DESCRIPTIONS	44
6.1	Device Descriptions.....	44
6.2	ZigBee Cluster Library (ZCL).....	45
6.3	Cluster Binding	45
6.4	ProBee HA Profiles Description.....	47
6.4.1	ProBeeHACI (Combined Interface)	47

6.4.2	<i>ProBeeHADL (Door Lock)</i>	49
6.4.3	<i>ProBeeHAOL (Color Dimmable Light)</i>	52
7	AT COMMAND REFERENCE	56
7.1	Command Line Format	56
7.2	Standard AT Commands	56
7.2.1	<i>AT</i>	56
7.2.2	<i>ATE</i>	56
7.2.3	<i>ATR</i>	56
7.2.4	<i>ATS</i>	56
7.2.5	<i>ATZ</i>	57
7.2.6	<i>AT&F</i>	57
7.3	Node Specific Information.....	57
7.3.1	<i>AT+LONGADDR or AT+LA</i>	57
7.3.2	<i>AT+SHORTADDR or AT+SA</i>	57
7.3.3	<i>AT+ADDRDISCOVERY or AT+AD</i>	57
7.3.4	<i>AT+OPCH or AT+OC</i>	58
7.3.5	<i>AT+OPPANID or AT+OI</i>	58
7.3.6	<i>AT+OPEPID or AT+OE</i>	58
7.3.7	<i>AT+VERSION or AT+VR</i>	58
7.3.8	<i>AT+PRODUCTNAME or AT+PN</i>	58
7.4	Network Specific Parameters	59
7.4.1	<i>AT+CHMASK or AT+CM</i>	59
7.4.2	<i>AT+PANID or AT+PI</i>	59
7.4.3	<i>AT+EPID or AT+EI</i>	59
7.4.4	<i>AT+GROUPEPID or AT+GI</i>	59
7.4.5	<i>AT+POWER or AT+PW</i>	60
7.4.6	<i>AT+STACK or AT+ZS</i>	60
7.4.7	<i>AT+NODENAME or AT+NN</i>	60
7.5	Network Formation and Join.....	60
7.5.1	<i>AT+ASCAN or AT+AS</i>	60
7.5.2	<i>AT+ESCAN or AT+ES</i>	61
7.5.3	<i>AT+DSCAN or AT+DS</i>	61
7.5.4	<i>AT+RSSI or AT+RS</i>	61
7.5.5	<i>AT+NODETYPE or AT+NT</i>	62
7.5.6	<i>AT+PERMIT or AT+PJ</i>	62
7.5.7	<i>AT+LEAVE or AT+LV</i>	62
7.6	End-device	62
7.6.1	<i>AT+SLEEP or AT+SM</i>	62
7.6.2	<i>AT+PARENTLA or AT+PL</i>	62

7.6.3	<i>AT+PARENTSA or AT+PS</i>	63
7.6.4	<i>AT+CHILDTABLE or AT+CT</i>	63
7.7	Data Transmission and Reception	63
7.7.1	<i>AT+MAXPAYLOAD or AT+MP</i>	63
7.8	Security	63
7.8.1	<i>AT+SECURITY or AT+SE</i>	63
7.8.2	<i>AT+LINKKEY or AT+LK</i>	63
7.8.3	<i>AT+NWKEY or AT+NK</i>	64
7.8.4	<i>AT+UPDATEKEY or AT+UK</i>	64
7.9	UART	64
7.9.1	<i>AT+BAUDRATE or AT+UB</i>	64
7.9.2	<i>AT+DATABIT or AT+UD</i>	64
7.9.3	<i>AT+PARITY or AT+UP</i>	64
7.9.4	<i>AT+STOPBIT or AT+US</i>	65
7.9.5	<i>AT+FLOWCTRL or AT+UF</i>	65
7.10	GPIO.....	65
7.10.1	<i>AT+GPIO or AT+IO</i>	65
7.10.2	<i>AT+DIO</i>	65
7.10.3	<i>AT+AI</i>	66
7.10.4	<i>AT+SOURCELA or AT+SL</i>	66
7.11	Firmware Upload and Help.....	66
7.11.1	<i>AT+BOOTLOAD or AT+BL</i>	66
7.11.2	<i>AT+HELP or AT+HP</i>	67
7.12	Home Automation Commands.....	67
7.12.1	<i>AT+ATTR or AT+AR</i>	67
7.12.2	<i>AT+INFO or AT+IF</i>	67
7.12.3	<i>AT+DEST or AT+DE</i>	67
7.12.4	<i>AT+SREAD or AT+SR</i>	67
7.12.5	<i>AT+CREAD or AT+CR</i>	68
7.12.6	<i>AT+SWRITE or AT+SW</i>	68
7.12.7	<i>AT+CWRITE or AT+CW</i>	68
7.12.8	<i>AT+SCMD or AT+SC</i>	68
7.12.9	<i>AT+CCMD or AT+CC</i>	68
7.12.10	<i>AT+FACTORYRESET or AT+FR</i>	68
7.12.11	<i>AT+IDENTIFY or AT+II</i>	69
7.12.12	<i>AT+IDENQUERY or AT+IQ</i>	69
7.13	ProBeeHACI (Combined Interface) Profile Commands.....	69
7.13.1	<i>AT+LOCK or AT+LK</i>	69
7.13.2	<i>AT+UNLOCK or AT+UL</i>	69
7.13.3	<i>AT+ON</i>	69

7.13.4	<i>AT+OFF or AT+OF</i>	69
7.13.5	<i>AT+TOGGLE or AT+TG</i>	70
7.13.6	<i>AT+MVTOLV or AT+ML</i>	70
7.14	ProBeeHADL (Door Lock) Profile Commands	70
7.14.1	<i>AT+RLOCK or AT+RLK</i>	70
7.14.2	<i>AT+RUNLOCK or AT+RUK</i>	70
8	S-REGISTERS	71
8.1	Display Options.....	71
8.1.1	<i>S11</i>	71
8.1.2	<i>S12</i>	71
8.1.3	<i>S13</i>	72
8.1.4	<i>S14</i>	72
8.2	Network Settings	72
8.2.1	<i>S22</i>	72
8.2.2	<i>S23</i>	72
8.3	GPIO.....	73
8.3.1	<i>S41</i>	73
8.3.2	<i>S42</i>	73
8.3.3	<i>S43</i>	73
8.3.4	<i>S44</i>	73
8.3.5	<i>S45</i>	74
8.4	End-Device.....	74
8.4.1	<i>S51</i>	74
8.4.2	<i>S52</i>	74
8.4.3	<i>S53</i>	75
8.4.4	<i>S54</i>	75
8.4.5	<i>S55</i>	75
8.4.6	<i>S56</i>	75
8.5	Frequency Agility	76
8.5.1	<i>S71</i>	76
9	HA COMMAND EXAMPLE	77
9.1	Cluster Command for Binding (ProBeeHACI - ProBeeHADL).....	77
9.2	Cluster Command for Binding (ProBeeHACI - ProBeeHAOL).....	78
9.3	Showing Attribute Information.....	79
9.4	Reading Attribute.....	80
9.5	Writing Attribute	81
9.6	Sending HA Command.....	82
9.7	Receive HA Command.....	83

9.8	Testing HA GPIO	83
10	PIN ASSIGNMENTS	85
11	CONNECTIONS.....	87
11.1	Serial Port Pin Outs	87
11.2	Serial Wiring Diagram	88
11.2.1	<i>To Host with DTE Interface</i>	<i>88</i>
11.2.2	<i>To Host with DCE Interface.....</i>	<i>88</i>
12	MECHANICAL DRAWINGS.....	89
13	WARRANTY.....	91
13.1	GENERAL WARRANTY POLICY.....	91
13.2	LIMITATION OF LIABILITY.....	91
13.3	HARDWARE PRODUCT WARRANTY DETAILS	92
13.4	SOFTWARE PRODUCT WARRANTY DETAILS.....	92
13.5	THIRD-PARTY SOFTWARE PRODUCT WARRANTY DETAILS.....	92
14	REGULATORY INFORMATION.....	93
14.1	FCC	93
14.2	CE.....	94
14.3	TELEC.....	94
14.4	KCC.....	94
15	RF INFORMATION.....	95

1 Introduction

1.1 About This Document

This document provides an introduction on configuration and operation of the ZigBee Home Automation(hereinafter referred to as the “HA”) Profile device such as the ProBee-ZE20S-HACI (Home Automation Combined Interface, hereinafter referred to as the “ProBeeHACI”), the ProBee-ZE20S-HADL(Home Automation Door Lock, hereinafter referred to as the “ProBeeHADL”) and the ProBee-ZE20S-HAOL(Home Automation On/Off Light, hereinafter referred to as the “ProBeeHAOL”) which are based on the ProBee-ZE20S(hereinafter referred to as the “ZE20S”) ZigBee OEM module. This document assumes the user is using the ZE20S starter kit for evaluation hence the pictures and configuration examples shown in this document are all based on the ZE20S starter kit.

This document does not provide full detail of the hardware specifications. Please refer to the ProBee-ZE20S data sheet for further references on the hardware design.

1.2 ZE20S Overview

The ProBee-ZE20S is an all-in-one ZigBee OEM module with integrated ZigBee core and radio/antenna circuits together with high level software library. Using the ZE20S, OEM manufacturers can easily and cost-effectively integrate ZigBee functionality into target products in timely manner.

The ZE20S OEM module is designed to meet specific requirements of low cost and low power wireless applications such as Home Automation, Smart Energy, Health care, Building Automation and Telecom Services by adopting the ZigBee technology. The ZE20S is based on the Ember EM357 ZigBee core and certified ZigBee Alliance based on ZigBee 2007 and ZigBee Pro stack.

Despite of its low cost and low power consumptions, the ZE20S provides high performance and robust data transfer capability for wide range of applications. The ZE20S can transfer data at up to 250 kbps and reach up to 300 m (0.19 miles) outdoor line-of-sight.

Key Features

- Integrated 2.4GHz, IEEE 802.15.4-2003 compliant transceiver
- ZigBee 2007 / ZigBee Pro stack
- ZigBee core: Ember EM357
- Transmit Power: +8dBm (Boost mode)
- Receiver Sensitivity: -102dBm @1% BER (Boost mode)
- Supply Voltage: 2.1~3.6 VDC
- TX Current: 45mA @3.3V (max.)
- RX Current: 31mA @3.3V (max.)
- Sleep Current: $\leq 1\mu\text{A}$

- Working Distance: 300 m (0.19 miles) @ 3.3V, +5dBi Dipole Antenna
- Various Antenna/Connector Options: Dipole 1/3/5dBi, U.FL, RPSMA, Chip
- UART Signals Support: UART_TXD/RXD, RTS/CTS, DTR/DSR
- 6 Analog Inputs
- 17 Digital Inputs/Outputs
- RoHS Compliant

Applications

- Advanced Metering Infrastructure
- Home Area Networks (HAN)
- Neighborhood Area Networks (NAN)
- Home Automation
- Advanced lighting, entertainment and climate control systems
- Service-based monitoring, security and awareness systems
- Commercial Building Automation
- Climate & lighting control systems
- Industrial and Domestic Applications

1.3 ZigBee Home Automation Profile

ZigBee Home Automation Profile defines device descriptions and standard practices for applications commonly found in a residential or light commercial environment. Installation scenarios range from a single room to an entire home. The key applications included in this profile are lighting, HVAC, window shades and security.

ZigBee Home Automation Profile provides standard interfaces and device definitions to allow interoperability among ZigBee Home Automation devices produced by various manufacturers.

1.4 Home Automation Definitions

1.4.1 Cluster

Cluster is a container for one or more attributes and/or messages in a command structure. And Cluster is a related collection of attributes and commands, which together define a communications interface between two devices. The devices implement server and client sides of the interface respectively.

1.4.2 Attribute

Attribute is a data entity which represents a physical quantity or state. This data is communicated to other devices using commands.

1.4.3 Cluster identifier

Cluster identifier is a reference to the unique enumeration of clusters within a specific application profile. The cluster identifier is a 16-bit number unique within the scope of the application profile and identifies a specific cluster. Cluster identifiers are designated as inputs or outputs in the simple descriptor for use in

creating a binding table.

1.4.4 Endpoint

Endpoint is a particular component within a unit. Each ZigBee device may support up to 240 such components. ZE20S has just 1 endpoint.

1.4.5 Client

Client is a cluster interface which is listed in the output cluster list of the simple descriptor on an endpoint. Typically this interface sends commands that manipulate the attributes on the corresponding server cluster.

1.4.6 Server

Server is a cluster interface which is listed in the input cluster list of the simple descriptor on an endpoint. Typically this interface supports all or most of the attributes of the cluster.

2 Getting Started

Creating a ZigBee network using the ZE20S modules consists of the following steps:

- Install the ZE20S module on the development board
- Create a ZigBee network by configuring a ZE20S module as the coordinator
- Configure ZE20S modules as routers. This step is optional since the coordinator works as a router too.
- Configure ZE20S modules as end-devices
- Transmit data between ZE20S devices

This chapter describes how to install the ZE20S modules on to the development boards and how to use terminal software programs to access the ZE20S modules using AT commands for configurations and operations. The rest of the steps including ZigBee network creation, coordinator/router/end-device configurations and data transmissions are described in the following chapters. The more detailed information on the starter kit and the configuration examples are also provided in the later chapter.

2.1 Hardware Installation

2.1.1 Development Board Layout

Figure 2-1 shows the layout of the development board. The development board provides the interface between the ZE20S and the external serial port or USB port together with input/output terminals for convenient tests.

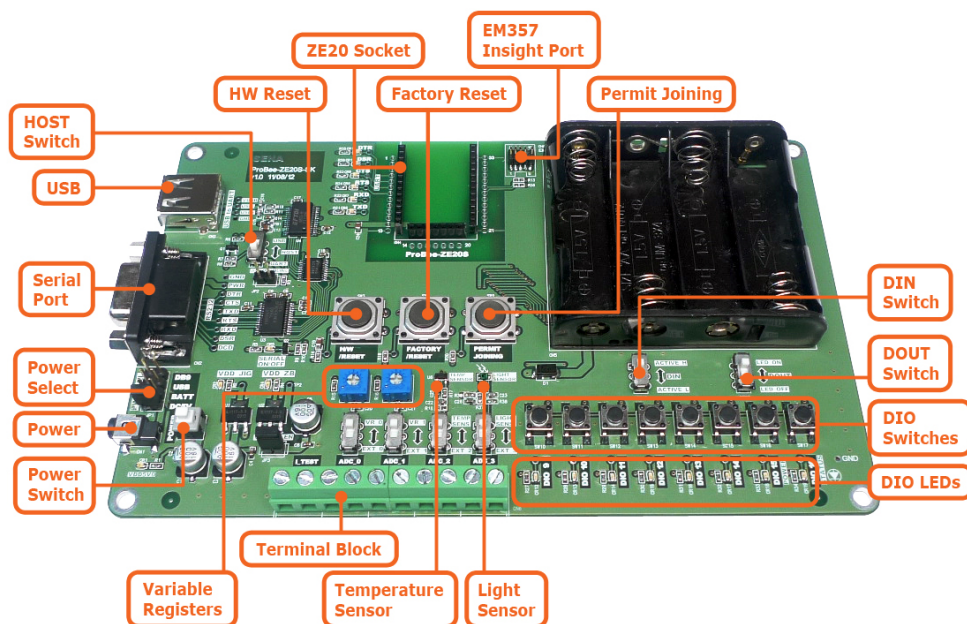

Figure 2-1 Development Board Layout

2.1.2 Antenna Installation

The ZE20S starter kit includes the several antennas for evaluation purposes. You can try different antennas for testing purpose and select the appropriate antenna for the actual applications. Figure 2-2 shows how to install the RP-SMA dipole antenna to the ZE20S module.



Figure 2-2 RP-SMA Dipole Antenna Installation

2.1.3 Module Installation on the Development Board

Once the antenna is installed on the ZE20S module, the ZE20S module can be installed on the development board.

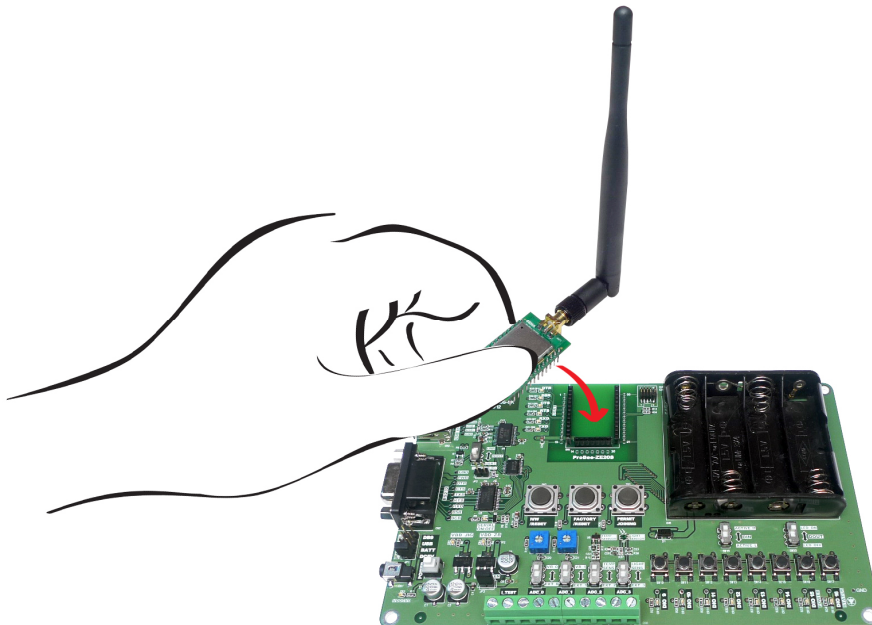

Figure 2-3 ZE20S Installation on the Development Board

2.1.4 Serial/USB Cable Installation

After the ZE20S is securely installed on the development board, please connect the included serial cable between the development board and your computer so AT commands can be sent from the computer to the ZE20S module. The serial port of the development board is DB9 female as a DTE terminal, and the serial cable included is a cross-over cable for DTE-DTE connection. To use the serial port, the HOST (SW2) switch should be set to UART.

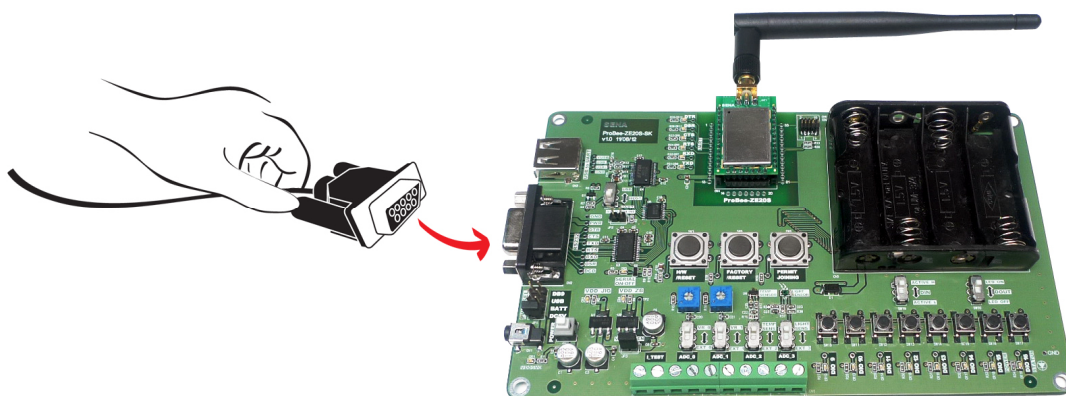

Figure 2-4 Serial Cable Installation

In case the serial port is not available for the computer, you can use the USB port of the development board instead. In this case, the internal USB-RS232 converter of the development board will convert the USB signal to the RS232 signal and vice versa. To use the USB port, the HOST (SW2) switch should be set to USB and the software driver for the USB in the CD should be installed on the computer. For the USB driver installation, please refer to the section 2.1.6.

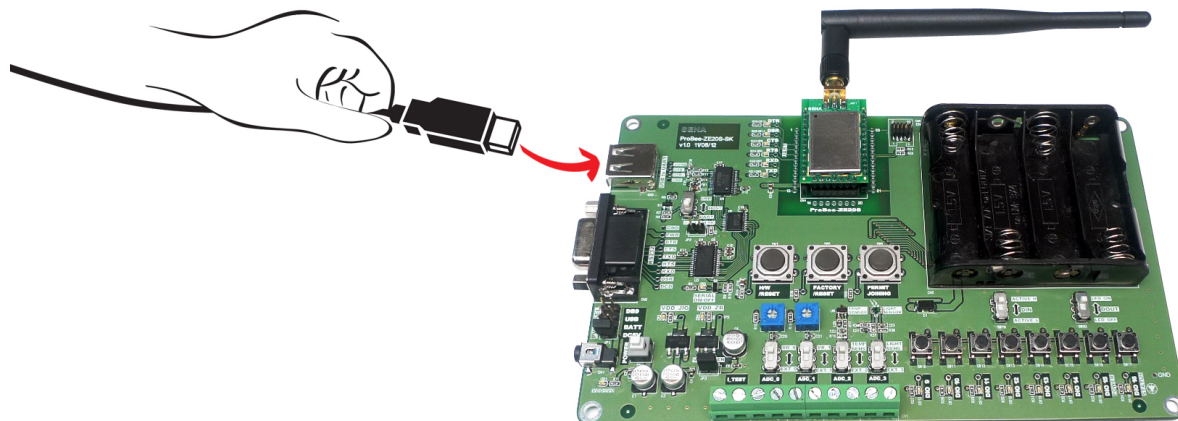

Figure 2-5 USB Cable Installation

2.1.5 Powering Development Board

Once all the installations are completed, please plug in the power connector using the included DC power adapter. The RS_PWR, USB_PWR and BATT_EN jumpers should be all OPEN to use the DC power adapter. Alternatively, the development board can be powered using batteries, or from the USB port or through the RS232 port pin 9. In these cases, the power source jumpers should be set accordingly. For details about the power source jumper settings, please refer to the section **5.3.1 Power**.

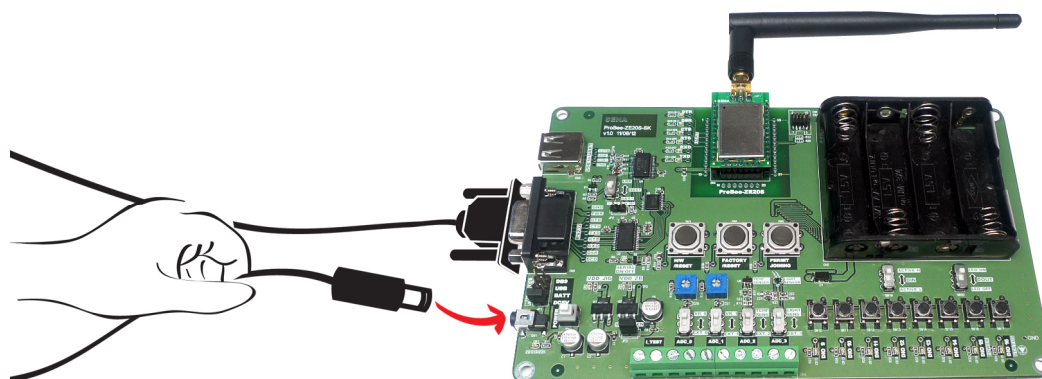

Figure 2-6 Plugging DC Power Adapter

2.1.6 USB Driver Installation

In case the USB interface is used for the communication between the development board and the computer, the corresponding software driver needs to be installed on the computer. Windows XP and later versions already include the USB driver. When Windows asks for the location of the USB driver, you can select the option to “install the software automatically” as shown in Figure 2-7. You can also choose to install the driver from the CD included if the driver is not installed correctly for some reason.

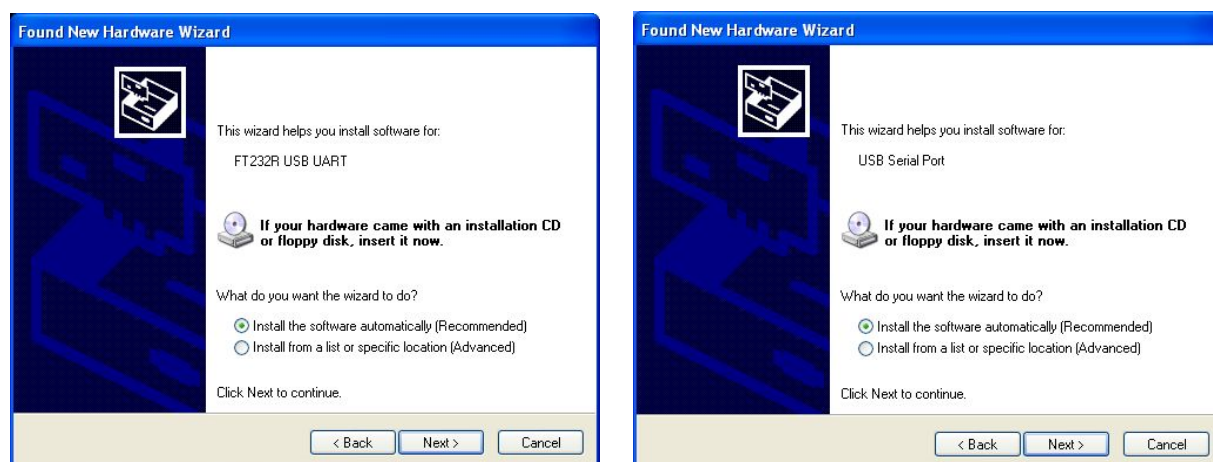

Figure 2-7 USB Driver Installation

2.2 Using Terminal Software for AT Commands

Once the hardware installation is complete, the ZE20S unit is ready to communicate with the computer using the AT commands using a terminal emulation software. You can use any kind of terminal emulation software. This document assumes HyperTerminal is used. If you are using Windows Vista or 7, HyperTerminal is no longer included in the Windows so you need to download HyperTerminal from the Internet. For more details on HyperTerminal, please refer to Microsoft web page.

Once the HyperTerminal is installed, launch HyperTerminal and select the serial port that is connected to the ZE20S development board and enter the serial settings to use. The default serial settings of the ZE20S are **9600 bps, 8 data bit, none parity, 1 stop bit, none flow control**.

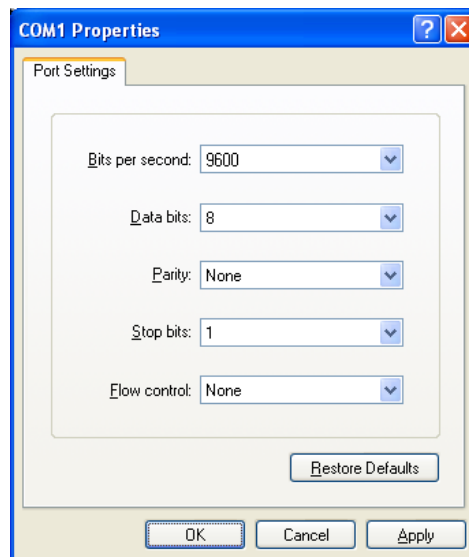

Figure 2-8 HyperTerminal Serial Settings

To display the AT commands that are being typed, you need to enable the local echo option on the HyperTerminal. To enable this option, Go to File->Properties->Settings->ASCII setup and select the "Echo typed characters locally" option. To verify the connection, type AT and press the Enter key. If the AT command is accepted by the ZE20S, OK string will be displayed on the screen.

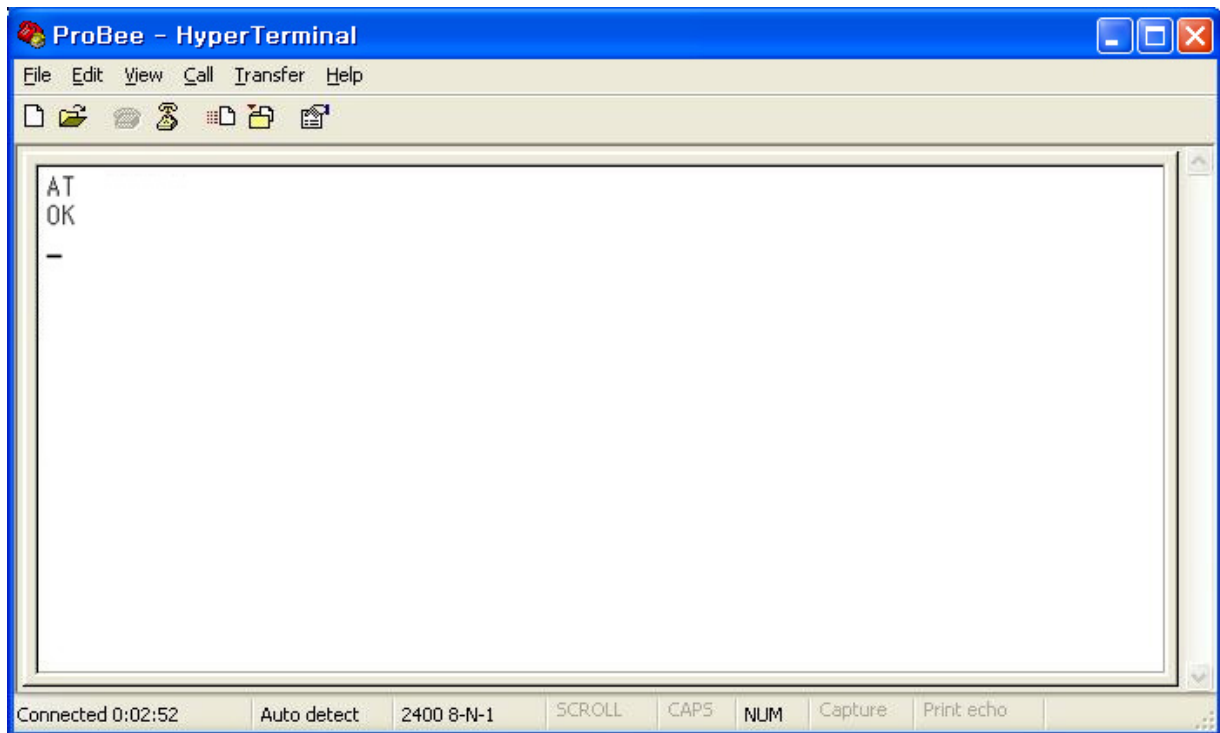

Figure 2-9 Testing AT Command on HyperTerminal

2.3 Using ProBee Manager for Configuration

It is possible to set or get the configurations of the ZE20S using ProBee Manager. This PC utility helps that a user can configure several setting values of local node and remote node easily without a terminal program. It is possible to export current configuration and import it to other nodes. It is also possible to restore to factory default configuration.

It provides users with functions to upgrade firmware of not only local node but also remote node.

2.3.1 Serial Port Open

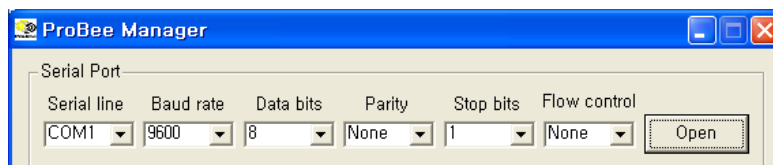

Figure 2-10 ProBee Manager Serial Port Open

To connect to local node through serial port, please follow the steps as below:

- Set 'Serial Port' properties corresponding to the UART configuration of local node.
- Click 'Open' button.

ProBee manager displays the main window like Figure 2-11 after connecting to local node.

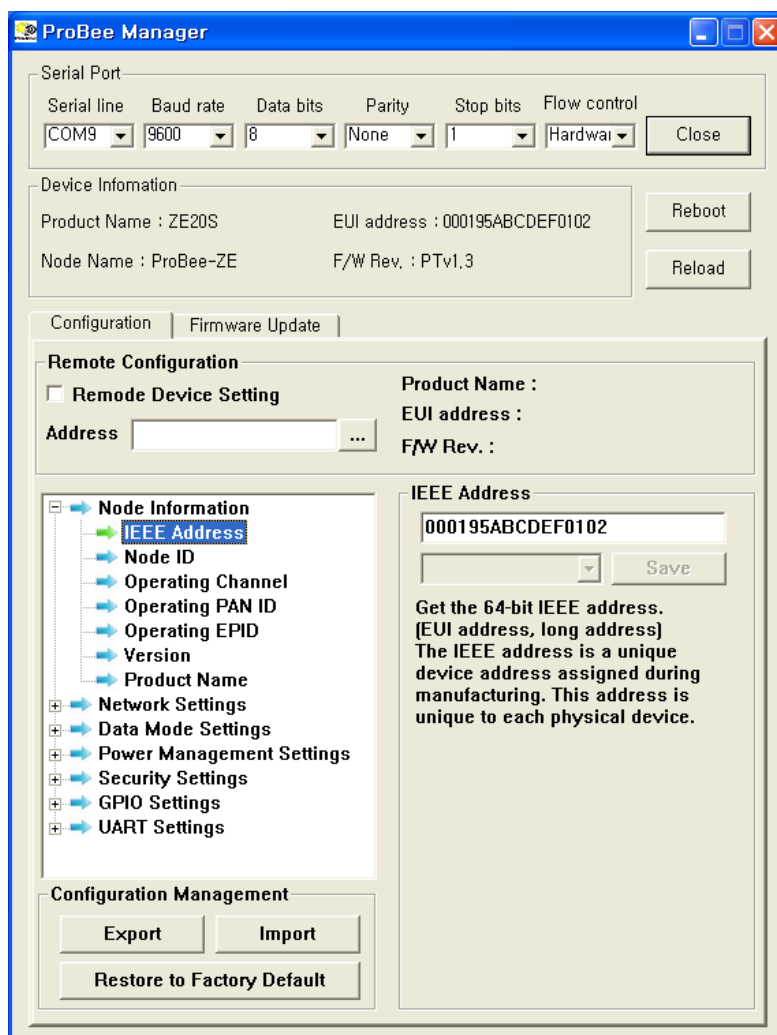

Figure 2-11 ProBee Manager Main Window

Clicking 'Reboot' button reboots the local node. Users can reload and refresh the recent configuration of the local node at ProBee manager by clicking 'Reload' button. 'Configuration' tab and 'Firmware Update' tab can help move to the 'Configuration' screen and the 'Firmware Update' screen.

2.3.2 Configuration

The Configuration Pane appears when the 'Configuration' tab is selected.

To change configuration, users need to find and modify the property and then apply changes. The properties are categorized according to the function. Selecting a category unfolds or folds the property list. The name, the current value and the description of the property are shown at the right of the configuration pane by selecting a property in the property list. It is possible to edit and save the current value of editable property. Whenever property is modified, it is necessary to save the change by clicking the 'Save' button

in order not lose it moving to other properties. To apply changes, please reboot the device by clicking 'Reboot' button. The 'Save' button is disabled for read-only property.

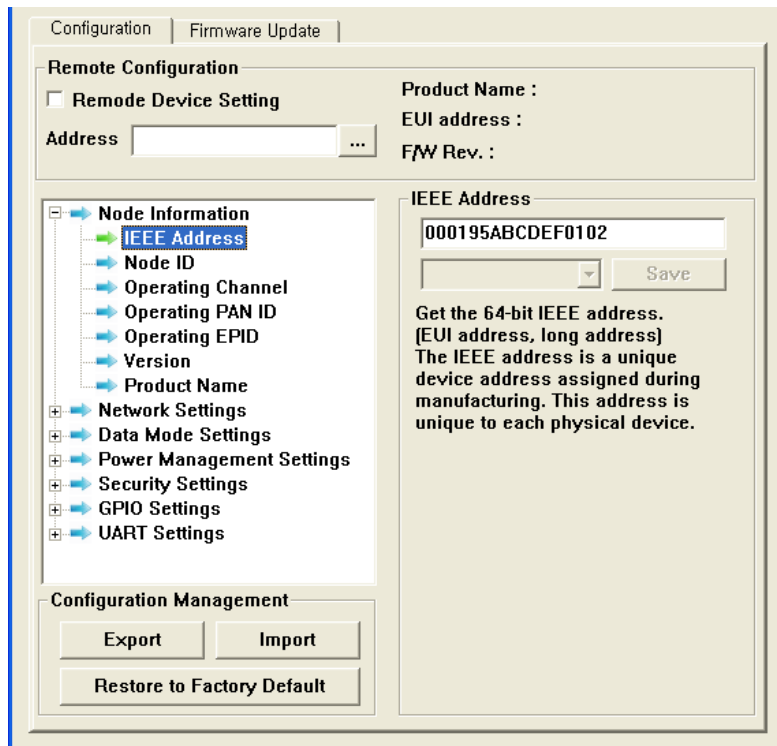

Figure 2-12 ProBee Manager Configuration Pane

In Figure 2-12, the 'Node Information' category is selected and the 'IEEE Address' property is selected, so its description is displayed. The 'Save' button is disabled because the 'IEEE Address' property is read-only.

The configurations of the remote nodes joining the network where the local node belongs can be modified, too. Because a sleepy end-device often enters sleep mode, to remote configuration from a sleepy end-device may not work.

To connect to local node through serial port, please follow the steps as below:

- Click the '...' button at 'Remote Configuration' section.
- Scan the remote nodes joining the network and select the remote node to configure, that results in displaying the remote node in the 'Address' edit box.
- Check the 'Remote Device Setting' check box and the caption of the 'Restore to Factory Default' button at the 'Configuration Management' section becomes 'Reboot' that makes the remote node reboot and configuration of the selected node is displayed.
- Select and modify the property.
- Click the 'Save' button.

- Click the 'Reboot' button whose caption used to be 'Restore to Factory Default' to apply changes.

To export the configuration, please follow the steps as below:

- Click the 'Export' button at the 'Configuration Management' section and the 'Save As' dialog pops up.
- Select the path and enter the file name to store the configuration at.
- Click the 'Save' button and the configuration is exported to the designated file.

Exported file can be used at other devices by importing them. The configuration of remote node can be exported and imported by checking the 'Remote Device Setting' check box.

Users can reset to factory default by clicking the 'Restore to Factory Default' at the 'Configuration Management' section.

2.3.3 Firmware Update

Type	IEEE Address	Version	ModelType	NodeName	Progress

Figure 2-13 ProBee Manager Firmware Update Pane

The Firmware Update Pane appears when the 'Firmware Update' tab is selected. The 'Message' section displays informative message about the progress of updating firmware.

To update firmware at local node, please follow the steps as below:

- Select a firmware file to update at the 'Firmware Update' section. The 'Choose file in local PC' button pops up the dialog where users can select the firmware file at local PC and the 'Download from web server' button helps users download the firmware from web server.
- Click the 'Update' button at the 'Device Update' section to update the local node. The progress rate is expressed at the 'Local Device Update' section and informative messages are shown at 'Message' section.

ProBee Manager also supports to update the firmware of remote nodes which join the network where local node is. Because a sleepy end-device often enters sleep mode, to update remote node from a sleepy end-device may not work.

To update firmware at remote node, please follow the steps as below:

- Select a firmware file.
- Click the 'Search' button, that scans the remote nodes joining the network where local node belongs.
- Select the remote nodes to update in the remote nodes list.
- Click the 'Update' button at the 'Remote Device Update' section.

3 ZigBee Network Configuration

A ZigBee Network consists of a coordinator, routers and end-devices. A minimal ZigBee network consists of one coordinator and multiple end-devices which directly connect to the coordinator. For larger ZigBee networks, routers are required to provide redundant routings to form mesh networks.

- **ZigBee Coordinator:** The coordinator forms the root of the network tree and might bridge to other networks. There is exactly one ZigBee coordinator in each network since the coordinator starts the ZigBee network itself. It also stores information about the network, including acting as the Trust Center & repository for security keys.
- **ZigBee Router:** The routers are able to route messages between other devices. Since the coordinator provides the routing functionality too, the routers are optional to form a ZigBee network.
- **ZigBee End-Device:** The end-device contains just enough functionality to talk to the parent node which is either the coordinator or a router. It cannot relay data from other devices.
- **ZigBee Sleepy End-Device:** The sleepy end-device is the same with normal end-device except it can stay in the sleep mode much longer. This relationship allows the end-device to sleep significant amount of the time and achieve the long battery life.

The ZE20S can be configured to work either as a coordinator, a router, an end-device or a sleepy end-device. Once the operation mode of the ZE20S is selected, corresponding parameters need to be set up appropriately. This chapter explains how to configure the ZE20S operation mode and other parameters related to the ZigBee network itself.

Table 3-1 ZigBee Node Types

Node Type	Recommendation when to use ZE20S
Coordinator	It should be selected when it is first time to establish the network.
Router	It is recommended when there is a network already and it needs to be expanded. A router is suitable for fast and stable data transmissions and receptions.
End-Device	It is recommended when it doesn't need to expand the network anymore and there are enough nodes as parents. An end-device consumes less power than a router.
Sleepy End-Device	It is recommended when the data transmissions occur rarely and in very small quantities. A sleepy end-device can lose data if sleep duration is too long, but it is possible to consume extremely low power as low as 2uA.

3.1 Setting up ZE20S as a Coordinator

A coordinator relays messages and can act as a parent to other nodes. Every personal area network (PAN) must be started by a node acting as the coordinator. In general, this device is always powered on.

To set up the ZE20S to work as the coordinator, please follow the steps as below

- Configure the ZE20S node type as the coordinator
- Optionally, select the channel mask. Otherwise, the ZE20S will use the default channel mask.
- Optionally, set up the PAN ID and/or the extended PAN ID. Otherwise, the ZE20S will generate the PAN ID and/or the extended PAN ID automatically.
- Permit joining when other router or end-device tries to join the ZigBee network.

3.1.1 Node Type Selection for Coordinator

The ZE20S module can be configured as a ZigBee coordinator by the AT command as below:

AT+NODETYPE=n or AT+NT=n

, where n is 0 = none, 1 = coordinator, 2 = router, 3 = end-device, 4 = sleepy end-device

After the operation mode is selected, ATZ command should be performed to reset the unit to have the change applied.

Example)

```
AT+NODETYPE=1<CR>      # Set node type as the coordinator
OK<CR>                 # Response
ATZ<CR>                # Apply the change
OK<CR>                 # Response
```

3.1.2 Channel Mask Configuration for Coordinator

When the ZigBee coordinator starts, it scans predefined frequency channels to find the best frequency channel to use without causing interference with other wireless devices. The user is able to specify the channels to use with the AT command as below:

AT+CHMASK=n or AT+CM=n

, where n = channel mask to use. Default = 0x07FFF800

This value has a 32-bit hexadecimal unsigned integer. Each bit represents whether a channel will be used or not. For example, to use a channel between 12 and 15, the 12, 13, 14 and 15 bits of the channel mask should be 1 and all other bits should be 0. The default setting is 0x7FFF800 which means that all the channels from 11 to 26 can be used. The ZE20S supports only the channels between 11 and 26, so 0~10 bits and 27~31 bits should be 0. Table 3-2 shows the bit mask for each channel.

Table 3-2 Channel Bitmask

Channel	11	12	13	14	15	16	17	18
Bit mask	00000800	00001000	00002000	00004000	00008000	00010000	00020000	00040000
Channel	19	20	21	22	23	24	25	26
Bit mask	00080000	00100000	00200000	00400000	00800000	01000000	02000000	04000000

3.1.3 PAN ID Configuration for Coordinator

Every ZigBee network should be assigned a PAN ID to identify the network. If the PAN ID is 0000, the ZE20S will generate a random 16-bit PAN ID to start the ZigBee network. Otherwise, the user can enter the PAN ID using the AT command as below:

AT+PANID=xxxx or AT+PI=xxxx

, where xxxx is PAN ID to use. For example, 12AB. Default setting is 0000

When choosing a PAN ID, the user needs to make sure that there is no ZigBee network using the same PAN ID. If the PAN ID is already used by another ZigBee network, the PAN ID is unavailable and the user should choose a new PAN ID. In order to avoid this, PAN ID auto-generation is strongly recommended.

The user can also assign the 64-bit extended PAN ID to the ZE20S using the AT command below. If the extended PAN ID is 0000000000000000, the ZE20S uses its IEEE address as the extended PAN ID. The extended PAN ID cannot be shared with other ZigBee networks, either.

AT+EPID=xxx...xxx or AT+EI= xxx...xxx

, where xxx...xxx is EPID to use. For example, 0123456789ABCDEF. Default setting is 000...000.

3.1.4 Permit Joining

When a router or an end-device tries to join the ZigBee network, there should be at least one coordinator or router which is permitting joining. If there is no router in the ZigBee network yet, the coordinator should permit joining. The ZE20S provides three ways to permit joining are as follows:

- Permanently permitting by configuration
- Transiently permitting by AT command
- Transiently permitting by digital input signal

If joining is permanently permitted, any device can join anytime. Since this will allow even an unidentified device to join the network anytime, this mode should be selected with extra caution. The AT command to permit joining permanently is as follows:

AT+PERMIT=255 or AT+PJ=255

The user can permit joining for a moment at need. The AT command to permit joining is

`AT+PERMIT=n or AT+PJ=n`

, where *n* is the duration to permit in seconds ranging 1~254 seconds.

The user can also configure the ZE20S to permit joining when the digital input GPIO0 is active. The AT command to enable this functionality is as follows:

`AT+GPIO0=5 or AT+IO0=5`

When the ZE20S detects falling edge of the GPIO0, the ZE20S permits joining for the duration that is configured in S-register 22 (S22). The AT command to change the duration is as follows:

`ATS22=n`

, where *n* is the duration to permit in seconds ranging 1~254 seconds. Default is 255.

S22 value determines the time that the device will allow other devices to join to it. If set to 255, the device will always permit other nodes joining. If the user reboots the coordinator (or a router), the device allows other nodes to join the network for the period defined by S-register 22.

Note: When a device that has joined a network reboots, the device is able to join the network regardless of permitting. But, after the device has joined other network, rejoining the previous network should be permitted by the coordinator or a router.

3.2 Setting up ZE20S as a Router

A router is a full-function routing device that relays messages and can act as a parent to other nodes. These devices must be always powered on.

To configure the ZE20S as a ZigBee router, please follow the steps below.

- Configure the ZE20S node type as a router.
- Optionally, select the channel mask. Otherwise, the ZE20S will use the default channel mask.
- Optionally, set up the PAN ID and/or the extended PAN ID. Otherwise, the ZE20S will scan and join the ZigBee network found automatically.
- Permit joining when other router or end-device tries to join the ZigBee network.

3.2.1 Node Type Selection for Router

The ZE20S module can be configured as a ZigBee router by the AT command as below:

`AT+NODETYPE=n or AT+NT=n`

, where *n* is 0 = none, 1 = coordinator, 2 = router, 3 = end-device, 4 = sleepy end-device

After the operation mode is selected, ATZ command should be performed to reset the unit to have the change applied.

Example)

```
AT+NODETYPE=2<CR>      # Select router mode
OK<CR>                  # Response
ATZ<CR>                 # Apply the change
OK<CR>                  # Response
```

3.2.2 Channel Mask Configuration for Router

When the ZE20S as a ZigBee router or a ZigBee end-device tries to join, it scans all the channels configured by channel mask to find the ZigBee network to join. The channel mask of router or end-device should include the channel on which the coordinator is operating. On the assumption that the coordinator of the network to join is operating on channel 12, the router or end-device trying to join should have a channel mask of which 12th bit is 1.

3.2.3 PAN ID Configuration for Router

The PAN ID of a ZigBee router or a ZigBee end-device should be the same with the PAN ID of the ZigBee coordinator. If the coordinator is using a randomly generated PAN ID, the user can get the operating PAN ID by running the AT command below on the coordinator:

AT+OPPANID or AT+OI

If the PAN ID of a ZigBee router or a ZigBee end-device is 0000, the PAN ID is ignored. After checking the PAN ID, the ZE20S trying to join compares the extended PAN ID to make sure whether the network is the right network to join. If the extended PAN ID is the same with its configured extended PAN ID, it will try to join the network. Otherwise, it will try to find another network. The user can get the operating extended PAN ID by running the AT command below on the coordinator:

AT+OPEPID or AT+OE

If the extended PAN ID of a ZigBee router or a ZigBee end-device is 0000000000000000, the extended PAN ID is ignored

3.2.4 Permit Joining

The ZigBee router is configured and works the same way with the coordinator to permit joining of other nodes. Please refer to the section **3.1.4 Permit Joining** for the configuration.

3.3 Setting up ZE20S as an End-Device

An end-device is a leaf node which communicates only with its parent node and will not relay messages directly. To configure the ZE20S as a ZigBee end-device, please follow the steps below.

- Configure the ZE20S node type as an end-device
- Optionally, select the channel mask. Otherwise, the ZE20S will use the default channel mask.
- Optionally, set up the PAN ID and/or the extended PAN ID. Otherwise, the ZE20S will scan and join the ZigBee network found automatically.
- Configure the poll timeout and the poll period

Please refer to the section **3.2 Setting up ZE20S as a Router** for the AT commands regarding the node type selection, the channel mask configuration and the PAN ID/Extended PAN ID configuration.

When an end-device joins the network, the power LED blinks periodically if GPIO15 is set to specific functionality. The end-device belongs to a parent node which is either the coordinator or a router, and the parent node registers the end-device to its internal child table for message relaying. This table is maintained as long as the end-device polls the parent node periodically within the poll timeout value of the parent node. If the end-device does not poll for the poll timeout value of the parent node, the parent node removes the end-device from its child table and does not relay the message any more. Hence, the poll period of the end-device should be equal or shorter than the poll timeout of the parent node to avoid accidental removal of the end-device from the parent node's child table.

The ZE20S poll interval can be configured by setting the S-registers using the AT commands as below.

ATS51=n, where n is poll timeout in seconds and the default is 60.

This value is for a parent node. If an end-device does not send a poll request to its parent coordinator or router within the poll timeout, the end-device is removed from the child table.

ATS56=n, where n is poll period in seconds and the default is 5.

End-device polls the parent node at poll period defined by S56 periodically. It is for the connection to the parent node and data transmission with other nodes in the network.

ATS55=n, where n is rejoin timeout and the default is 10.

When the connection to the parent node is broken for S55 in seconds, the child node tries to rejoin the current network.

Even though the end-device needs to poll the parent node continuously, it does not go into the sleep mode and it can send and receive messages any time unlike the sleepy end-device.

3.4 Setting up ZE20S as a Sleepy End-Device

A sleepy end-device can turn off radio to save power. To configure the ZE20S as a ZigBee sleepy end-device, please follow the steps below.

- Configure the ZE20S node as a sleepy end-device.
- Optionally, select the channel mask. Otherwise, the ZE20S will use the default channel mask.
- Optionally, set up the PAN ID and/or the extended PAN ID. Otherwise, the ZE20S will scan and join the ZigBee network found automatically.
- Configure the settings for sleep interval.

Please refer to the section **3.2 Setting up ZE20S as a Router** for the AT commands regarding the node type selection, the channel mask configuration and the PAN ID/Extended PAN ID configuration.

One of the unique features of the ZigBee device is its extreme low power consumption which is mainly achieved by its efficient sleep and wake-up mechanism. While ZigBee coordinator and routers are required to be in operation all the time, ZigBee sleepy end-devices can be configured to be in the sleep mode most of the time and only wake up at pre-configured time interval for data transmission before it goes into the sleep mode again. The ZE20S sleep interval can be configured by setting the S-registers using the AT commands as below.

ATS51=n, where n is poll timeout in seconds and the default is 60.

This value is for a parent node. If a sleepy end-device does not send a poll request to its parent coordinator or router within the poll timeout, the sleepy end-device is removed from the child table.

Unlike the non-sleepy end-device, sleepy end-device does not use S56 as the poll period. Instead, it uses S53 as the sleep duration which works similar to the poll period, except it goes to sleep mode.

ATS53=n, where n is sleep duration in quarter seconds and the default is 8.

The ZE20S sleeps for sleep duration and turns off radio.

ATS52=n, where n is poll period in milliseconds and the default is 100.

Sleepy end-device wakes up from the sleep mode if S53 timer expires or GPIO0 interrupt is generated or serial data is received. Once the sleepy end-device wakes up, it polls the parent node at poll period defined by S52 until it goes to sleep mode again. Since the sleepy end-device exchanges data with the parent node only by polling, S52 poll period is usually configured as around 100 ms.

ATS54=n, where n is standby timeout in seconds and the default is 5.

If there is no RF data or serial data for S54 seconds, the sleepy end-device goes to sleep mode again. If any serial or RF data is sent or received, the timer will reset and the sleepy end-device waits for another S54 seconds before it goes to sleep mode again.

$ATS55=n$, where n is rejoin timeout and the default is 10.

When the connection to the parent node is broken for S55 in seconds, the child node tries to rejoin the current network.

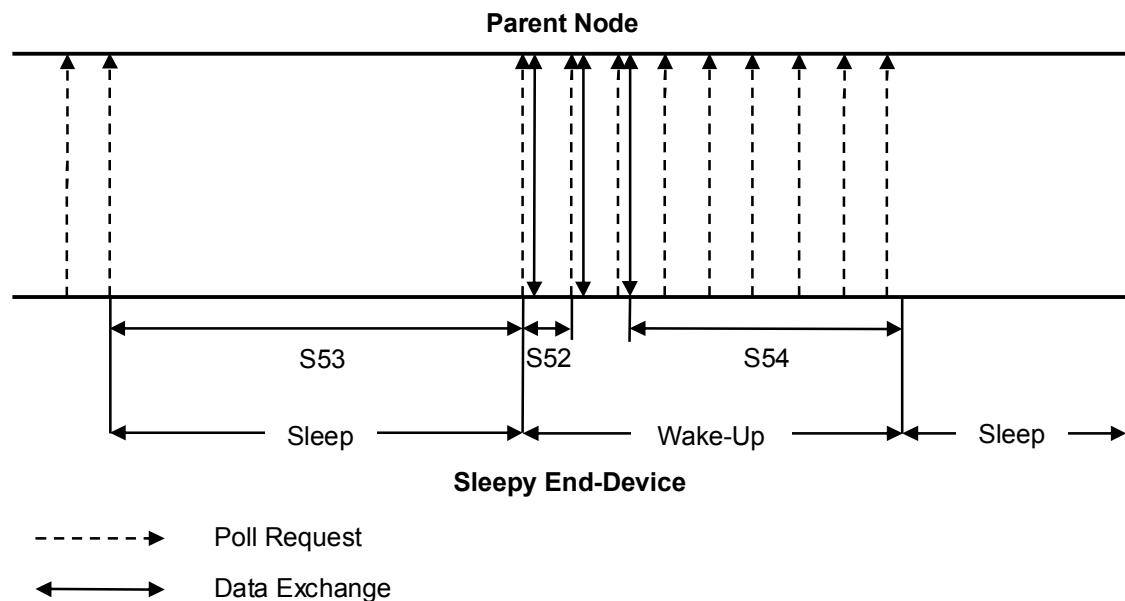

Figure 3-1 Sleep Interval and Wake-up Timing

The sleepy end-device can also wake up from the sleep mode by GPIO0 interrupt or incoming serial data. Once it wakes up, it also polls with the parent node at S52 interval and goes into sleep mode after S54 time elapses after the last data exchange.

Note: If the sleepy end-device wakes up by incoming serial data, the integrity of the first incoming byte is not guaranteed. It is strongly recommended to wake up the sleepy end-device by using GPIO0 first before sending the serial data or use higher level serial data protocol to check the data integrity.

3.5 ZigBee Security

Security is a major concern in the ZigBee architecture. Although ZigBee uses the basic security elements in IEEE 802.15.4 (e.g., AES encryption & CCM security modes), the ZE20S increases the security level with:

- 128 bit AES encryption algorithms
- Strong, NIST-approved security
- Defined Key Types (Link, Network)
- Defined Key setup and maintenance

- CCM (Unified/Simpler mode of operation)
- Trust Centers

3.5.1 Security Level

In order to use security in the application, a user should set security level using the AT command below. Set 1 defines both Authentication and Encryption at the network layer. Set 0 defines no security. Disabling security in the application is not ZigBee compliant. All nodes in the network should have the same security level setup. The security level is configured using the AT command below.

AT+SECURITY=n or AT+SE=n, where n is encryption level. (0=disable, 1=enable)

3.5.2 Link Key

The trust center (normally coordinator in network) requests link key before a device is trying to join network. If link key the device has is wrong, joining process will be denied. Hence, all nodes in the network should have the same link key setup before joining the network.

AT+LINKKEY=xxx...xxx or AT+LK= xxx...xxx, where xxx...xxx is 128-bit hexadecimal trust center link key. Default is FFF...FF.

3.5.3 Network Key

It is the network-wide key used to secure transmissions at the Network Layer. The network key encrypts all transmissions at the Network Layer. The network key only needs to be set up for the coordinator.

AT+NWKEY=xxx...xxx or AT+NK=xxx...xxx, where xxx...xxx is 128-bit hexadecimal network key. Default is FFF...FF.

3.5.4 Update Key

A trust center can update the Network Key to help minimize the risk associated with a particular instance of the network key being compromised. Key updates are broadcast by the trust center throughout the network, encrypted using the current network key. Devices that hear the broadcast will not immediately use the key, but simply store it. Later, a key switch is broadcast by the trust center to tell all nodes to start using the new key. At a minimum, the trust center should allow adequate time for the broadcast of the new key to propagate throughout the network before switching.

AT+UPDATEKEY<CR> or AT+UK<CR>

3.6 Frequency Agility

Frequency Agility refers to the function to shift operating channel to avoid interference. If frequency agility function of coordinator is enabled, the coordinator plays a role in network manager. It monitors communication failures, decides to changes the operating channel and send message to indicate the

channel change. Other nodes in the network move to the designated channel by responding to the message.

The frequency agility needs to be set up only for the coordinator.

ATS71=n, where n is 0 = disabled, 1 = enabled.

4 Digital and Analog I/O

4.1 GPIO (General Purpose Inputs and Outputs) Configuration

The ZE20S module has total 18 I/O pins. Among these pins, I/O pin 2 is assigned to factory reset only and the user can use the rest 17 pins for general purpose inputs and outputs. The I/O pin assignments are shown in Table 4-1. As shown in Table 4-1, some pins provide special functions built into the firmware. Table 4-2 describes the special functions tied to the specific pins.

Table 4-1 Default I/O Pin Assignments

Pin Number	GPIO Number	Special Functions	AI Enable
2	-	Factory reset / Bootloader (SW_0)	X
3	0	Permit joining / Wake-up (SW_1)	X
4	1	UART_DTR	X
5	2	UART_DSR	X
6	3	UART_CTS	X
7	4	UART_RTS	X
8	5		X
9	6		X
10	7		X
11	8		X
32	9		O (AI_0)
31	10		O (AI_1)
30	11		O (AI_2)
29	12		O (AI_3)
28	13		O (AI_4)
27	14		O (AI_5)
24	15	Power LED (LED_0)	X
23	16	Status LED (LED_1)	X

The AT command below can be used to change the GPIO settings.

AT+GPIO=<values><CR> or AT+GPIO<number>=<value><CR>

, where <values> is a number between 0~6 as explained below:

- 0 Disabled (unmonitored digital input)
- 1 Digital input, monitored
- 2 Digital output, default low
- 3 Digital output, default high
- 4 Analog input, single ended (only valid for GPIO9~14)
- 5 Reserved for pin-specific alternate functionalities (See Table 4-2)
- 6 Home Automation GPIO (only valid for ProBeeHADL and ProBeeHAOL)

Home Automation GPIO is treated in this document. Please refer to ProBee-ZE20S User Guide for usage of such options digital input, digital output and analog input.

Table 4-2 Special GPIO Pins

Function	GPIO#	Type	Description
Factory_reset / Bootloader	-	DI	This input is dedicated for the factory reset button. If user wants to restore the ZE20S device settings to factory default, this input (falling edge, i.e. High to Low change) needs to be pressed for more than two seconds. It will be applied after the input released again. If this input is pressed while the ZE20S starts, the local node enters bootloader menu and it is possible to upload the firmware. Factory reset button is not available when the ZE20S device is sleeping.
Permit_joining / Wake-up	0	DI	This input (falling edge, i.e. High to Low change) is used to permit joining or interrupt sleeping. This function is activated when GPIO0 is set to 5. The functions depend on the node type of the ZE20S. If the node is set to coordinator or router, this input works to permit other nodes joining for Permit joining timeout(S-register 22 value). If the node is set to sleepy end-device, it is used for wake-up signal when the node is sleeping.
UART_CTS	1	DI	This input is used for UART CTS if GPIO1 is set to 5. It should be enabled when CTS flow control is used.
UART_RTS	2	DO	This output is used for UART RTS if GPIO2 is set to 5. It should be enabled when RTS flow control is used.
UART_DTR	3	DO	This output is used for UART DTR if GPIO3 is set to 5.
UATR_DSR	4	DI	This input is used for UART DSR if GPIO4 is set to 5.
Power LED	15	DO	If GPIO15 is set to 5, this output turns ON (High) when power is supplied. If the node is set to an end-device, it will blink periodically. Please refer to 8 S-Registers for S14 regarding the management of the LED status.
Status LED	16	DO	If GPIO16 is set to 5, this output turns ON (High) when the device joins a network, blinks when joining is permitted, and turns OFF (Low) when leaves the network. Please refer to 8 S-Registers for S14 regarding the management of the LED status.

4.2 HA GPIO

The ZE20S can be configured to make its GPIO cooperate with HA profile. To use this function, you should set any GPIO pin to 6(HA GPIO) and reboot ZE20S board. Whenever HA state attribute is changed, GPIO output is changed accordingly and you can monitor state attribute by GPIO pins. If you set several pins for HA GPIO, all the pins will work same way. Following table shows which HA attribute in

which cluster is assigned to HA GPIO in each ProBeeHA firmware.

Table 4-3 Attribute assigned to HA GPIO

Device Name	Assigned Cluster	Assigned Attribute	On value	Off value
ProBeeHACI	-	-	-	-
ProBeeHADL	Door Lock(0x0101)	Lock state(0x0000)	1	0
ProBeeHAOL	On/Off(0x0006)	On/Off(0x0000)	1	0

AT commands can be used as below.

AT+GPIOx=6

Example)

```

AT+GPIO3=6<CR>           # Set GPIO3 to HA GPIO
OK                         # Response
AT+GPIO8=6<CR>           # Set GPIO8 to HA GPIO
OK                         # Response
ATZ<CR>                   # Reset and apply GPIO setting
OK                         # Response
AT+VERSION<CR>           # Check firmware version
HADLv1.8                  # ProBeeHADL - Door Lock
OK                         # Response
AT+ATTR=0101              # Show Door Lock attribute command
clus|attr|data(clusterName)
0101|0000|00 (Door Lock)  # Door Lock State(0x0000) is 00,
                          # HA GPIO pins are off now
0101|0001|00 (Door Lock)
0101|0002|00 (Door Lock)
...
0101|0030|0000 (Door Lock)
0101|0040|0100 (Door Lock)
0101|0050|00 (Door Lock)
OK                         # Response

```

5 Working with Development Kit

The ZE20S development kit provides a quick and easy way to be familiar with the ZE20S and test its functionalities before you build your own PCB board to carry the ZE20S. It is always recommended to start with the ZE20S development kit before your own design.

5.1 Development Kit Contents

The development kit consists of ZE20S modules and development boards to carry them. The development board provides RS232 and USB interface to interface with computers and/or your target devices. It provides terminals for digital inputs/outputs and analog inputs, too. It also provides on/off switches and LEDs to simulate and verify digital inputs/outputs. In addition, it has temperature and light sensor so you can test more practical applications. Below is the list of the items included in the package.

- ProBee ZE20S ZigBee OEM Module w/ Chip Antenna (ProBee-ZE20SDC) (1)
- ProBee ZE20S ZigBee OEM Module w/ U.FL Connector (ProBee-ZE20SDU) (1)
- ProBee ZE20S ZigBee OEM Module w/ RPSMA Connector (ProBee-ZE20SDS) (1)
- 3 dBi Dipole Antenna, RP-SMA Plug, Right-hand Thread (2)
- 12cm U.FL to RPSMA Cable, Right-Hand Thread (1)
- Development Boards (3)
- DC Power Adapters (3)
- RS232 Serial Cable (3)
- USB Cable (3)

5.2 Development Board Features

The development board is designed to provide convenient access to the ZE20S interface pins. The development board provides external interfaces as below. Also Figure 5-1 shows the layout of those interfaces of the development board.

- RS232 Interface
- USB Interface
- 3 Pre-defined Digital Inputs: Hardware Reset, Factory Default Reset, Permit Joining
- 8 User Configurable Digital Input Buttons
- 8 Digital Outputs with LEDs (Active High)
- 4 Analog Inputs
- Temperature Sensor
- Light Sensor

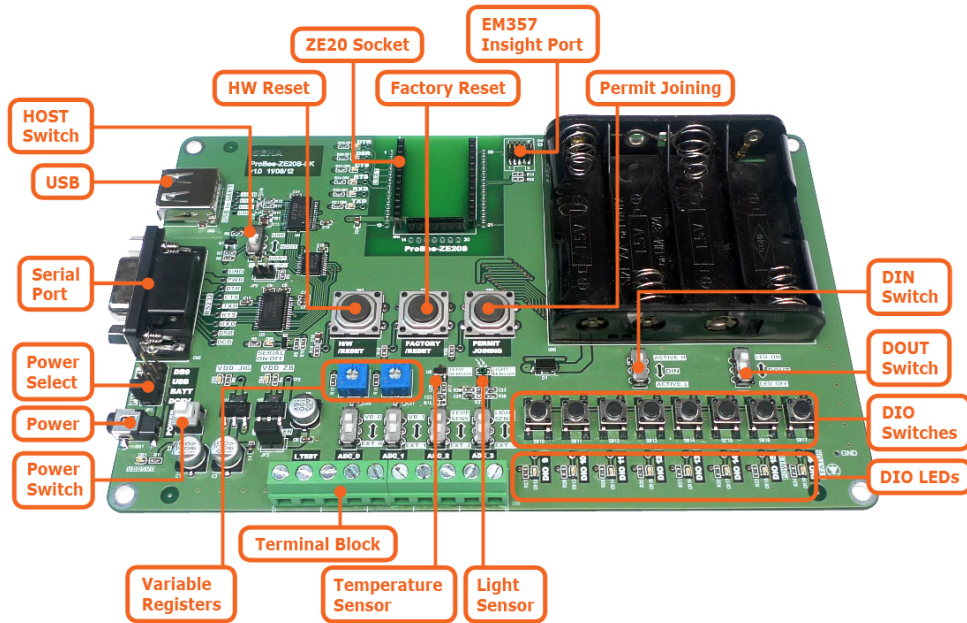

Figure 5-1 Development Board Layout

5.3 Development Board Hardware Descriptions

5.3.1 Power

There are four ways to supply power to the development board:

- 5V Power Adapter
- USB Port
- Batteries (AA 1.5V x 4)
- RS232 Port (5V through 9th Pin)

The PWR_SEL(JP1) jumper MUST be configured properly according to the way to supply power. Table 5-1 shows jumper configuration.

Table 5-1 Jumpers Configuration

		5V Power Adapter	Batteries	USB Port	RS232 Port
PWR_SEL	DB9				
	USB				
	BATT				
	DC5V				

5.3.2 RS232 Port

The development board has an RS232 interface for UART communication. The UART_TXD, UART_RXD, UART_DSR (GPIO_1), UART_DTR (GPIO_2), UART_CTS (GPIO_3) and UART_RTS (GPIO_4) pins of the ZE20S are connected with the RS232 port. To enable the RS232 port, the HOST (SW2) switch should be set to UART.

In addition to the data communication via RS232 port, the RS232 port is capable of supplying power to the development board. In order to use this feature, supply 5V power via the 9th pin of the DB9 socket.

5.3.3 USB Port

The development board also has a USB interface for UART communication. To use the USB port, the HOST (SW2) switch should be set to USB and the software driver should be installed on the host computer. The installation CD contains the software.

5.3.4 ZE20S GPIO Interface

The development board's external GPIO interfaces as well as functional buttons such as factory default reset switches are internally routed to the ZE20S GPIO pins. Table 5-2 summarizes the development board's interfaces and their corresponding GPIO pin numbers of the ZE20S.

Table 5-2 Development Board GPIO Interface Allocation

ZE20S Pin Number	Name	Description
2	Factory Reset	Factory Default Reset Switch (SW8)
3	GPIO_0	Permit Joining Switch (SW9)
4	GPIO_1	UART DTR Output
5	GPIO_2	UART DSR Input
6	GPIO_3	UART CTS Input
7	GPIO_4	UART RTS Output
22	H/W Reset	Hardware Reset Switch
23	GPIO_16	Digital Output with LED(CR19) Display (Active High) Digital Input with Button Switch (SW17, Active Low or Active High)
24	GPIO_15	Digital Output with LED(CR18) Display (Active High) Digital Input with Button Switch (SW16, Active Low or Active High)
25	UART_RXD	UART Data Input
26	UART_TXD	UART Data Output
27	GPIO_14	Digital Output with LED(CR17) Display (Active High) Digital Input with Button Switch (SW15, Active Low or Active High)
28	GPIO_13	Digital Output with LED(CR16) Display (Active High) Digital Input with Button Switch (SW14, Active Low or Active High)
29	GPIO_12	Digital Output with LED(CR15) Display (Active High) Digital Input with Button Switch (SW13, Active Low or Active High) Analog Input with Light Sensor (U7)
30	GPIO_11	Digital Output with LED(CR14) Display (Active High) Digital Input with Button Switch (SW12, Active Low or Active High) Analog Input with Temperature Sensor (U6)

31	GPIO_10	Digital Output with LED(CR13) Display (Active High) Digital Input with Button Switch (SW11, Active Low or Active High) Analog Input with Variable Register (VR2)
32	GPIO_9	Digital Output with LED(CR12) Display (Active High) Digital Input with Button Switch (SW10, Active Low or Active High) Analog Input with Variable Register (VR1)

5.3.5 LEDs (CR12-19)

The development board has 8 LEDs for digital output. To enable the LEDs, the GPIO_OUT (SW20) switch should be set to LED_ON. The LEDs are turned on when the related GPIO pins of the ZE20S are high.

Note: The ADC_0~3 switches (SW4~7) should be placed to EXT_0~3.

5.3.6 Button Switches (SW10-17)

The development board has 8 button switches for digital input. The switches can be configured as active high or active low with the GPIO_IN (SW19) switch.

Note: The ADC_0~3 switches (SW4~7) should be placed to EXT_0~3.

Note: The LED On/Off switch (SW20) should be placed to LED_OFF.

Note: If the GPIO_IN (SW19) is set to Active High, GPIO pull up/down option should be set to Pull-Down (ATS41=0). If the GPIO_IN (SW19) is set to Active Low, GPIO pull up/down option should be set to Pull-Up. (ATS41=1)

5.3.7 Variable Resistors (VR1, VR2)

There are two variable resistors for analog inputs on the development board. The analog inputs can be read with the GPIO_9 and GPIO_10. To enable the variable resistors, the ADC_0 and ADC_1 switches should be placed to VR_0 and VR_1.

Note: The LED On/Off switch (SW20) should be placed to LED_OFF.

5.3.8 Temperature Sensor

The GPIO_11 of the ZE20S is routed to the temperature sensor. The relationship between temperature and analog input is as follows:

$$\text{Temperature}(\text{°C}) = \{ \text{Volt}(\text{mV}) - 600(\text{mV}) \} * 0.1(\text{°C/mV})$$

Note: The LED On/Off switch (SW20) should be placed to LED_OFF.

5.3.9 Light Sensor

The GPIO_12 of the ZE20S is routed to the light sensor. Approximately, the relationship between

illumination and analog input is as follows:

$$\text{Illumination(Lux)} = \text{Volt(mV)} * 0.25(\text{Lux/mV})$$

Note: The LED On/Off switch (SW20) should be placed to LED_OFF.

5.3.10 Terminal Block

The development board has a terminal block for external analog inputs. Figure 5-2 shows the layout of the terminal block. To use external analog inputs instead of the variable resistors, temperature sensor or light sensor, the ADC_0 (SW4), ADC_1 (SW5), ADC_2 (SW6) or ADC_3 (SW7) should be placed on EXT_0, EXT_1, EXT_2, or EXT_3.

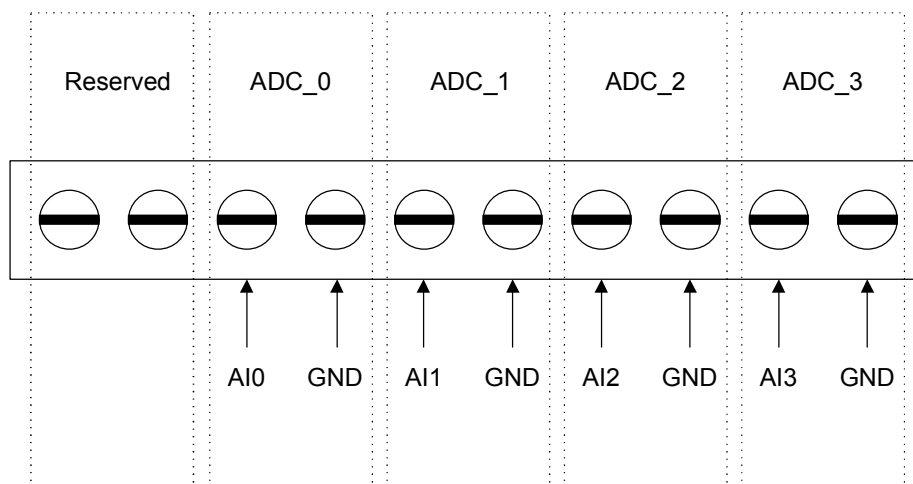

Figure 5-2 Terminal Block for External Analog Inputs

Note: The LED On/Off switch (SW20) should be placed to LED_OFF.

5.4 Configuration Example: 1 Coordinator and 2 End-Devices

Here is another example assuming different system configurations. This example can be described as follows:

- One ZE20S module acts as a ProBeeHACI coordinator and it is connected to a host computer via USB cable.
- One ZE20S module acts as a ProBeeHADL end device and it receives control commands from the coordinator.
- One ZE20S module acts as a ProBeeHAOL end device and it receives control commands from the coordinator.

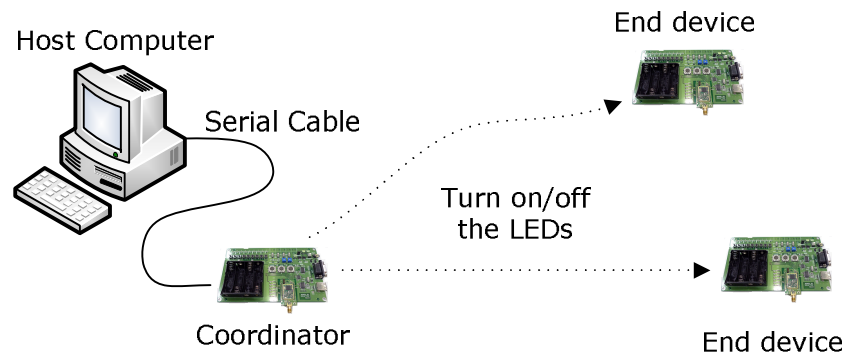

Figure 5-3 Example #2: 1 Coordinator and 2 End-Devices

5.4.1 ProBeeHACI Coordinator Configuration

Hardware configuration for the coordinator is as follows:

- Set the HOST switch to UART
- Connect a serial cable between a host computer and the coordinator
- Update ProBeeHACI firmware (See Chapter 2.3.3)

The AT commands for coordinator configuration is as follows:

```
AT+NODETYPE=1
OK
AT+PANID=7772
OK
ATZ
OK
```

5.4.2 ProBeeHADL End-device Configuration

Hardware configuration for the coordinator is as follows:

- Set the GPIO_OUT switch to LED_ON
- Update ProBeeHADL firmware (See Chapter 2.3.3)

The AT commands for the ProBeeHADL end-device are as follows:

```
AT+NODETYPE=3
OK
AT+PANID=7772
OK
AT+GPIO=6666666666666666
OK
```

```
AT+LONGADDR
0001950000000005
OK
ATZ
OK
```

5.4.3 ProBeeHAOL End-device Configuration

Hardware configuration for the coordinator is as follows:

- Set the GPIO_OUT switch to LED_ON
- Update ProBeeHAOL firmware (See Chapter 2.3.3)

The AT commands for the ProBeeHAOL end-device are as follows:
(Same as ProBeeHADL end-device)

```
AT+NODETYPE=3
OK
AT+PANID=7772
OK
AT+GPIO=6666666666666666
OK
AT+LONGADDR
0001950000000003
OK
ATZ
OK
```

5.4.4 Turning on/off the ProBeeHADL End Device LEDs from ProBeeHACI Coordinator

The AT commands to turn on the LEDs of the ProBeeHADL End Device are as follows:

```
AT+ADDRDISCOVERY=0001950000000005
B862
OK
AT+DEST=B862,01
OK
AT+CWRITE=0101,0000,01
OK
```

* Short address 'B862' can be shown differently in your device.

The AT commands to turn off the LEDs of the ProBeeHADL End Device are as follows:

```
AT+CWRITE=0101,0000,00
```

```
OK
```

5.4.5 Turning on/off the ProBeeHAOL End-device LEDs from ProBeeHACI Coordinator

The AT commands to turn on the LEDs of the ProBeeHAOL end-device are as follows:

```
AT+ADDRDISCOVERY=0001950000000003
```

```
38A5
```

```
OK
```

```
AT+DEST=38A5,01
```

```
OK
```

```
AT+ON
```

```
OK
```

* Short address '38A5' can be shown differently in your device.

The AT commands to turn off the LEDs of the ProBeeHAOL End Device are as follows:

```
AT+OFF
```

```
OK
```

6 HA(Home Automation) Profile Descriptions

6.1 Device Descriptions

Device descriptions specified in this profile are summarized in following Table 6-1, “Devices Specified in the HA Profile”. The devices are organized according the end application areas they address. A product that conforms to this specification shall implement at least one of these device descriptions and shall also include the device descriptions corresponding to all applications implemented on the product where a standard device description is specified in this profile. For example, if a product implements both a light dimmer and a light sensor application, then the Dimmable Light and Light Sensor device descriptions must both be supported. This list will be added to in future versions of the profile as new clusters are developed to meet the needs of manufacturers. The reserved values shall not be used until the profile defines them. Manufacturer-specific device descriptions shall reside on a separate endpoint and use a private profile ID.

Table 6-1 Devices Specified in the HA Profile

	Device	Device ID
Generic	On/Off Switch	0x0000
	Level Control Switch	0x0001
	On/Off Output	0x0002
	Level Controllable Output	0x0003
	Scene Selector	0x0004
	Configuration Tool	0x0005
	Remote Control	0x0006
	Combined Interface (Supported in ProBeeHACI)	0x0007
	Range Extender	0x0008
	Mains Power Outlet	0x0009
	Door Lock (Supported in ProBeeHADL)	0x000A
	Door Lock Controller	0x000B
	Simple Sensor	0x000C
Lighting	On/Off Light	0x0100
	Dimmable Light	0x0101
	Color Dimmable Light (Supported in ProBeeHAOL)	0x0102
	On/Off Light Switch	0x0103
	Dimmer Switch	0x0104
	Color Dimmer Switch	0x0105
	Light Sensor	0x0106
	Occupancy Sensor	0x0107
Closure	Shade	0x0200
	Shade Controller	0x0201

	Window Covering Device	0x0202
	Window Covering Controller	0x0203
HVAC	Heating/Cooling Unit	0x0300
	Thermostat	0x0301
	Temperature Sensor	0x0302
	Pump	0x0304
	Pump Controller	0x0305
	Pressure Sensor	0x0306
	Flow Sensor	0x0307
Intruder Alarm Systems	IAS Control and Indicating Equipment	0x0400
	IAS Ancillary Control Equipment	0x0401
	IAS Zone	0x0402
	IAS Warning Device	0x0403

6.2 ZigBee Cluster Library (ZCL)

This profile utilizes the clusters specified in the ZigBee Cluster Library. The implementation details for each cluster are given in the ZCL specifications. Further specification and clarification are given in this profile where necessary. The ZCL provides a mechanism for clusters to report changes to the value of various attributes. It also provides commands to configure the reporting parameters. The attributes that a particular cluster is capable of reporting are listed in the ZCL specification for each cluster. Products shall support the reporting mechanism for all attributes specified in the ZCL that the product implements within a given cluster. The tables in **6.4 ProBee HA Profiles Description** show which clusters are supported in ProBeeHAxx firmwares and which attributes / commands are available in each cluster.

6.3 Cluster Binding

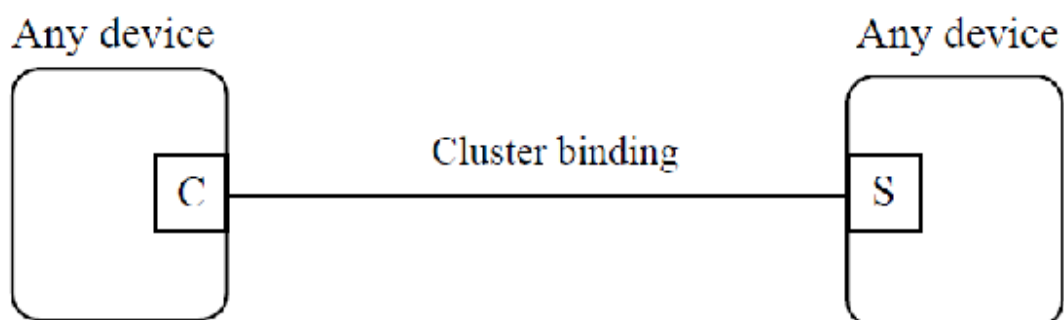

Figure 6-1 The ZCL Client Server Model

A cluster is a related collection of commands and attributes, which together define an interface to specific functionality. Typically, the entity that stores the attributes of a cluster is referred to as the server of that cluster and an entity that affects or manipulates those attributes is referred to as the client of that cluster. However, if required, attributes may also be present on the client of a cluster.

Commands that allow devices to manipulate attributes, the “read attribute” (AT+CREAD, AT+SREAD) or “write attribute” (AT+CWRITE, AT+SWRITE) commands, are sent from a client device and received by the server device. Any response to those commands, the “read attribute” response or the “write attribute” response commands, are sent from the server device and received by the client device.

The clusters supported by an application object within an application profile are identified through the simple descriptor (see Chapter 3), specified on each active endpoint of a device. In the simple descriptor, the application input cluster list shall contain the list of server clusters supported on the device and the application output cluster list shall contain the list of client clusters supported on the device.

ProBee supports 3 HA profiles (ProBeeHACI, ProBeeHADL, ProBeeHAOL) and at least two nodes with HA profile are necessary to test cluster binding and HA interaction. Following figure shows which profile clusters can communicate other ProBee HA profiles.

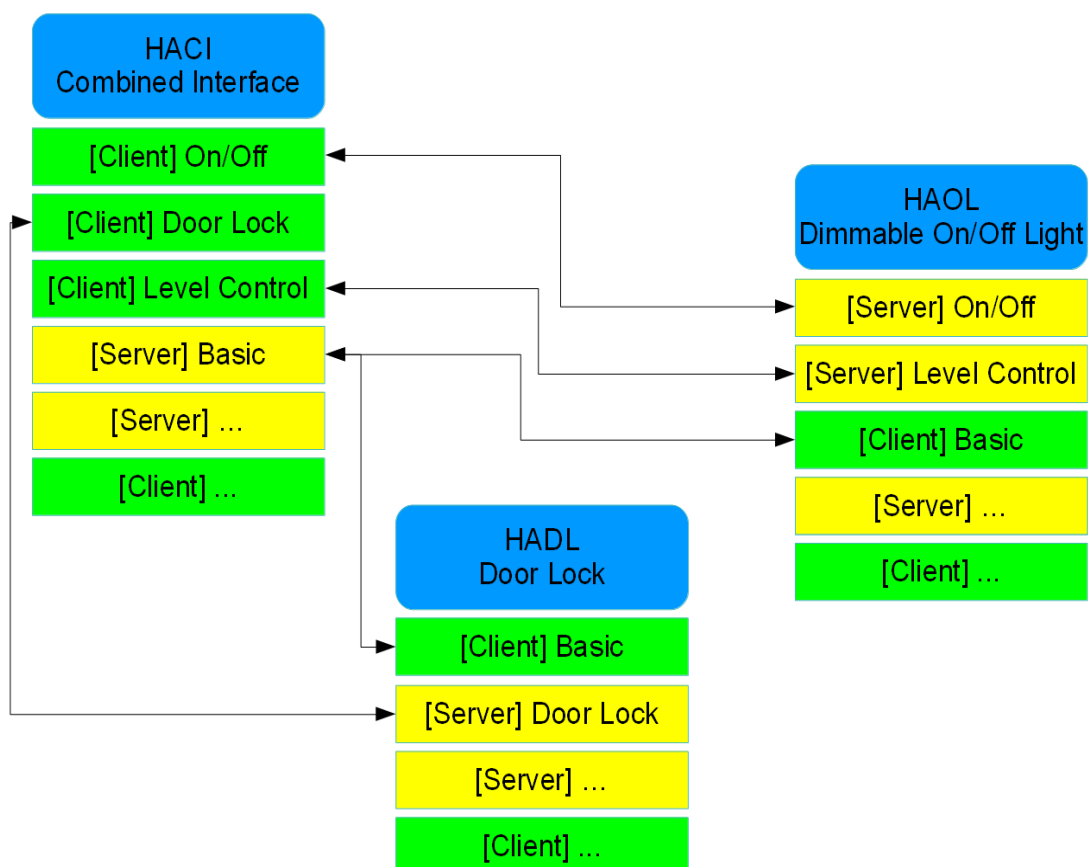

Figure 6-2 ProBee HA profile cluster binding diagram

6.4 ProBee HA Profiles Description

6.4.1 ProBeeHACI (Combined Interface)

The Combined Interface device is capable of controlling and monitoring other devices. It is typically a mains-powered device like a personal computer.

6.4.1.1 Cluster Support

Table 6-2 ProBeeHACI Cluster Support

Server Side	Client Side
Basic	Basic
Device Temperature Configuration	Color Control
Identify	Door Lock
Power Configuration	Identify
	Level Control
	On/Off
	On/Off Switch Configuration
	Thermostat

6.4.1.2 Attributes

Table 6-3 ProBeeHACI Attributes

Cluster ID	Cluster name	Attribute ID	Attribute name	Type
0x0000	Basic	0x0000	ZCL version	INT8U
		0x0001	Application version	INT8U
		0x0002	Stack version	INT8U
		0x0003	Hardware version	INT8U
		0x0007	Power source	ENUM8
		0x0011	Physical environment	ENUM8
		0x0012	Device enabled	BOOLEAN
		0x0013	Alarm mask	BITMAP8
		0x0014	Disable local config	BITMAP8
0x0001	Power Configuration	0x0000	Mains voltage	INT16U
		0x0001	Mains frequency	INT8U
		0x0020	Battery voltage	INT8U

		0x0031	Battery size	ENUM8
		0x0032	Battery ahr rating	INT16U
		0x0033	Battery quantity	INT8U
		0x0034	Battery rated voltage	INT8U
0x0002	Device Temperature Configuration	0x0000	Current temperature	INT16S
		0x0001	Min temp experienced	INT16S
		0x0002	Max temp experienced	INT16S
		0x0003	Over temp total dwell	INT16U
		0x0010	Device temp alarm mask	BITMAP8
		0x0011	Low temp threshold	INT16S
		0x0012	High temp threshold	INT16S
		0x0013	Low temp dwell trip point	INT24U
		0x0014	High temp dwell trip point	INT24U
0x0003	Identify	0x0000	Identify time	INT16U

6.4.1.3 Commands

Table 6-4 ProBeeHACI Commands

Cluster ID	Cluster name	Comm and ID	Command name	Side	Pay load	AT Command
0x0000	Basic	0x00	Reset to Factory Defaults	C	-	AT+FACTORYRESET
0x0003	Identify	0x00	Identify	C	2	-
		0x01	Identify Query	C	-	AT+CCMD
		0x00	Identify Query Response	S	2	-
0x0006	On/Off	0x00	Off	C	-	AT+ON
		0x01	On	C	-	AT+OFF
		0x02	Toggle	C	-	AT+TOGGLE
0x0008	Level Control	0x00	Move to Level	C	3	AT+MVTOLVL
		0x01	Move	C	2	-
		0x02	Step	C	4	-
		0x03	Stop	C	-	AT+CCMD

		0x04	Move to Level (with On/Off)	C	3	-
		0x05	Move (with On/Off)	C	2	-
		0x06	Step (with On/Off)	C	4	-
		0x07	Stop	C	-	AT+CCMD
0x0101	Door Lock	0x00	Lock Door	C	-	AT+LOCK
		0x01	Unlock Door	C	-	AT+UNLOCK
0x0300	Color Control	0x00	Move to Hue	C	4	-
		0x01	Move Hue	C	2	-
		0x02	Step Hue	C	3	-
		0x03	Move to Saturation	C	3	-
		0x04	Move Saturation	C	2	-
		0x05	Step Saturation	C	3	-
		0x06	Move to Hue and Saturation	C	4	-
		0x07	Move to Color	C	6	-
		0x08	Move Color	C	4	-
		0x09	Step Color	C	6	-
		0x0A	Move to Color Temperature	C	4	-

6.4.2 ProBeeHADL (Door Lock)

The Door Lock is capable of receiving Door Lock cluster commands.

6.4.2.1 Cluster Support

Table 6-5 ProBeeHADL Cluster Support

Server Side	Client Side
Basic	
Device Temperature Configuration	
Door Lock	
Groups	
Identify	
Power Configuration	
Scenes	

6.4.2.2 Attributes

Table 6-6 ProBeeHADL Attributes

Cluster ID	Cluster name	Attribute ID	Attribute name	Type
0x0000	Basic	0x0000	ZCL version	INT8U
		0x0001	Application version	INT8U
		0x0002	Stack version	INT8U
		0x0003	Hardware version	INT8U
		0x0007	Power source	ENUM8
		0x0011	Physical environment	ENUM8
		0x0012	Device enabled	BOOLEAN
		0x0013	Alarm mask	BITMAP8
		0x0014	Disable local config	BITMAP8
0x0001	Power Configuration	0x0000	Mains voltage	INT16U
		0x0001	Mains frequency	INT8U
		0x0020	Battery voltage	INT8U
		0x0031	Battery size	ENUM8
		0x0032	Battery ahr rating	INT16U
		0x0033	Battery quantity	INT8U
		0x0034	Battery rated voltage	INT8U
0x0002	Device Temperature Configuration	0x0000	Current temperature	INT16S
		0x0001	Min temp experienced	INT16S
		0x0002	Max temp experienced	INT16S
		0x0003	Over temp total dwell	INT16U
		0x0010	Device temp alarm mask	BITMAP8
		0x0011	Low temp threshold	INT16S
		0x0012	High temp threshold	INT16S
		0x0013	Low temp dwell trip point	INT24U
		0x0014	High temp dwell trip point	INT24U
0x0003	Identify	0x0000	Identify time	INT16U

0x0004	Groups	0x0000	Name support	BITMAP8
0x0005	Scenes	0x0000	Scene count	INT8U
		0x0001	Current scene	INT8U
		0x0002	Current group	INT16U
		0x0003	Scene valid	BOOLEAN
		0x0004	Name support	BITMAP8
0x0101	Door Lock	0x0000	Lock state	ENUM8
		0x0001	Lock type	ENUM8
		0x0002	Actuator enabled	BOOLEAN
		0x0003	Door state	ENUM8
		0x0004	Door open events	INT32U
		0x0005	Door closed events	INT32U
		0x0006	Open period	INT16U
		0x0012	Auto relock timeout	INT8U
		0x0013	Wrong code entry limit	INT8U
		0x0014	Shut down time	INT8U
		0x0015	Battery level	INT8U
		0x0017	Silent mode	INT8U
		0x0018	Operating mode	INT8U
		0x0019	language	INT8U
		0x001A	All codes lockout	BOOLEAN
		0x0020	Enable logging	BOOLEAN
		0x0021	Num log records supported	INT16U
		0x0030	Num user codes supported	INT16U
		0x0040	Num schedule slots per user	INT16U
		0x0050	Alarm mask	BITMAP8

6.4.2.3 Commands

Table 6-7 ProBeeHADL Commands

Cluster ID	Cluster name	Command ID	Command name	Side	Pay load	AT Command
0x0000	Basic	0x00	Reset to Factory Defaults	C	-	AT+FACTORYRESET
0x0003	Identify	0x00	Identify	C	2	-
		0x01	Identify Query	C	-	-
		0x00	Identify Query Response	S	2	-
0x0004	Groups	0x00	Add group response	S	3	-
		0x01	View group response	S	V	-
		0x02	Get group membership response	S	V	-
		0x03	Remove group response	S	3	-
0x0005	Scenes	0x00	Add scene response	S	4	-
		0x01	View scene response	S	V	-
		0x02	Remove scene response	S	4	-
		0x03	Remove all scenes response	S	3	-
		0x04	Store scene response	S	4	-
		0x06	Get scene membership response	S	V	-
0x0101	Door Lock	0x00	Lock Door Response	S	1	AT+RLOCK
		0x01	Unlock Door Response	S	1	AT+RUNLOCK

6.4.3 ProBeeHAOL (Color Dimmable Light)

The Color Dimmable Light device can be switched on and off, and its luminance, hue, and saturation levels may be controlled.

6.4.3.1 Cluster Support

Table 6-8 ProBeeHAOL Cluster Support

Server Side	Client Side
Basic	
Color Control	
Device Temperature Configuration	

Groups	
Identify	
Level Control	
On/Off	
Power Configuration	
Scenes	

6.4.3.2 Attributes

Table 6-9 ProBeeHAOL Attributes

Cluster ID	Cluster name	Attribute ID	Attribute name	Type
0x0000	Basic	0x0000	ZCL version	INT8U
		0x0001	Application version	INT8U
		0x0002	Stack version	INT8U
		0x0003	Hardware version	INT8U
		0x0007	Power source	ENUM8
		0x0011	Physical environment	ENUM8
		0x0012	Device enabled	BOOLEAN
		0x0013	Alarm mask	BITMAP8
		0x0014	Disable local config	BITMAP8
0x0001	Power Configuration	0x0000	Mains voltage	INT16U
		0x0001	Mains frequency	INT8U
		0x0020	Battery voltage	INT8U
		0x0031	Battery size	ENUM8
		0x0032	Battery ahr rating	INT16U
		0x0033	Battery quantity	INT8U
		0x0034	Battery rated voltage	INT8U
0x0002	Device Temperature Configuration	0x0000	Current temperature	INT16S
		0x0001	Min temp experienced	INT16S
		0x0002	Max temp experienced	INT16S

		0x0003	Over temp total dwell	INT16U
		0x0010	Device temp alarm mask	BITMAP8
		0x0011	Low temp threshold	INT16S
		0x0012	High temp threshold	INT16S
		0x0013	Low temp dwell trip point	INT24U
		0x0014	High temp dwell trip point	INT24U
0x0003	Identify	0x0000	Identify time	INT16U
0x0004	Groups	0x0000	Name support	BITMAP8
0x0005	Scenes	0x0000	Scene count	INT8U
		0x0001	Current scene	INT8U
		0x0002	Current group	INT16U
		0x0003	Scene valid	BOOLEAN
		0x0004	Name support	BITMAP8
0x0006	On/Off	0x0000	On/off	BOOLEAN
		0x4000	Global scene control	BOOLEAN
		0x4001	On time	INT16U
		0x4002	Off wait time	INT16U
0x0008	Level Control	0x0000	Current level	INT8U
		0x0001	Remaining time	INT16U
		0x0010	On off transition time	INT16U
		0x0011	On level	INT8U
		0x0012	On transition time	INT16U
		0x0013	Off transition time	INT16U
		0x0014	Default move rate	INT16U
0x0300	Color Control	0x0000	Current hue	INT8U
		0x0001	Current saturation	INT8U
		0x0002	Remaining time	INT16U
		0x0003	Current x	INT16U
		0x0004	Current y	INT16U

6.4.3.3 Commands

Table 6-10 ProBeeHAOL Commands

Cluster ID	Cluster name	Comm and ID	Command name	Side	Pay load	AT Command
0x0000	Basic	0x00	Reset to Factory Defaults	C	-	AT+FACTORYRESET
0x0003	Identify	0x00	Identify	C	2	-
		0x01	Identify Query	C	-	-
		0x00	Identify Query Response	S	2	-
0x0004	Groups	0x00	Add group response	S	3	-
		0x01	View group response	S	V	-
		0x02	Get group membership response	S	V	-
		0x03	Remove group response	S	3	-
0x0005	Scenes	0x00	Add scene response	S	4	-
		0x01	View scene response	S	V	-
		0x02	Remove scene response	S	4	-
		0x03	Remove all scenes response	S	3	-
		0x04	Store scene response	S	4	-
		0x06	Get scene membership response	S	V	-

7 AT Command Reference

7.1 Command Line Format

Each command line is composed of a prefix, body and terminator. Only “AT” can be used for the prefix. The body is a string of characters. The terminator is <CR> or <NL>. A command can be one of the followings:

- Read a configuration parameter:
AT<Command>?<CR>
- Do something:
AT<Command><CR>
- Write a configuration parameter:
AT<Command>=<Parameter 1>,<Parameter 2>,<Parameter 3>,...<CR>

Commands denoted with a “+” character are extended AT commands.

S-registers are supported. Multiple commands in the same command line are not supported.

7.2 Standard AT Commands

7.2.1 AT

Description	Check the state of the connection between host and ProBee device.
Execute	AT<CR>
Response	OK<CR>

7.2.2 ATE

Description	Echo(1) or No Echo(0).
Execute	ATE<number><CR>
Response	OK<CR>

7.2.3 ATR

Description	Response(1) or No Response(0).
Execute	ATR<number><CR>
Response	OK<CR>

7.2.4 ATS

Description	Get/Set the S-registers.		
Execute	ATS<CR>	ATS<number>?<CR>	ATS<number>=<value><CR>

Response	List of the S-register and description	<value><CR> OK<CR>	OK<CR> or ERROR<CR>
----------	--	-----------------------	---------------------

7.2.5 ATZ

Description	Reset the node.
Execute	ATZ<CR>
Response	OK<CR>

7.2.6 AT&F

Description	Factory reset.
Execute	AT&F<CR>
Response	OK<CR>

7.3 Node Specific Information

7.3.1 AT+LONGADDR or AT+LA

Description	Get the 64-bit IEEE address. (EUI address, long address) The IEEE address is a unique device address assigned during manufacturing. This address is unique to each physical device.
Execute	AT+LONGADDR?<CR>
Response	<IEEE address><CR> OK<CR>

7.3.2 AT+SHORTADDR or AT+SA

Description	Get the 16-bit Node ID. (network address, short address) The node ID of "0000" is reserved for the coordinator. All other devices receive a randomly generated address from the coordinator or router device that allows the join. This value can change if an address conflict is detected where two devices are found to have the same address or a device leaves the network and later joins.
Execute	AT+SHORTADDR?<CR>
Response	<node ID><CR> OK<CR>

7.3.3 AT+ADDRDISCOVERY or AT+AD

Description	Get the corresponding address of a node whose long or short address is known.	
Execute	AT+ADDRDISCOVERY=<IEEE><CR>	AT+ADDRDISCOVERY=<nodeID><CR>
Response	<node ID><CR> OK<CR>	<IEEE address><CR> OK<CR>

7.3.4 AT+OPCH or AT+OC

Description	Get the operating channel number used for transmitting and receiving between RF modules. Uses 802.15.4 channel numbers. A value of "0" means the device has not joined a PAN and is not operating on any channel.
Execute	AT+OPCH?<CR>
Response	<value><CR> OK<CR>

7.3.5 AT+OPPANID or AT+OI

Description	Get the operating 16-bit PAN ID. If PAN ID is set specific value not 0s, operating PAN ID will equal designated PAN ID. A value of "FFFF" means the device is not joined a network.
Execute	AT+OPPANID?<CR>
Response	<value><CR> OK<CR>

7.3.6 AT+OPEPID or AT+OE

Description	Get the operating 64-bit extended PAN ID. A value of "FFFFFFFFFFFFFFFF" means the device is not joined a network.
Execute	AT+OPEPID?<CR>
Response	<value><CR> OK<CR>

7.3.7 AT+VERSION or AT+VR

Description	Get firmware version of the module. The firmware version returns a form of "HAvx.x".
Execute	AT+VERSION?<CR>
Response	<value><CR> OK<CR>

7.3.8 AT+PRODUCTNAME or AT+PN

Description	Get the product name. It can be used to distinguish among different hardware platforms.
Execute	AT+PRODUCTNAME?<CR>
Response	<value><CR> OK<CR>

7.4 Network Specific Parameters

7.4.1 AT+CHMASK or AT+CM

Description	Get/Set the channel mask to use. Bits set as 1 indicate that this particular channel can be used. Bits set as 0 indicate that this particular channel should not be used. For example, a channel mask value of 0x00000001 indicates that only channel 0 should be used. Valid channels range from 11 to 26 inclusive. (16 channels are available.) This translates to a channel mask value of "0x07FFF800".	
Execute	AT+CHMASK?<CR>	AT+CHMASK=<value><CR>
Response	<value><CR> OK<CR>	OK<CR> or ERROR<CR>
Default	07FFF800	
Range	00000800 - 07FFF800	

7.4.2 AT+PANID or AT+PI

Description	Get/Set the 16-bit PAN ID. If it is set to 0s at a coordinator, the coordinator will select a random 16-bit hexadecimal number as PAN ID. If it is set to 0s at a router/end-device, the router/end-device will try to join any existing network regardless of PAN ID.	
Execute	AT+PANID?<CR>	AT+PANID=<value><CR>
Response	<value><CR> OK<CR>	OK<CR> or ERROR<CR>
Default	0000	
Range	0000 – FFFF	

7.4.3 AT+EPID or AT+EI

Description	Get/Set the 64-bit extended PAN ID. If the node is a coordinator and the EPID is set to 0s, it will create new extended PAN ID using its 64-bit IEEE address as extended PAN ID. If the node is a router or end-device and the EPID is set to 0x, it will try to join any existing network regardless of extended PAN ID.	
Execute	AT+EPID?<CR>	AT+EPID=<value><CR>
Response	<value><CR> OK<CR>	OK<CR> or ERROR<CR>
Default	0000000000000000	
Range	0000000000000000 – FFFFFFFFFFFFFFFF	

7.4.4 AT+GROUPID or AT+GI

Description	Get/Set the 16-bit Group ID. It is used for multicast data reception.	
Execute	AT+GROUPID?<CR>	AT+GROUPID=<value><CR>

Response	<value><CR> OK<CR>	OK<CR> or ERROR<CR>
Default	0000	
Range	0000 – FFFF	

7.4.5 AT+POWER or AT+PW

Description	Get/Set the TX power at which the RF module transmits conducted power.	
Execute	AT+POWER?<CR>	AT+POWER=<value><CR>
Response	<value><CR> OK<CR>	OK<CR> or ERROR<CR>
Default	8	
Range	-43 – 8	

7.4.6 AT+STACK or AT+ZS

Description	Get/Set the ZigBee stack profile value. This value must be set the same on all devices that should join the same network. (0: Network specific, 1: ZigBee, 2: ZigBee Pro)	
Execute	AT+STACK?<CR>	AT+STACK=<value><CR>
Response	<value><CR> OK<CR>	OK<CR> or ERROR<CR>
Default	2	
Range	0 – 2	

* Default value changed 2 from 0

7.4.7 AT+NODENAME or AT+NN

Description	Get/Set the node name. It can be used to make a clear distinction role or functionality of local node from others.	
Execute	AT+NODENAME?<CR>	AT+NODENAME=<value><CR>
Response	<value><CR> OK<CR>	OK<CR> or ERROR<CR>
Default	ProBee-HAxx	
Range	Up to 16 characters	

7.5 Network Formation and Join

7.5.1 AT+ASCAN or AT+AS

Description	Perform a scanning for existing network. It can take up to 5 seconds. (<i>CAUTION: It is possible to cause a link error if a node is a parent of an end-device.</i>)	
Execute	AT+ASCAN<CR>	AT+ASCAN=<channel mask><CR>
Response	<channel> <PAN ID> <EPID> <joinable> <stack profile>	

	<i>List of the existing networks ...</i> OK<CR>
--	--

7.5.2 AT+ESCAN or AT+ES

Description	Perform a scanning for energy level of all channels. It can be used to avoid interference. It can take up to 5 seconds. The RSSI energy level ranges from approximately -100 to +127 in dBm. (<i>CAUTION: It is possible to cause a link error if a node is a parent of an end-device.</i>)	
Execute	AT+ESCAN<CR>	AT+ESCAN=<channel mask><CR>
Response	<channel> <RSSI > <i>List of the RSSI for each channel ...</i> OK<CR>	

7.5.3 AT+DSCAN or AT+DS

Description	Perform a scanning for existing nodes in the current network. A coordinator or router can have children nodes and they are presented by "CLDn". It can be possible to place some conditions such as scan duration, node type and node name in order. The information of local node is presented by "**". (<i>CAUTION: A ProBee-Z*10 with PTV1.2 or earlier cannot receive the response of AT+DSCAN from any ProBee-Z*10 with PTV1.3 or later. It cannot receive from any ProBee-Z*20, either. In this case, it is recommended to upgrade PTV1.2 to the latest version.</i>)	
Execute	AT+DSCAN<CR> or AT+DSCAN=<scan duration><CR> or AT+DSCAN=<scan duration>,<node type><CR> or AT+DSCAN=<scan duration>,<node type>,<node name><CR>	
Response	<node type> <IEEE address> <node ID> <version> <product name> <node name> <i>List of the existing nodes and information...</i> OK<CR>	
Range	Scan duration: 1 – 10 Node type: 0 – 4 (Zero indicates all node types.)	

7.5.4 AT+RSSI or AT+RS

Description	Get RSSI and LQI information respectively for the delivery of the recent packet across the last hop of the incoming route. The LQI value ranges from 0 to 255 with the maximum value representing the best possible link quality. The RSSI value ranges from approximately -100 to +127 with each value representing the energy level in dBm at the radio's receiver. The sender of the recent packet and
-------------	---

	the parent are also displayed.
Execute	AT+RSSI?<CR>
Response	Sender: <node ID>, Parent: FFFF, RSSI: <RSSI value>, LQI: <LQI value><CR> OK<CR>

7.5.5 AT+NODETYPE or AT+NT

Description	Get/Set the node type. (0: none, 1: coordinator, 2: router, 3: end-device, 4: sleepy end-device)	
Execute	AT+NODETYPE?<CR>	AT+NODETYPE=<value><CR>
Response	<value><CR> OK<CR>	OK<CR> or ERROR<CR>
Default	0	
Range	0 – 4	

7.5.6 AT+PERMIT or AT+PJ

Description	Permit other nodes to join the network. (0~254s, 255=continuance) An end-device cannot perform it.	
Execute	AT+PERMIT<CR>	AT+PERMIT=<value><CR>
Response	OK<CR>	
Range	0 – 255	

7.5.7 AT+LEAVE or AT+LV

Description	Leave the current network.
Execute	AT+LEAVE<CR>
Response	OK<CR>

7.6 End-device

7.6.1 AT+SLEEP or AT+SM

Description	Enter the sleep mode immediately if the node is a sleepy end-device.
Execute	AT+SLEEP<CR>
Response	OK<CR>

7.6.2 AT+PARENTLA or AT+PL

Description	Get the 64-bit IEEE address of the parent node.
Execute	AT+PARENTLA?<CR>
Response	<IEEE address><CR> OK<CR>

7.6.3 AT+PARENTSA or AT+PS

Description	Get the 16-bit Node ID of the parent node.
Execute	AT+PARENTSA?<CR>
Response	<node ID><CR> OK<CR>

7.6.4 AT+CHILDTABLE or AT+CT

Description	Get the child table composed of the end-devices.
Execute	AT+CHILDTABLE?<CR>
Response	<node type> <IEEE address> <node ID> <i>List of the child nodes...</i> OK<CR>

7.7 Data Transmission and Reception

7.7.1 AT+MAXPAYLOAD or AT+MP

Description	Get the maximum size of the payload that the Application Support sub-layer will accept. The size depends on the security level in use.
Execute	AT+MAXPAYLOAD?<CR>
Response	<value><CR> OK<CR>

7.8 Security

7.8.1 AT+SECURITY or AT+SE

Description	Get/Set the security status. (0: turning security off, 1: on) Every node must be under the same security level in the network.	
Execute	AT+SECURITY?<CR>	AT+SECURITY=<value><CR>
Response	<value><CR> OK<CR>	OK<CR> or ERROR<CR>
Default	1	
Range	0 – 1	

* Changed valued 1 from 0

7.8.2 AT+LINKKEY or AT+LK

Description	Get/Set the 128-bit link key. (0 or 0s: generate 128-bit random number)	
Execute	AT+LINKKEY?<CR>	AT+LINKKEY=<value><CR>
Response	<value><CR> OK<CR>	OK<CR> or ERROR<CR>
Default	5A6967426565416C6C69616E63653039	

7.8.3 AT+NWKKEY or AT+NK

Description	Get/Set the 128-bit network key. (0 or 0s: generate random 128-bit number)	
Execute	AT+NWKKEY?<CR>	AT+NWKKEY=<value><CR>
Response	<value><CR> OK<CR>	OK<CR> or ERROR<CR>
Default	FFFFFFFFFFFFFFFFFFFFFFFFFFFFFFFF	

7.8.4 AT+UPDATEKEY or AT+UK

Description	Update the network key with a new generated key. (possible only for coordinator) It is applied after 30s later because sending too quickly may cause a sleepy end-device to miss the alternate encryption key and only get the switch key message, which means it will be unable to change to the new network key.	
Execute	AT+UPDATEKEY<CR>	
Response	OK<CR> or ERROR<CR>	

7.9 UART**7.9.1 AT+BAUDRATE or AT+UB**

Description	Get/Set the serial port speed for communication between the module serial port and host.	
Execute	AT+BAUDRATE?<CR>	AT+BAUDRATE=<value><CR>
Response	<value><CR> OK<CR>	OK<CR> or ERROR<CR>
Default	9600	
Range	300 – 230400	

7.9.2 AT+DATABIT or AT+UD

Description	Get/Set the serial data bit setting on the module.	
Execute	AT+DATABIT?<CR>	AT+DATABIT=<value><CR>
Response	<value><CR> OK<CR>	OK<CR> or ERROR<CR>
Default	8	
Range	7 – 8	

7.9.3 AT+PARITY or AT+UP

Description	Get/Set the serial parity setting on the module.	
Execute	AT+PARITY?<CR>	AT+PARITY=<value><CR>
Response	<value><CR> OK<CR>	OK<CR> or ERROR<CR>

Default	0
Range	0 – 2

7.9.4 AT+STOPBIT or AT+US

Description	Get/Set the serial stop bit setting on the module.	
Execute	AT+STOPBIT?<CR>	AT+STOPBIT=<value><CR>
Response	<value><CR> OK<CR>	OK<CR> or ERROR<CR>
Default	1	
Range	1 – 2	

7.9.5 AT+FLOWCTRL or AT+UF

Description	Get/Set flow control status. (0: none, 1: software, 2: hardware flow control)	
Execute	AT+FLOWCTRL?<CR>	AT+FLOWCTRL=<value><CR>
Response	<value><CR> OK<CR>	OK<CR> or ERROR<CR>
Default	0	
Range	0 – 2	

7.10 GPIO

7.10.1 AT+GPIO or AT+IO

Description	Get/Set the configuration status of GPIO individually or all at once. Only GPIO9-14 can be set 0-5, others are available 0-3 and 5.	
Execute	AT+GPIO?<CR> or AT+GPIO<number>?<CR>	AT+GPIO=<values><CR> or AT+GPIO<number>=<value><CR>
Response	<value><CR> OK<CR>	OK<CR> or ERROR<CR>
Default	5555500000000055	
Range	GPIO9-14: 0-6, the others: 0-3 and 5-6 0 Disabled (unmonitored digital input) 1 Digital input, monitored 2 Digital output, default low 3 Digital output, default high 4 Analog input, single ended (only valid for GPIO9~14) 5 Reserved for pin-specific alternate functionalities 6 Home Automation GPIO (only valid for ProBeeHADL and ProBeeHAOL)	

7.10.2 AT+DIO

Description	Get/Set the digital IO value individually or all at once. All GPIO pins can be used
-------------	---

	as digital IO and it is only possible to set 0 or 1. If there are some pins used analog input, they are displayed by “*”.	
Execute	AT+DIO?<CR> or AT+DIO<number>?<CR>	AT+DIO=<values><CR> or AT+DIO<number>=<value><CR>
Response	<value><CR> OK<CR>	OK<CR> or ERROR<CR>
Default	0000000000000000	
Range	0000000000000000 – 1111111111111111	

7.10.3 AT+AI

Description	Get the analog input value individually or all at once. GPIO9~14 are possible to set ADC and it's read only. If there are some pins used digital IO, they are displayed by “****”.	
Execute	AT+AI?<CR>	AT+AI<number>?<CR>
Response	<value>,<value>,<value>,<value><CR> OK<CR>	<value><CR> OK<CR>

7.10.4 AT+SOURCELA or AT+SL

Description	Get/Set the 64-bit source IEEE address for GPIO remote control. It is possible to limit on the implementation of this functionality by setting specific address. If set to default value, “FFFFFFFFFFFFFFFF”, the node allows that any node can control the GPIO status.	
Execute	AT+SOURCELA?<CR>	AT+SOURCELA=<value><CR>
Response	<value><CR> OK<CR>	OK<CR> or ERROR<CR>
Default	FFFFFFFFFFFFFFFF	
Range	0000000000000000 – FFFFFFFFFFFFFFFFFF	

7.11 Firmware Upload and Help

7.11.1 AT+BOOTLOAD or AT+BL

Description	Start bootloader to upload firmware. (blank: local, 1: passthru) The device leaves the AT command line and enters the bootloader menu for uploading new ProBee firmware. There's no restrict to use local upload but a sleepy end-device cannot upload to remote node over the air. The current UART should be set 115200bps, 8 data bits, no parity, 1 stop bit and none flow control.	
Execute	AT+BOOTLOAD<CR>	AT+BOOTLOAD=<number>,<IEEE><CR>
Response	<i>Bootloader menu</i> ... Serial upload complete	Please start .ebl upload image ...<CR> or Start cloning ...<CR> <i>Bootloader menu</i>

		...
		Bootload Complete!

7.11.2 AT+HELP or AT+HP

Description	Show all the available commands
Execute	AT+HELP<CR>
Response	Available AT Commands ... OK<CR>

7.12 Home Automation Commands

7.12.1 AT+ATTR or AT+AR

Description	Show all attributes of local node.
Execute	AT+ATTR?<CR> AT+ATTR=<clusterID><CR>
Response	clus attr data(cluster name) <clusterID> <attributeID> <data>(<clusterName>) ... OK<CR>

7.12.2 AT+INFO or AT+IF

Description	Show home automation device information
Execute	AT+INFO?<CR>
Response	Security Level: <security level>, Security Profile: HA End-point count: <endpointCount> End-point No.<endpoint>: ProfileID-<profileID>, DeviceID-<deviceID> Client-side cluster: <clusterID>(<clusterName>) Server-side cluster: <clusterID>(<clusterName>) ... OK<CR>

7.12.3 AT+DEST or AT+DE

Description	Set address of destination node. This address will be used in AT+CREAD, AT+CWRITE, AT+CCMD, AT+SCMD and other HA commands.
Execute	AT+DEST=<nodeID>,<endpoint><CR>
Response	OK<CR> or ERROR<CR>

7.12.4 AT+SREAD or AT+SR

Description	Read attribute from local node. (server-side command)
Execute	AT+SREAD=<clusterID>,<attributeID><CR>

Response	<attribute value> OK<CR> or ERROR<CR>
----------	--

7.12.5 AT+CREAD or AT+CR

Description	Read attribute from remote node. (client-side command)
Execute	AT+DEST=<address>,<endpoint><CR> AT+CREAD=<clusterID>,<attributeID><CR>
Response	<attribute value> OK<CR> or ERROR<CR>

7.12.6 AT+SWRITE or AT+SW

Description	Write attribute to local node. (server-side command)
Execute	AT+SWRITE=<clusterID>,<attributeID>,<value><CR>
Response	OK<CR> or ERROR<CR>

7.12.7 AT+CWRITE or AT+CW

Description	Write attribute to remote node. (client-side command)
Execute	AT+DEST=<address>,<endpoint><CR> AT+CWRITE=<clusterID>,<attributeID>,<value><CR>
Response	OK<CR> or ERROR<CR>

7.12.8 AT+SCMD or AT+SC

Description	Send server-side command message to destination node. (server-side command)
Execute	AT+DEST=<address>,<endpoint><CR> AT+SCMD=<clusterID>,<commandID><CR>
Response	OK<CR> or ERROR<CR>

7.12.9 AT+CCMD or AT+CC

Description	Send client-side command message to destination node. (client-side command)
Execute	AT+DEST=<address>,<endpoint><CR> AT+CCMD=<clusterID>,<commandID><CR>
Response	OK<CR> or ERROR<CR>

7.12.10 AT+FACTORYRESET or AT+FR

Description	Send 'Factory Reset' command(Basic cluster) to destination node. (client-side command)
Execute	AT+DEST=<address>,<endpoint><CR> AT+FACTORYRESET?<CR>

Response	OK<CR> or ERROR<CR>
----------	---------------------

7.12.11 AT+IDENTIFY or AT+II

Description	Send 'Identify' command(Identify cluster) to destination node. (client-side command)
Execute	AT+DEST=<address>,<endpoint><CR> AT+IDENTIFY=<time><CR>
Response	OK<CR> or ERROR<CR>

7.12.12 AT+IDENQUERY or AT+IQ

Description	Send 'Identify Query' command(Identify cluster) to destination node. (client-side command)
Execute	AT+DEST=<address>,<endpoint><CR> AT+IDENQUERY?<CR>
Response	OK<CR> or ERROR<CR>

7.13 ProBeeHACI (Combined Interface) Profile Commands

7.13.1 AT+LOCK or AT+LK

Description	Send 'Lock' command(Door Lock cluster) to destination node. (client-side command)
Execute	AT+DEST=<address>,<endpoint><CR> AT+LOCK?<CR>
Response	OK<CR> or ERROR<CR>

7.13.2 AT+UNLOCK or AT+UL

Description	Send 'Unlock' command(Door Lock cluster) to destination node. (client-side command)
Execute	AT+DEST=<address>,<endpoint><CR> AT+UNLOCK?<CR>
Response	OK<CR> or ERROR<CR>

7.13.3 AT+ON

Description	Send 'On' command(On/Off cluster) to destination node. (client-side command)
Execute	AT+DEST=<address>,<endpoint><CR> AT+ON?<CR>
Response	OK<CR> or ERROR<CR>

7.13.4 AT+OFF or AT+OF

Description	Send 'On' command(On/Off cluster) to destination node. (client-side command)
-------------	--

Execute	AT+DEST=<address>,<endpoint><CR> AT+OFF?<CR>
Response	OK<CR> or ERROR<CR>

7.13.5 AT+TOGGLE or AT+TG

Description	Send 'Toggle' command(On/Off cluster) to destination node. (client-side command)
Execute	AT+DEST=<address>,<endpoint><CR> AT+TOGGLE?<CR>
Response	OK<CR> or ERROR<CR>

7.13.6 AT+MVTOLV or AT+ML

Description	Send 'Move-to-level' command(Level Control cluster) to destination node. (client-side command)
Execute	AT+DEST=<address>,<endpoint><CR> AT+MVTOLV=<value><CR>
Response	OK<CR> or ERROR<CR>

7.14 ProBeeHADL (Door Lock) Profile Commands

7.14.1 AT+RLOCK or AT+RLK

Description	Send 'Lock Response' command(Door Lock cluster) to destination node. (server-side command)
Execute	AT+RLOCK?<CR>
Response	OK<CR> or ERROR<CR>

7.14.2 AT+RUNLOCK or AT+RUK

Description	Send 'Unlock Response' command(Door Lock cluster) to destination node. (server-side command)
Execute	AT+RUNLOCK?<CR>
Response	OK<CR> or ERROR<CR>

8 S-Registers

Register number	Descriptions
11	Display incoming message in command mode
12	Display command echo
13	Display command responses
14	Manage LED status
22	Permit joining timeout
23	TX power mode
41	GPIO pull-up
42	GPIO monitoring period
43	GPIO monitoring node
44	GPIO change detection sampling
45	GPIO remote control
51	Poll timeout for a parent node
52	Poll period for a sleepy end-device
53	Sleep duration
54	Standby timeout
55	Rejoin timeout
56	Poll period for an end-device
71	Enable Frequency agility

8.1 Display Options

8.1.1 S11

Description	Get/Set the display mode. It determines to display incoming message in command mode.	
Execute	ATS11?<CR>	ATS11=<value><CR>
Response	<value><CR> OK<CR>	OK<CR>
Default	1	
Range	0 - 1	

8.1.2 S12

Description	Get/Set the command echo mode.	
Execute	ATS12?<CR>	ATS12=<value><CR>
Response	<value><CR> OK<CR>	OK<CR>
Default	1	
Range	0 – 1	

8.1.3 S13

Description	Get/Set the command responses mode.	
Execute	ATS13?<CR>	ATS13=<value><CR>
Response	<value><CR> OK<CR>	OK<CR>
Default	1	
Range	0 - 1	

8.1.4 S14

Description	<p>Get/Set the LED mode. It causes the LED operation if the device is ZE20S set GPIO15, 16 to specific functionality.</p> <p>0: LEDs are always OFF regardless of configuration or status. 1: LEDs are OFF when the node is under sleep status. 2: LEDs always operate by the case.</p>	
Execute	ATS14?<CR>	ATS14=<value><CR>
Response	<value><CR> OK<CR>	OK<CR>
Default	1	
Range	0 - 2	

8.2 Network Settings**8.2.1 S22**

Description	Get/Set the timeout to permit joining. It determines the time in seconds that the device will allow other devices to join to it when it starts network but an end-device cannot perform it. If set to 255, the device will always permit joining.	
Execute	ATS22?<CR>	ATS22=<value><CR>
Response	<value><CR> OK<CR>	OK<CR>
Default	255	
Range	0 - 255	

8.2.2 S23

Description	Get/Set the power boost mode of the module. If enabled, boost mode improves sensitivity and increases output power, improving the link margin and range.	
Execute	ATS23?<CR>	ATS23=<value><CR>
Response	<value><CR> OK<CR>	OK<CR>

Default	0
Range	0 – 1

8.3 GPIO

8.3.1 S41

Description	Get/Set the GPIO pull up/down option. If GPIOs are set to DI(Digital Input), it is possible to pull-up or pull-down with this value. Pull-down = 0, Pull-up = 1.	
Execute	ATS41?<CR>	ATS41=<value><CR>
Response	<value><CR> OK<CR>	OK<CR>
Default	0	
Range	0 - 1	

8.3.2 S42

Description	Get/Set the GPIO monitoring period in seconds. If it is enabled, a node sends GPIO values to a remote node based on preconfigured destination IEEE address periodically and it is possible to monitor the GPIO status at the remote node. A remote node can also be the sink node according to GPIO monitoring node (S43). If set to 0, GPIO monitoring is disabled.	
Execute	ATS42?<CR>	ATS42=<value><CR>
Response	<value><CR> OK<CR>	OK<CR>
Default	0	
Range	0 – 10000	

8.3.3 S43

Description	Get/Set the GPIO monitoring node. If S43 is 0, the monitoring node is selected by AT+DESTLA or AT+DL command. If S43 is 1, the sink node is set as the monitoring node.	
Execute	ATS43?<CR>	ATS43=<value><CR>
Response	<value><CR> OK<CR>	OK<CR>
Default	0	
Range	0 – 10000	

8.3.4 S44

Description	Get/Set the GPIO change detection sampling mode. If it is enabled, a node sends GPIO values to a remote node based on preconfigured destination IEEE address immediately when the status of GPIO changes. A remote node can also be the sink	
-------------	--	--

	node according to GPIO monitoring node (S43). If set to 0, GPIO change detection sampling is disabled.	
Execute	ATS44?<CR>	ATS44=<value><CR>
Response	<value><CR> OK<CR>	OK<CR>
Default	0	
Range	0 – 1	

8.3.5 S45

Description	Get/Set the GPIO remote control mode. If any GPIO pin is set to digital input, a node can control the I/O status of a remote node if the I/O pin of the remote node is set to digital output. It is possible to use when GPIO monitoring is enabled (GPIO monitoring period, S42 > 0) or GPIO change detection sampling is enabled.(GPIO change detection sampling mode, S44 = 1)	
Execute	ATS45?<CR>	ATS45=<value><CR>
Response	<value><CR> OK<CR>	OK<CR>
Default	0	
Range	0 – 1	

8.4 End-Device

8.4.1 S51

Description	Get/Set the poll timeout for a parent node in seconds. If an end-device or a sleepy end-device does not send a poll request to its parent coordinator or router within the poll timeout, the end-device is removed from the child table.	
Execute	ATS51?<CR>	ATS51=<value><CR>
Response	<value><CR> OK<CR>	OK<CR>
Default	60	
Range	0 – 4177920	

8.4.2 S52

Description	Get/Set the sleepy end-device poll period in milliseconds. Adaptive polling may allow the sleepy end-device to poll more rapidly for a short time when receiving RF data.	
Execute	ATS52?<CR>	ATS52=<value><CR>
Response	<value><CR> OK<CR>	OK<CR>
Default	100	
Range	0 - 10000	

8.4.3 S53

Description	Get/Set the sleep duration in quarter seconds. An end-device sleeps for this time and turns off radio every sleep cycle. If a node sleeps over poll timeout of parent node, the device will be removed from the child table.	
Execute	ATS53?<CR>	ATS53=<value><CR>
Response	<value><CR> OK<CR>	OK<CR>
Default	8	
Range	0 – 16711680	

8.4.4 S54

Description	Get/Set the standby timeout in seconds. When an end-device wakes up and polls with the parent node, the node will wait for another data from the ZigBee network or from the serial port for S54 before it goes to sleep mode again. If any serial or RF data is sent or received, the timer will reset and wait for next again.	
Execute	ATS54?<CR>	ATS54=<value><CR>
Response	<value><CR> OK<CR>	OK<CR>
Default	5	
Range	0 – 10000	

8.4.5 S55

Description	Get/Set the rejoin timeout. If it is enabled, an end-device tries to rejoin the current network when contact with the network has been lost for setting value in seconds. The most common usage case is when an end-device can no longer communicate with its parent and wishes to find a new one. A value of zero, don't try to rejoin.	
Execute	ATS55?<CR>	ATS55=<value><CR>
Response	<value><CR> OK<CR>	OK<CR>
Default	10	
Range	0 – 10000	

8.4.6 S56

Description	Get/Set the end-device poll period in seconds. Adaptive polling may allow the end-device to poll more rapidly for a short time when receiving RF data.	
Execute	ATS56?<CR>	ATS56=<value><CR>
Response	<value><CR> OK<CR>	OK<CR>

Default	5
Range	0 - 10000

8.5 Frequency Agility

8.5.1 S71

Description	Get/Set the Frequency agility function. If it is enabled in coordinator mode, node will automatically shift operating channel to one of channel masks when its unicasts fail more than threshold.	
Execute	ATS71?<CR>	ATS71=<value><CR>
Response	<value><CR> OK<CR>	OK<CR>
Default	0	
Range	0 – 1	

9 HA Command Example

9.1 Cluster Command for Binding (ProBeeHACI - ProBeeHADL)

Each Smart Energy node can communicate with the other by cluster command. A cluster consists of server-side cluster and client-side cluster, and both of them have their own commands. If a Home Automation node has server-side or client-side cluster, the node can send cluster command to other node that has the other side cluster. Here is an example for sending cluster command.

Example) Check ProBeeHADL node and set as coordinator.

```
AT+VERSION<CR>           # Get ProBee HA Version
HADLv1.8                 # ProBeeHADL - Door Lock
OK                        # Response
AT+NODETYPE=1           # Set node type as the coordinator
OK                        # Response
AT+PANID=1234           # Set PAN ID as 0x1234
OK                        # Response
ATZ                       # Reset and apply all settings
OK                        # Response
```

Example) Check ProBeeHACI node and set as router.

```
AT+VERSION<CR>           # Get ProBee HA Version
HACIv1.8                 # ProBeeHACI - Combined Interface
OK                        # Response
AT+NODETYPE=2           # Set node type as the router
OK                        # Response
AT+PANID=1234           # Set same PAN ID as coordinator
OK                        # Response
ATZ                       # Reset and apply all settings
OK                        # Response
```

Make a network by setting ProBeeHADL node to coordinator and setting ProBeeHACI node to router. Then you can make ProBeeHACI communicate with ProBeeHADL through cluster binding.

Example) Send the 'Lock' command in Door Lock cluster from ProBeeHACI node.

```
AT+DEST=0000,01<CR>     # Set Destination node to coordinator
                        # Coordinator is now ProBeeHADL
AT+LOCK<CR>             # Send 'Lock' Command to
```

```

                                # ProBeeHADL Door Lock Cluster (Server)
OK                                # Response

```

Then ProBeeHADL node receives the Lock command messages as below:

```

+0000|HA_SERVER_COMMAND|0101|00    # Received 'Lock' Command from
                                # ProBeeHACI
+0000|HA_GLOBAL_COMMAND|0101|0B    # Received 'ACK' Command from
                                # ProBeeHACI

```

9.2 Cluster Command for Binding (ProBeeHACI - ProBeeHAOL)

Update ProBeeHACI firmwares to node and ProBeeHAOL firmware to another node for testing cluster binding.

Example) Check ProBeeHAOL node and set as coordinator.

```

AT+VERSION<CR>                    # Get ProBee HA Version
HAOLv1.8                           # ProBeeHAOL - Dimmable On/Off Light
OK                                  # Response
AT+NODETYPE=1                       # Set node type as the coordinator
OK                                  # Response
AT+PANID=5678                       # Set PAN ID as 0x5678
OK                                  # Response
ATZ                                  # Reset and apply all settings
OK                                  # Response

```

Example) Check ProBeeHACI node and set as router.

```

AT+VERSION<CR>                    # Get ProBee HA Version
HACIv1.8                           # ProBeeHACI - Combined Interface
OK                                  # Response
AT+NODETYPE=2                       # Set node type as the router
OK                                  # Response
AT+PANID=5678                       # Set same PAN ID as the coordinator
OK                                  # Response
ATZ                                  # Reset and apply all settings
OK                                  # Response

```

Make a network by setting ProBeeHAOL node to coordinator and setting ProBeeHACI node to router. Then you can make ProBeeHACI communicate with ProBeeHAOL through cluster binding.

Example) Send the 'On' command in On/Off cluster from ProBeeHACI node.

```

AT+DEST=0000,01<CR>          # Set Destination node to coordinator
                                # Coordinator is now ProBeeHAOL
AT+CREAD=0006,0000<CR>      # Read On/Off(0x0006) Cluster Attribute
00                             # Attribute 0x0000's value is 00 (Off)
OK                             # Response
AT+ON<CR>                     # Send 'On' Command to
                                # ProBeeHAOL On/Off Cluster
OK                             # Response
AT+CREAD=0006,0000<CR>      # Read On/Off(0x0006) Cluster Attribute
01                             # Attribute(0x0000) value is changed(On)
OK                             # Response

```

Example) Send the 'Move-to-Level' command in Level Control cluster from ProBeeHACI node.

```

AT+DEST=0000,01<CR>          # Set Destination node to coordinator
                                # Coordinator is now ProBeeHAOL
AT+CREAD=0008,0000<CR>      # Read Level Control(0x0008) Cluster
08                             # Attribute 0x0000's value is 8(0x08)
OK                             # Response
AT+MVTOLV=25<CR>            # Send 'Move-to-Level' Command to
                                # ProBeeHAOL Level Control Cluster
OK                             # Response
AT+CREAD=0008,0000<CR>      # Read On/Off(0x0008) Cluster Attribute
19                             # Attribute(0x0000) value is changed
                                # to 25(0x19)
OK                             # Response

```

9.3 Showing Attribute Information

Each Home Automation node has its own attributes. User can see their information by running the AT command as below:

Example) Show attributes of ProBeeHACI

```

AT+ATTR<CR>                  # Show attributes of current device
ENDPOINT 01
clus|attr|data(clusterName)

```

1	# Locked
OK	# Response

Following table shows what means attribute value in example.

Table 9-1 Door Lock cluster's attribute (in HA specification document)

Attribute Identifier	Description	Type	Default
0x0000	Lock State 0x00: Not fully locked 0x01: Locked 0x02: Unlocked	Enum8	0
0x0001	Lock Type 0x00: dead bolt 0x01: magnetic 0x02: other 0x03: 0xff reserved	Enum8	0
0x0002	Actuator Enabled	Boolean	0
0x0003	Door State 0x00: Open 0x01: Closed 0x02: Error (Jammed) 0x03: Error (Forced Open) 0x04: Error (Unspecified) 0x05: 0xff reserved	Enum8	0
0x0004	Number of Door Open Events	Int32u	0
0x0005	Number of Door Closed Events	Int32u	0
0x0006	Number of minutes door has been open since this last time it transitioned from close to open	Int16u	0

9.5 Writing Attribute

User can write attribute to local node or remote node by running the AT command as below:

- AT+SWRITE can be used for writing attribute to local node.
- AT+CWRITE can be used for writing attribute to remote node.
- User should set destination address by command AT+DEST before running AT+CWRITE.
- Destination node must implement corresponding attribute and cluster.

Example) Write attribute to local node.

```
AT+SWRITE=0101,0003,01<CR> # Write device attribute
                                # Door Lock cluster(0x0101),
                                # Door state attribute(0x0003)
                                # Set to 0x0001 (Closed)
OK                               # Response
```

Example) Write attribute to remote node.

```
AT+DEST=3A51,01<CR> # Set destination node address
OK                   # Response
AT+CWRITE=0101,0003,01<CR> # Write destination's attribute
                                # Door Lock cluster(0x0101),
                                # Door state attribute(0x0003)
                                # Set to 0x0001 (Closed)
OK                   # Response
```

9.6 Sending HA Command

HA Clusters have attributes and commands, and cluster command can be committed by AT command.

Example)

There are two end nodes which makes up HA network. Coordinator is ProBeeHADL device which implements Door Lock Server Cluster. Router is ProBeeHACI device which implements Door Lock Cluster. ProBeeHACI device sends AT+LOCK command to ProBeeHADL device as below:

```
AT+DEST=0000,01<CR> # Set destination node address
OK                   # Response
AT+SREAD=0101,0000 # Read destination's attribute
                                # Door Lock cluster(0x0101),
                                # Lock state attribute(0x0000)
2                    # Unlocked
OK                   # Response
AT+LOCK<CR>         # Door Lock command
OK                   # Response
AT+SREAD=0101,0000<CR> # Read destination's attribute
                                # Door Lock cluster(0x0101),
                                # Lock state attribute(0x0000)
1                    # Locked
```

```
OK # Response
```

You can also send the identical command by using the AT+CCMD instead of the AT+LOCK command as below:

```
AT+DEST=0000,01<CR> # Set destination node address
OK # Response
AT+CCMD=0101,10<CR> # Send 'Lock Response' command
                        # Door Lock cluster(0x0101)
                        # Lock Response command(0x10)
OK # Response
```

ProBeeHAxx firmware does not support all the commands in clusters. The AT+CCMD command can be used instead of not all the commands but a few commands in clusters.

9.7 Receive HA Command

If your node receives HA Device Command, you can see following message.

```
+0000|HA_CLIENT_COMMAND|0101|00 # Received message
                                # 0x0101 (Door Lock cluster)
                                # 0x00 (Lock command)
```

* You can see Door Lock cluster command list in Chapter 6.4.2

9.8 Testing HA GPIO

HA GPIO can assign your GPIO pins to state attribute for monitoring. In ProBeeHAOL device, HA GPIO pins are assigned to On/Off cluster, and in ProBeeHADL device, HA GPIO pins are assigned to Door Lock cluster. You can see more information about HA GPIO in Chapter 4.2.

Example) Coordinator node is ProBeeHAOL and end device is ProBeeHACI.

```
# ProBeeHAOL node
AT+GPIO=66666666666666666666666666666666<CR> # Set all pins to HA GPIO
OK # Response
```

Send HA commands to ProBeeHAOL coordinator from ProBeeHACI End Device for control HA GPIO as below:

```
# ProBeeHACI node
AT+DEST=0000,01<CR> # Set destination node to
OK # Coordinator (ProBeeHAOL)
AT+OFF<CR> # Send 'Off' command
OK # Now HA GPIO pins changed to low
```

```
AT+ON<CR>           # Send 'On' command  
OK                   # Now HA GPIO pins changed to high
```

10 Pin Assignments

NO	Pin Assignment
1	GND
2	PC_5/FACTORY_RST
3	PC_6/GPIO0
4	PC_7/DTR/GPIO1
5	PA_7/DSR/GPIO2
6	PB_3/CTS/GPIO3
7	PB_4/RTS/GPIO4
8	PA_0/MOSI/GPIO5
9	PA_1/MISO/GPIO6
10	PA_2/SCLK/GPIO7
11	PA_3/nSSEL/GPIO8
12	VCC
13	GND

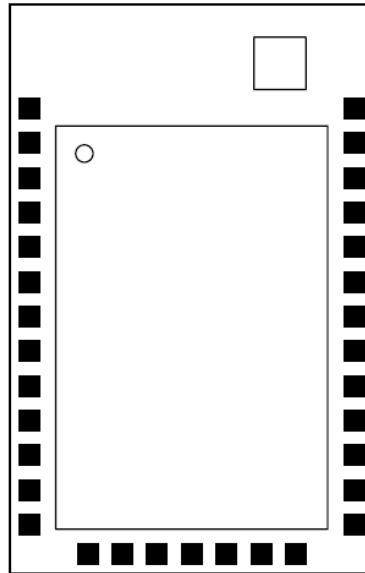

Pin Assignment	NO
GND	33
PB_5/ADC0/GPIO9	32
PB_6/ADC1/GPIO10	31
PB_7/ADC2/GPIO11	30
PC_1/ADC3/GPIO12	29
PA_4/ADC4/GPIO13	28
PA_5/ADC5/GPIO14	27
PB_1/TXD	26
PB_2/RXD	25
PB_0/GPIO15	24
PA_6/GPIO16	23
/RESET	22
GND	21

14	VCC
15	JTCK
16	PC_2/JTDO
17	PC_3/JTDI
18	PC_4/JTMS
19	PC_0/JRST
20	GND

Figure 10-1 Pin Assignments

Table 10-1 Pin Assignments Table

Pin	NAME	Default Function	Direction	Description
1	GND	-	-	Ground
2	Factory Reset	Factory Reset	IN	Digital I/O, Factory reset input, Active low
3	GPIO_0	Permit Joining	IN/OUT	Digital I/O, Permit joining input
4	GPIO_1	UART_DTR	IN/OUT	Digital I/O, UART_DTR
5	GPIO_2	UART_DSR	IN/OUT	Digital I/O, UART_DSR
6	GPIO_3	UART_CTS	IN/OUT	Digital I/O, UART_CTS
7	GPIO_4	UART_RTS	IN/OUT	Digital I/O, UART_RTS
8	GPIO_5	DIO_5	IN/OUT	Digital I/O
9	GPIO_6	DIO_6	IN/OUT	Digital I/O
10	GPIO_7	DIO_7	IN/OUT	Digital I/O
11	GPIO_8	DIO_8	IN/OUT	Digital I/O
12	VCC	-	IN	Power supply, 3.3V
13	GND	-	-	Ground
14	VCC	-	-	Power supply, 3.3V
15	JTCK	-	IN	JTAG clock input from debugger
16	JTDO	-	OUT	JTAG data output to debugger
17	JTDI	-	IN	JTAG data input from debugger
18	JTMS	-	IN	JTAG mode select from debugger
19	JRST	-	IN	JTAG reset input from debugger
20	GND	-	-	Ground
21	GND	-	-	Ground
22	/RESET	-	IN	H/W_/Reset, Active low
23	GPIO_16	Status LED	IN/OUT	Digital I/O, Status LED
24	GPIO_15	Power LED	IN/OUT	Digital I/O, Power LED
25	UART_RXD	UART_RXD	IN	UART Data Input
26	UART_TXD	UART_TXD	OUT	UART Data Output
27	GPIO_14	DIO_14	IN/OUT	Digital I/O / ADC_5
28	GPIO_13	DIO_13	IN/OUT	Digital I/O / ADC_4
29	GPIO_12	DIO_12	IN/OUT	Digital I/O / ADC_3
30	GPIO_11	DIO_11	IN/OUT	Digital I/O / ADC_2
31	GPIO_10	DIO_10	IN/OUT	Digital I/O / ADC_1
32	GPIO_9	DIO_9	IN/OUT	Digital I/O / ADC_0
33	GND	-	-	Ground

11 Connections

11.1 Serial Port Pin Outs

ProBee-ZE20S is a DCE device compatible with the RS232 standard, a DB9 female interface.

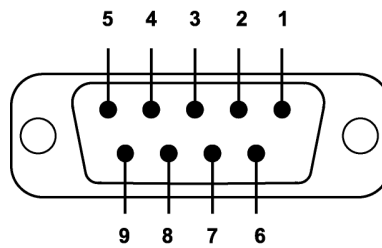

Figure 11-1 Pin layout of the DB-9 female connector

Table 11-1 Pin assignment of the DB-9 female connector

Pin #	Signal	Direction	Description
1	-	-	-
2	TxD	Output	Transmitted Data
3	RxD	Input	Received Data
4	DSR	Input	Data set ready
5	GND	-	Signal Ground
6	DTR	Output	Data terminal ready
7	CTS	Input	Clear to Send
8	RTS	Output	Ready to send
9	VCC	Input	(5V ~ 12V)

11.2 Serial Wiring Diagram

11.2.1 To Host with DTE Interface

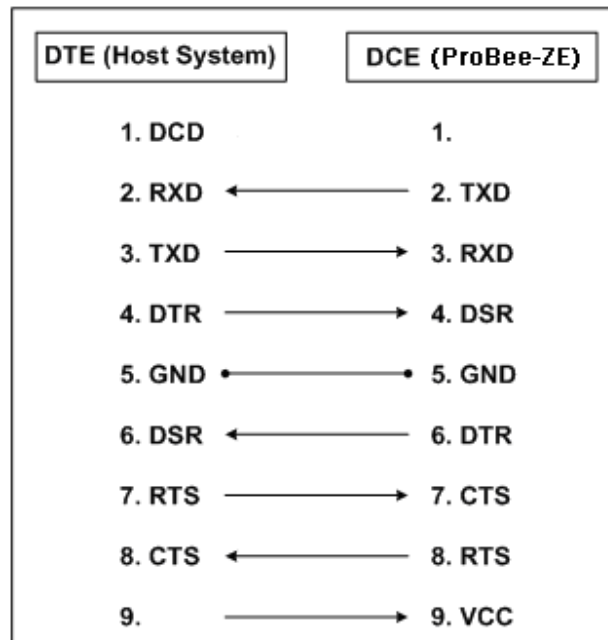

11.2.2 To Host with DCE Interface

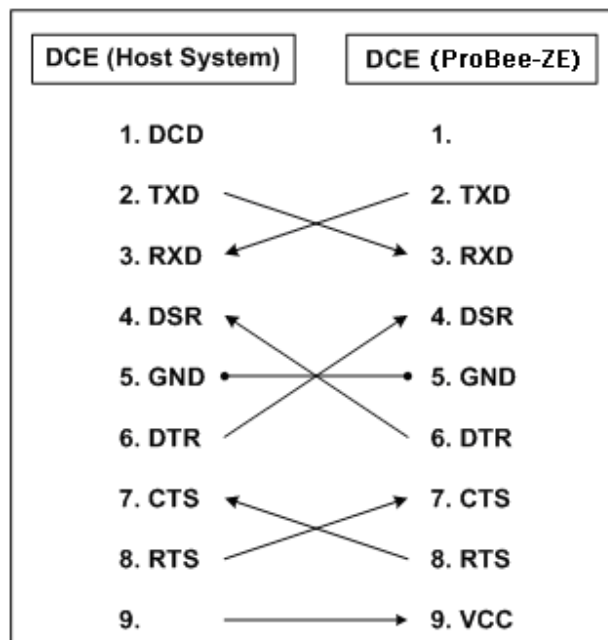

12 Mechanical Drawings

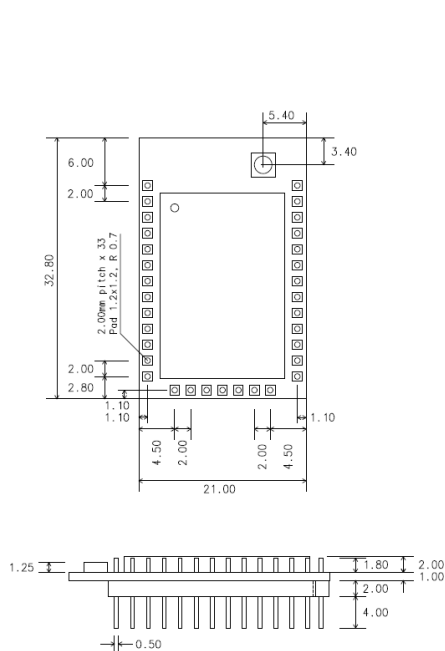

Figure 12-1 ProBee-ZE20SDU

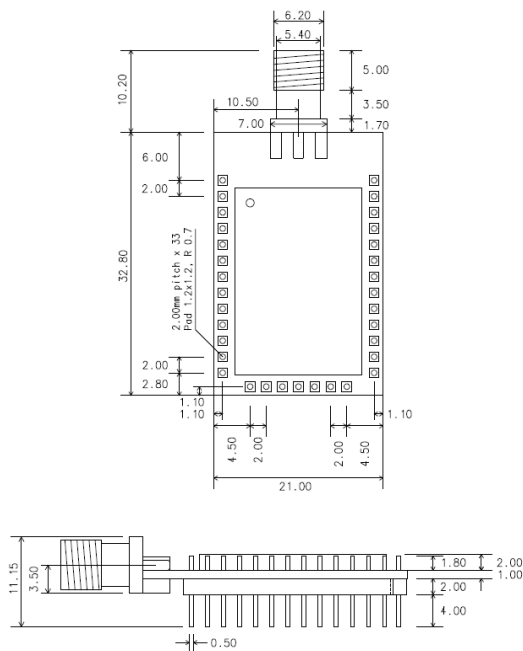

Figure 12-2 ProBee-ZE20SDS

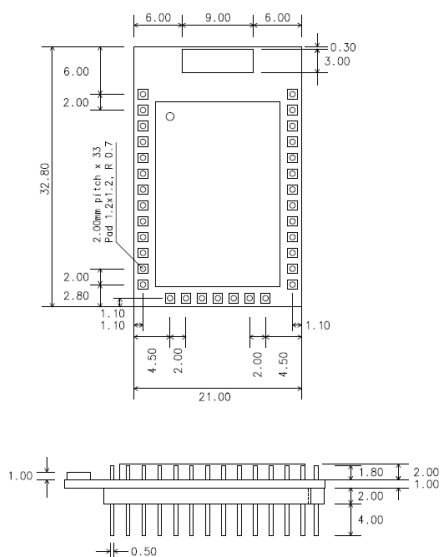

Figure 12-3 ProBee-ZE20SDC

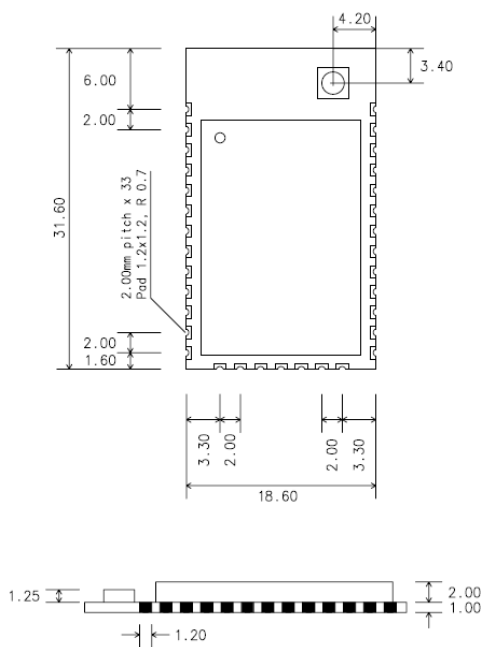

Figure 12-4 ProBee-ZE20SSU

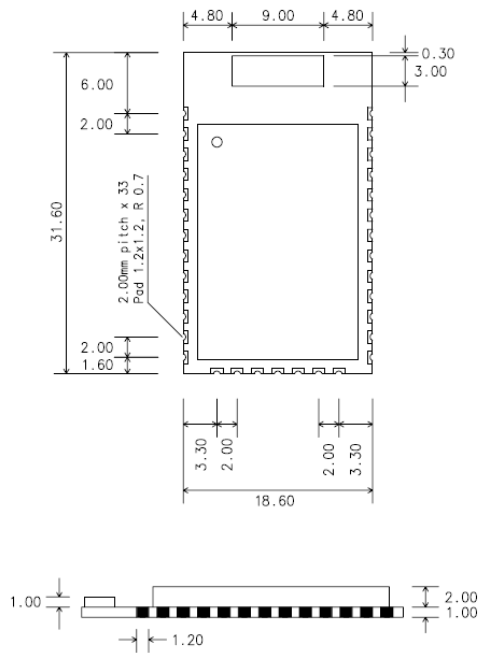

Figure 12-5 ProBee-ZE20SSC

13 Warranty

13.1 GENERAL WARRANTY POLICY

Sena Technologies, Inc. (hereinafter referred to as SENA) warrants that the Product shall conform to and perform in accordance with published technical specifications and the accompanying written materials, and shall be free of defects in materials and workmanship, for the period of time herein indicated, such warranty period commencing upon receipt of the Product.

This warranty is limited to the repair and/or replacement, at SENA's discretion, of defective or non-conforming Product, and SENA shall not be responsible for the failure of the Product to perform specified functions, or any other non-conformance caused by or attributable to: (a) any misapplication or misuse of the Product; (b) failure of Customer to adhere to any of SENA's specifications or instructions; (c) neglect of, abuse of, or accident to, the Product; or (d) any associated or complementary equipment or software not furnished by SENA.

Limited warranty service may be obtained by delivering the Product to SENA or to the international distributor it was purchased through and providing proof of purchase or receipt date. Customer agrees to insure the Product or assume the risk of loss or damage in transit, to prepay shipping charges to SENA, and to use the original shipping container or equivalent.

13.2 LIMITATION OF LIABILITY

EXCEPT AS EXPRESSLY PROVIDED HEREIN, SENA MAKES NO WARRANTY OF ANY KIND, EXPRESSED OR IMPLIED, WITH RESPECT TO ANY EQUIPMENT, PARTS OR SERVICES PROVIDED PURSUANT TO THIS AGREEMENT, INCLUDING BUT NOT LIMITED TO THE IMPLIED WARRANTIES OF MERCHANTABILITY AND FITNESS FOR A PARTICULAR PURPOSE. NEITHER SENA NOR ITS DEALER SHALL BE LIABLE FOR ANY OTHER DAMAGES, INCLUDING BUT NOT LIMITED TO DIRECT, INDIRECT, INCIDENTAL, SPECIAL OR CONSEQUENTIAL DAMAGES, WHETHER IN AN ACTION IN CONTRACT OR TORT (INCLUDING NEGLIGENCE AND STRICT LIABILITY), SUCH AS, BUT NOT LIMITED TO, LOSS OF ANTICIPATED PROFITS OR BENEFITS RESULTING FROM, OR ARISING OUT OF, OR IN CONNECTION WITH THE USE OF FURNISHING OF EQUIPMENT, PARTS OR SERVICES HEREUNDER OR THE PERFORMANCE, USE OR INABILITY TO USE THE SAME, EVEN IF SENA OR ITS DEALER HAS BEEN ADVISED OF THE POSSIBILITY OF SUCH DAMAGES. IN NO EVENT WILL SENA OR ITS DEALERS TOTAL LIABILITY EXCEED THE PRICE PAID FOR THE PRODUCT.

13.3 HARDWARE PRODUCT WARRANTY DETAILS

WARRANTY PERIOD: SENA warranties embedded hardware Product for a period of one (1) year, and external hardware Product for a period of three (3) or five (5) years according to the Product type.

WARRANTY PROCEDURE: Upon return of the hardware Product SENA will, at its option, repair or replace Product at no additional charge, freight prepaid, except as set forth below. Repair parts and replacement Product will be furnished on an exchange basis and will be either reconditioned or new. All replaced Product and parts become the property of SENA. If SENA determines that the Product is not under warranty, it will, at the Customers option, repair the Product using current SENA standard rates for parts and labor, and return the Product at no charge in or out of warranty.

WARRANTY EXCLUSIONS: Damages caused by

- Accidents, falls, objects striking the SENA product,
- Operating the Product in environments that exceed SENA's temperature and humidity specifications,
- Power fluctuations, high voltage discharges,
- Improper grounding, incorrect cabling,
- Misuse, negligence by the customer or any other third party,
- Failure to install or operate the product (s) in accordance to their SENA User Manual,
- Failure caused by improper or inadequate maintenance by the customer or any other third party,
- Floods, lightning, earthquakes,
- Water spills,
- Replacement of parts due to normal wear and tear,
- Hardware has been altered in any way,
- Product that has been exposed to repair attempts by a third party without SENA's written consent,
- Hardware hosting modified SENA Software, or non-SENA Software, unless modifications have been approved by Sena.
- Battery component capacity degradation due to usage, aging, and with some chemistry, lack of maintenance.

13.4 SOFTWARE PRODUCT WARRANTY DETAILS

WARRANTY PERIOD: SENA warranties software Product for a period of one (1) year.

WARRANTY COVERAGE: SENA warranty will be limited to providing a software bug fix or a software patch, at a reasonable time after the user notifies SENA of software non-conformance.

13.5 THIRD-PARTY SOFTWARE PRODUCT WARRANTY DETAILS

The warranty policy of the third-party software is conformed to the policy of the corresponding vendor.

14 Regulatory Information

14.1 FCC

FCC Rule: Part 15 Subpart C Section 15.247

FCCID: S7AIW01

FCC Compliance Statement

This device complies with part 15 of the FCC Rules. Operation is subject to the following two conditions:

- (1) This device may not cause harmful interference, and
- (2) This device must accept any interference received,
Including interference that may cause undesired operation

Information to User

This equipment has been tested and found to comply with limits for a Class B digital device, Pursuant to Part 15 of the FCC Rules. These limits are designed to provide reasonable protection against harmful interference in a residential installation.

This equipment generate, uses and can radiate radio frequency energy and, if not installed and used in accordance with the instructions, may cause harmful interference to radio communications.

However, there is no guarantee that interference will not occur in a particular installation. If this equipment does cause harmful interference to radio or television reception, which can be determined by turning the equipment off and on, the user is encouraged to try to correct the interference by on or more of the following measures:

- ↘ Reorient or relocate the receiving antenna.
- ↘ Increase the separation between the equipment and receiver-Connect the equipment into an outlet a circuit different form that to which the receiver is connected.
- ↘ Consult the dealer or an experienced radio/TV technician for help.

RF Exposure Statement

The equipment complies with FCC RF radiation exposure limits set forth for an uncontrolled environment. This device and its antenna must not be co-located or operation in conjunction with any other antenna or transmitter.

Do not

Any changes or modifications to the equipment not expressly approved by the party responsible for compliance could void user's authority to operate the equipment.

14.2 CE

CE1177(!)

We, Sena Technologies, Inc., declare that the product(s):

- ProBee-ZE20S ZigBee OEM Module

to which this declaration relates is in conformity with the following standard(s) or other normative document(s)

- EN 60950-1
- ETSI EN 301 489-1
- ETSI EN 301 489-17
- ETSI EN 300 328

Following the provisions of

- EMC DIRECTIVE 1999/5/EC

14.3 TELEC

Technical Regulations for Specified Radio Equipment Article 2, Section 1 (19)

Certification No:

- ProBee-ZE20SDU : 010WWBT0090
- ProBee-ZE20SDS : 010WWBT0091
- ProBee-ZE20SDC : 010WWBT0092

14.4 KCC

Type Registration

Certification No: KCC-CRM-SNA-IW01

Basic Model Number: ProBee-ZE20SDU

Series Model Number: ProBee-ZE20SDS, ProBee-ZE20SDC, ProBee-ZE20SSU, ProBee-ZE20SSC

15 RF Information

Radio Frequency Range

2.405~2.480GHz

Number of Frequency Channel

16 channels

Transmission Method

DSSS (Direct Sequence Spread Spectrum)

Modulation Method

O-QPSK (Offset Quadrature Phase Shift Keying)

Radio Output Power

+8dBm

Receiving Sensitivity

-102dBm

Power Supply

DC3.3V