

**Universal Device Servers**

# **HelloDevice Super 시리즈**

**사용자 설명서**

**Version 1.3.3**

**2005-11-08**

## 저작권

Copyright 1998-2005, 세나테크놀로. All rights reserved.

세나테크놀로지는 자사 제품을 사전 통보 없이 변경 및 개선할 수 있는 권리를 가지고 있습니다.

## 등록 상표

HelloDevice™은 세나테크놀로지의 상표입니다.

Windows®는 Microsoft 사의 등록 상표입니다.

Ethernet®은 XEROX 사의 등록 상표입니다.

## 사용자 공지

시스템 결함으로 인한 손상, 사망 또는 재산상의 손해를 보호하기 위해, 적절한 백업 시스템과 필수 안전 장치는 필수적입니다. 시스템 고장으로 인한 결과에 대한 보호는 사용자 책임입니다. 본 장치는 생명 유지 또는 의료 시스템으로서는 사용 승인을 받지 않은 제품입니다.

본 기기에 대하여 세나테크놀로지의 서면 허가 없이 이루어진 변경 또는 개조에 대해 세나테크놀로지는 책임을 지지 않습니다.

## 기술 지원

세나테크놀로지

서울시 서초구 양재동 210번지

137-130, 대한민국

전화: (02) 573-5422

팩스: (02) 573-7710

email: support@sena.com

웹 사이트: <http://www.sena.com>

## Revision history

Revision	Date	Name	Description
V1.0.0	2003-09-19	I.S. Um	Initial Release
V1.0.1	2003-10-08	O.J. Jung	그림 5-6, 표 A.2 수정
V1.1.0	2004-01-09	I.S. Um	펌웨어 v1.1.0 에 따른 수정
V1.1.1	2004-01-30	O.J. Jung	오자 수정
V1.2.0	2004-06-11	O.J. Jung	펌웨어 v1.2.0 에 따른 수정 (SS100 모델 추가)
V1.2.1	2004-08-16	O.J. Jung	SS110 사양 수정
V1.2.2	2004-08-24	O.J. Jung	오자 수정 (SS 시리즈)
V1.3.0	2004-10-1	O.J. Jung	펌웨어 v1.2.0 에 따른 수정
V1.3.1	2004-10-15	O.J. Jung	부록 6 추가
V1.3.2	2005-05-18	O.J. Jung	부록 7 추가 , PC 카드 리스트 수정, DTR/DSR 동작에 관한 설명 수정
V1.3.3	2005-11-08	Hunn Lee	온도 및 습도 관련 변경

# 목차

1. 서론	8
1.1. 개요 .....	8
1.2. 패키지 체크 리스트 .....	9
1.3. 제품 사양 .....	10
1.4. 용어 및 약어 .....	12
2. 시작하기	14
2.1. 패널 레이아웃 .....	14
2.1.1. SS100 패널 레이아웃 .....	14
2.1.2. SS110 패널 레이아웃 .....	15
2.1.3. SS400 패널 레이아웃 .....	16
2.1.4. SS800 패널 레이아웃 .....	17
2.2. 하드웨어 연결하기 .....	18
2.2.1. 전원에 연결하기 .....	18
2.2.2. 네트워크에 연결하기 .....	18
2.2.3. 해당 장치에 연결하기 .....	20
2.2.4. 시스템 콘솔에 접속하기 .....	21
2.2.5. 시스템 콘솔 사용하기 .....	22
2.2.6. 원격 콘솔 사용하기 .....	24
2.3. 웹 브라우저 관리 인터페이스에 접속하기 .....	26
3. 네트워크 설정	28
3.1. IP 설정 .....	28
3.1.1. Static IP 주소 사용하기 .....	29
3.1.2. DHCP 사용하기 .....	30
3.1.3. PPPoE 사용하기 .....	31
3.2. SNMP 설정 .....	32
3.2.1. MIB-II 시스템 객체(MIB-II system objects) 설정 .....	33
3.2.2. 액세스 제어 설정(Access control settings) .....	33
3.2.3. 트랩 수신기 설정(Trap receiver settings) .....	34
3.2.4. SNMP를 이용한 관리 .....	34
3.3. 동적 DNS(Dynamic DNS) 설정 .....	35
3.4. SMTP 설정 .....	36
3.5. IP 필터링 .....	37
3.6. SYSLOG 서버 설정 .....	39
3.7. NFS 서버 설정 .....	39
3.8. Ethernet 설정 .....	40
3.9. 웹 서버 설정 .....	41

3.10. TCP	42
4.	43
4.1.	43
4.2.	46
4.2.1. Port Enable/Disable	47
4.2.2. Port Title	47
4.2.3. Apply All Port Settings	48
4.2.4.	49
4.2.5.	59
4.2.6. Port IP filtering	60
4.2.7.	61
4.2.8.	67
4.2.9.	67
4.2.10.	71
4.2.11. (Port Logging)	72
4.2.12.	74
4.3.	78
5. PC	80
5.1.	81
5.2. LAN	82
5.3. Serial Modem	83
5.4. ATA/IDE Fixed Disk Card Configuration	84
6.	85
6.1.	85
6.2.	86
6.3.	87
6.4.	88
6.5. (Device name)	88
6.6.	89
6.7.	90
6.8.	92
6.9.	94
7.	97
7.1. (Network Interfaces)	97
7.2.	97
7.3. IP	98
7.4. ICMP	100
7.5. TCP	102

7.6. UDP	103
8. CLI	104
8.1.	104
8.2.	104
8.3. Linux	105
8.3.1. Shell shell utilities:	105
8.3.2. File disk utils:	105
8.3.3.	105
8.3.4.	105
8.4. root system admin CLI	105
8.5. CLI Super	106
8.5.1. / :	106
8.5.2. CLI :	106
8.6. script	106
8.7. File	107
8.8.	108
8.8.1. telnet disable	108
9. 가	110
9.1.	110
9.2.	110
9.3.	111
9.4.	111
1.	113
A 1.1 Ethernet Pin outs.....	113
A 1.2 SS100 Pin out .....	113
A 1.3 SS110/400/800 Pin out.....	114
A 1.4 Ethernet .....	114
A 1.5 .....	115
A 1.5.1 RS232 (SS100 ).....	115
A 1.5.2 SS110/400/800 RS232 .....	115
A 1.5.3 RS422/485 (SS100 ).....	116
A 1.5.4 SS110/400/800 RS422/485 .....	117
2. Super 가 PC	119
3. Super	121
A 3.1 System.cnf .....	121
A 3.2 Redirect.cnf .....	123
4.	127
5. Guide to the Bootloader	128

A 5.1	.....	128
A 5.2	.....	128
A 5.3 RTC	.....	129
A 5.4	.....	129
A 5.5 Firmware upgrade	.....	133
6. Serial/IP Super		136
A 6.1 Super Serial/IP	.....	136
A 6.2 - Telnet SSLv3 encryption	.....	137
7. SSL		142
A 7.1. OpenSSL	.....	142
A 7.2. root CA (for Self-signed)	.....	142
A 7.3. (certificate request)	.....	144
A 7.4. (certificate request)	.....	145
A 7.5. SS	.....	146

# 1.

## 1.1.

HelloDevice Super Ethernet  
( ) . HelloDevice Super TCP/IP  
UDP  
. HelloDevice Super PPPoE(PPP-over-Ethernet)  
DSL  
DHCP, PPPoE, DNS(DDNS: Dynamic DNS)  
DSL  
. HelloDevice Super DNS  
HelloDevice Super Telnet,  
,  
,  
,  
Telnet  
HelloDevice Super  
, HelloDevice Super  
SSLv2, SSLv3, TLSv1 . 가 , HelloDevice  
Super 가 IP  
HelloDevice Super 가  
-  
- / (POS)  
-  
-  
-  
HelloDevice Super RS232/422/485  
, , ,



## 1.2.

- SS100/110/400/800
- 110V      230V
- (SS100 )
- CAT5      (SS100 )
- (SS100 )
- Quick Start Guide
- Serial/IP Com Port Redirector, HelloDevice Manager  
CD-ROM

### 1.3. 제품 사양

	SS100	SS110	SS400	SS800
시리얼 인터페이스	1 포트		4 포트	8 포트
	시리얼 속도 75bps ~ 230Kbps			
	흐름 제어: 하드웨어 RTS/CTS, 소프트웨어 Xon/Xoff			
	RJ45 커넥터			
	신호: RS232 Rx, Tx, RTS, CTS, DTR, DSR, DCD, GND RS422 Rx+, Rx-, Tx+, Tx- RS485 Data+, Data-			
	모뎀 제어: DTR/DSR and RTS/CTS			
네트워크 인터페이스	RJ45 Ethernet 커넥터를 장착한 10/100 Base Ethernet			
	고정 및 유동 IP 주소 지원			
프로토콜	<ul style="list-style-type: none"> <li>- ARP, IP/ICMP, TCP, UDP, Telnet, SSH v1 &amp; v2,</li> <li>- SSL v2 &amp; v3, TLS v1</li> <li>- DNS, Dynamic DNS, HTTP, HTTPS,</li> <li>- SMTP with/without Authentication, pop-before SMTP,</li> <li>- DHCP client, NTP, PPPoE, SNMP v1 &amp; v2</li> </ul>			
PCMCIA	없음	다음 PC 카드 지원: ATA 플래쉬 메모리 카드 802.11b 무선 랜 카드 10/100 Base-TX 랜 카드 모뎀 카드		
보안	사용자 ID 및 암호			
	HTTPS			
	보안 터미널 인터페이스: SSH			
	데이터 암호화: SSLv2/v3, TLS v1, 3DES 및 RC4			
	IP 주소 필터링			
	SCP			
Modem emulation	AT 명령어 지원			
관리	시리얼 콘솔 포트, telnet, 웹, HelloDevice Manager			
	운영체제 지원: Windows 98/ME/NT/2000/XP			
	시스템 로깅 오류 로그를 자동으로 email 전달			
	시스템 상태 다양한 시스템 상태 표시 기능			
	펌웨어 telnet, 콘솔 또는 웹 인터페이스를 통한 다운로드 가능 기능			
진단 LED	Power Ready 10/100 Base Link, Act 각 포트 : Serial InUse(SS400/800만 해당)/Rx/ Tx PC 카드(SS110/400/800만 해당)			
환경	작동 온도: 0°C ~ 50°C 보관 온도: -20°C ~ 66°C 습도: 90% Non-condensing			

전원	5VDC 0.5A @ 5VDC	7.5VDC 1A @ 7.5VDC	5VDC 1.5A @ 5VDC
크기 L x W x H (mm)	100 x 72 x 25 (mm) 3.94 x 2.83 x 0.98 (in.)	150 x 103 x 26 (mm) 5.9 x 4.0 x 1.0 (in.)	245 x 153 x 30 (mm) 9.6 x 6 x 1.2 (in.)
	DIN-rail mount option		-
무게 (kg)	0.240	0.455	1.5
인증	FCC(A), CE(A), MIC		
품질 보증 기간	5년		

# 1.4

Super

## MAC

LAN

MAC(Media Access Control)

(Ethernet LAN Ethernet .)

MAC

6  
12

OUI(Organization Unique Identifier)

6

. Super MAC 00-01-95-xx-xx-xx ,

“ ”

가

IP

“ ” “ ”가

(“ ”).

/

/

/

HTML

HTML

<b>ISP</b>	Internet Service Provider
<b>PC</b>	Personal Computer
<b>NIC</b>	Network Interface Card
<b>MAC</b>	Media Access Control
<b>LAN</b>	Local Area Network
<b>UTP</b>	Unshielded Twisted Pair
<b>ADSL</b>	Asymmetric Digital Subscriber Line
<b>ARP</b>	Address Resolution Protocol
<b>IP</b>	Internet Protocol
<b>ICMP</b>	Internet Control Message Protocol
<b>UDP</b>	User Datagram Protocol
<b>TCP</b>	Transmission Control Protocol
<b>DHCP</b>	Dynamic Host Configuration Protocol
<b>SMTP</b>	Simple Mail Transfer Protocol
<b>FTP</b>	File Transfer Protocol
<b>PPP</b>	Point-To-Point Protocol
<b>PPPoE</b>	Point-To-Point Protocol over Ethernet
<b>HTTP</b>	HyperText Transfer Protocol
<b>DNS</b>	Domain Name Service
<b>DDNS</b>	Dynamic Domain Name Service
<b>SNMP</b>	Simple Network Management Protocol
<b>RADIUS</b>	Remote Access for Dial-In User Service
<b>SSH</b>	Secure Shell
<b>NTP</b>	Network Time Protocol
<b>UART</b>	Universal Asynchronous Receiver/Transmitter
<b>Bps</b>	Bits per second (baud rate)
<b>DCE</b>	Data Communications Equipment
<b>DTE</b>	Data Terminal Equipment
<b>CTS</b>	Clear to Send
<b>DSR</b>	Data Set Ready
<b>DTR</b>	Data Terminal Ready
<b>RTS</b>	Request To Send
<b>DCD</b>	Data Carrier Detect

## 2.

- 2.1 Super LED
- 2.2 Super
- 2.3 telnet Super
- ( )
- /Ethernet ( )
- ( )
- ( NIC)가 PC RS232

### 2.1.

#### 2.1.1. SS100

SS100 6 LED 가  
 Ethernet , 10/100 Base Ethernet , Ethernet 100 Base-T

2-1 SS 100 LED

(Status)	Power	
	Ready	가 가 ( 6.2 )
(Serial Port)	Rx/Tx	SS100 가
Ethernet(Ethernet)	100Base	100 Base Ethernet
	Link	10 100 Base Ethernet
	Act	SS 100 Ethernet 가

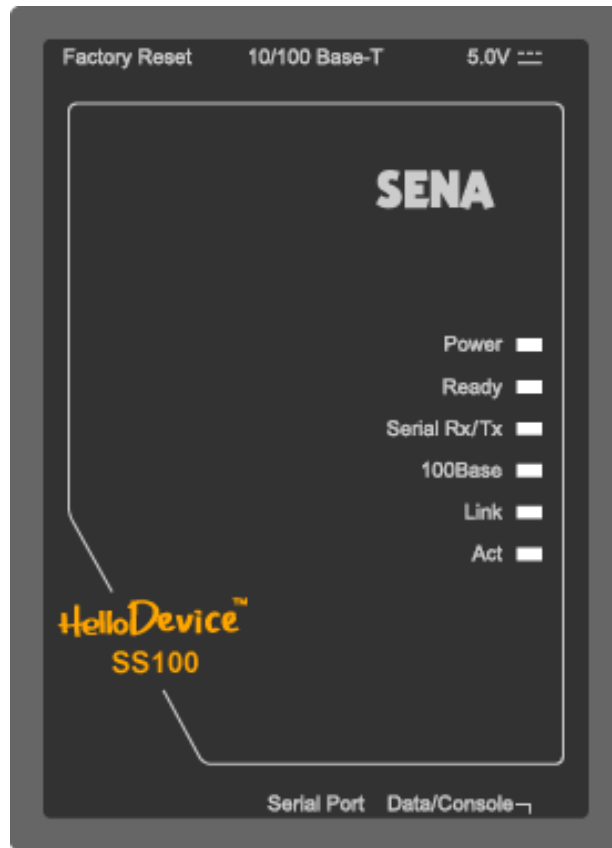

2-1 SS100

### 2.1.2. SS110

2-2 가 (Power), (Act) LED

2-3 ( : System, Ethernet (Ready) PC Ethernet 100Mbps(Ethernet 100Mbps), (Receive) Serial Ports). (PC Card Interface) (Link), (Transmit)

SS 110/400/800

2-2 LED



2-2 SS110

2-1 SS 110/400/800 LED

System	Power	
	Ready	가
	PC card	PCMCIA 가
Ethernet	100Mbps	100Base-TX
	LINK	Ethernet
	Act	Super Ethernet 가
Serial port	InUse	가 (SS400/800 가 )
	Rx/Tx	Super 가

### 2.1.3. SS400

2-3 SS400 LED 가 .  
 ( : System, Ethernet Serial Ports). (Power),  
 (Ready), PCMCIA (PCMCIA Interface)



Ethernet 100Mbps(Ethernet 100Mbps), (Link) (Act)  
(InUse), (Receive) (Transmit)  
2-1 LED RJ45  
Ethernet , SS400 ,



2-3 SS400

#### 2.1.4. SS800

SS800 SS400 . SS800 8 가  
, SS400 4 가 , 2 2.1.3 SS400

## 2.2.

- Super
- Super Ethernet
- 

### 2.2.1.

Super

(SS400/800)

(SS100/110)

[Power]

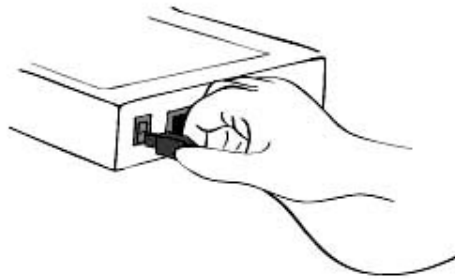

2-1 SS100/110

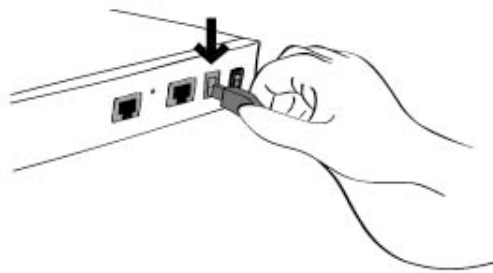

2-2 SS400/800

### 2.2.2.

Ethernet

Super

Ethernet

Ethernet

Ethernet

- [Link]

- [Act]

Ethernet

, Super

- Super 가 100Base-TX [100Mbps]

- 10Base-T [10Mbps]

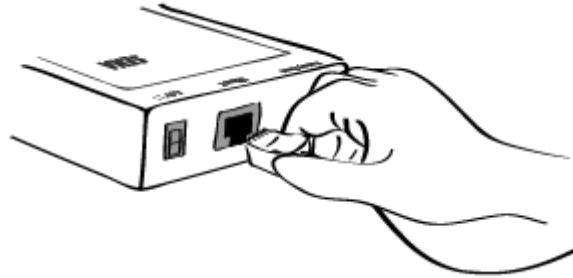

2-3 SS100

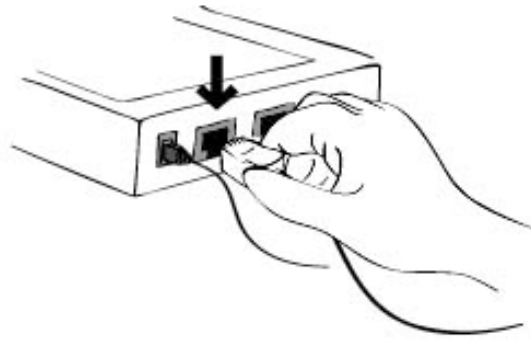

2-4 SS110

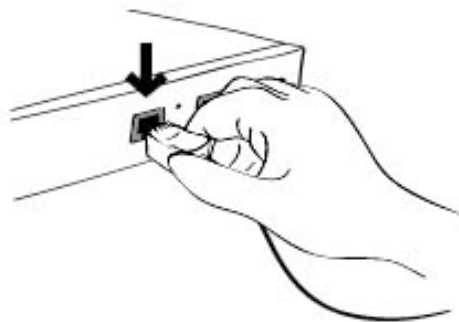

2-5 SS400/800

### 2.2.3.

Super

가

가

Super

1.

:  
SS100

Data/Console

Console

SS100

2.2.5

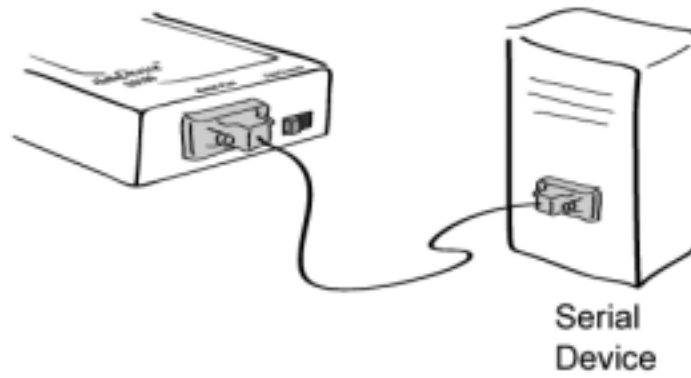

2-6

SS100

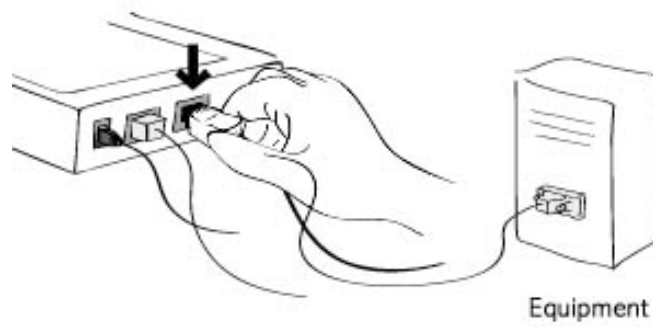

2-7

SS110

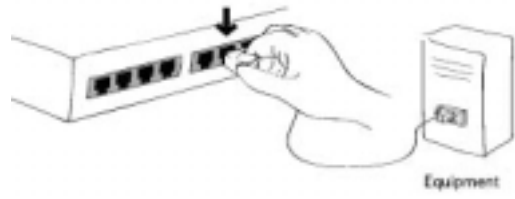
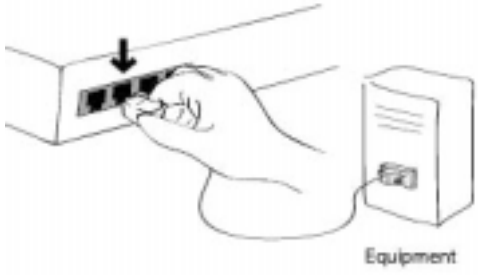

2-8 SS400( ) / SS800( )

**2.2.4.**

Super 가 가 . , 가  
 , Super , GUI(Graphic User Interface)  
 CLI(Command Line Interface) ..

- :  
 /Ethernet Super

- :  
 Super

telnet(TCP 23) SSH(TCP 22)

- :  
 Super Internet Explorer  
 Netscape Navigator Super

SUPER

## 2.2.5.

- 1) /Ethernet Super

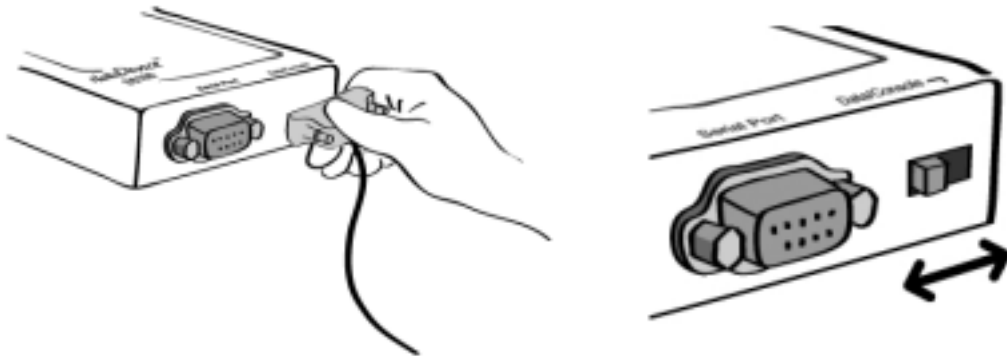

2-9 SS100

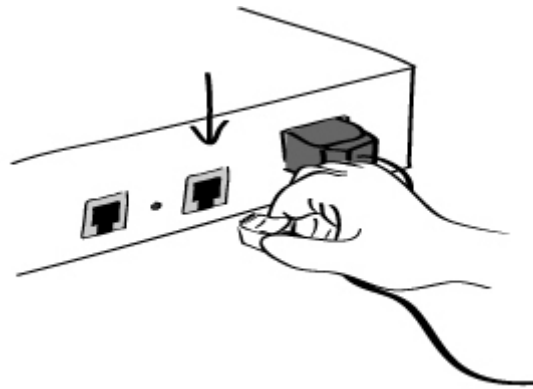

2-10 SS110

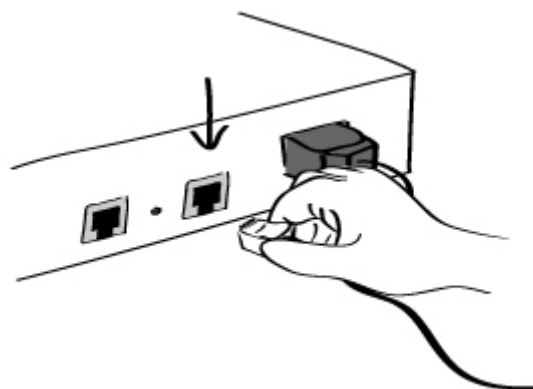

2-11 SS400/800

- 2) RJ45-DB9 (female adapter)  
3)  
4) (HyperTerminal)

- 9600 Baud rate
- Data bits 8
- Parity None
- Stop bits 1
- No flow control

5) [ENTER]

6) Super

Login: root Password: root

Login: admin Password: admin

```
192.168.161.5 login: root
Password:****
root@192.168.161.5:~#
```

7) CLI . CLI 8 CLI

8) 가 "ss.edit" , 2-12

```
root@192.168.161.5:~#ss.edit
```

```
-----
Welcome to SS-800 configuration page
Current time: 08/22/2003 21:52:36 F/W REV.: v0.4.0
Serial No.: SS800438349-42944 MAC address: 00-01-95-04-19-5a
IP mode: DHCP IP address: 192.168.14.7
-----
```

```
Select menu:
1. Network configuration
2. Serial port configuration
3. PC Card configuration
4. System administration
5. Save changes
6. Exit without saving
7. Exit and apply changes
8. Exit and reboot
<Enter> Refresh
----->
```

2-12

(SS800)

[ENTER]

Super

- 가 5. Save Changes
- 7. Exit and Apply Changes
- 8. Exit and Reboot

### 2.2.6.

- 3. Super IP
- 3.5 IP
- disable

- 1) Telnet (TeraTerm-Pro Hyper Terminal)
- IP port number Super
- port number 23

telnet 192.168.161.5

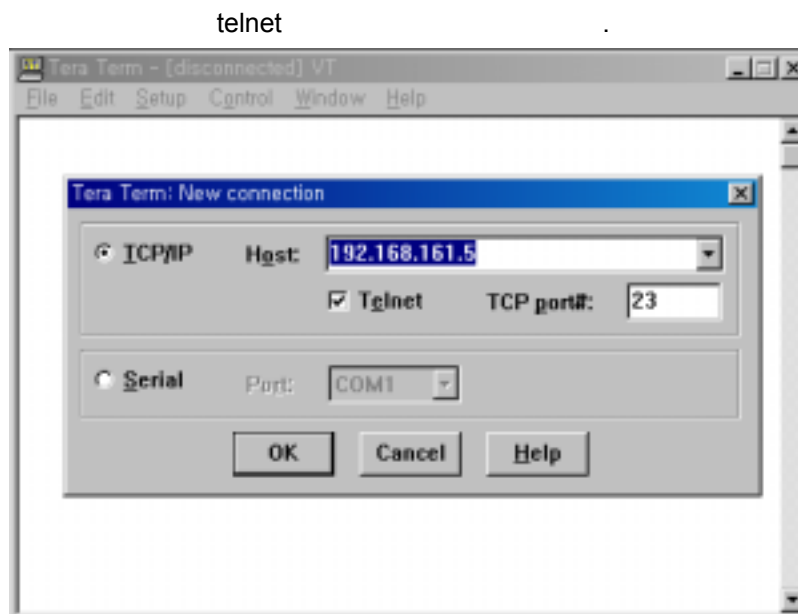

2-13 Telnet

(TeraTerm Pro)



- 2) Super , root root  
admin 가
- 3) Super 가 , CLI .

### 2.3.

Super HTTP HTTPS(HTTP over SSL) Super  
 Super  
 IP 가 URL/Location  
 Super

**Login: root Password: root**  
**Login: admin Password: admin**

: Super Super  
 IP ( 가 )

**User authentication required. Login please.**

User ID :

Password :

Move to :  Configuration page  Customer page

2-14 Super

2-14 Super  
 가 (Configuration page)

, 2-18 Super  
 가 (Customer page) Super

9. 가

2-15 Super  
 가

가 가

[ (Cancel)] [ (Save to flash)], [ (Save & apply)] [ (Save)]

to Flash])

[ (Apply Changes)]

가 [ (Apply Changes)]

Super

[ (Save & Apply)]

가

[ (Cancel)]

**SENA TECHNOLOGIES** Device Server, Super Series Management

**Network**

- IP configuration
- SNMP configuration
- Dynamic DNS configuration
- SMTP configuration
- IP filtering
- SYSLOG server configuration
- NFS server configuration
- Web server configuration
- Ethernet configuration
- TCP service configuration

**Serial port**

**PC card**

**System administration**

**System statistics**

Apply changes

Login as a different user

Logout

Reboot

Customer page

**IP configuration**

IP mode :	Static
IP address :	192.168.161.5
Subnet mask :	255.255.0.0
Default gateway :	192.168.1.1
Primary DNS (0.0.0.0 for auto) :	168.126.63.1
Secondary DNS (optional) :	168.126.63.2
PPPoE user name :	whoever
PPPoE password :	*****
Confirm PPPoE password :	*****

Save to flash Save & apply Cancel

Copyright © 2003 Sena Technologies, Inc. All rights reserved

2-15 Super

### 3.

#### 3.1. IP

Super , IP 가 . IP 가  
Super IP  
Super , IP 가  
Super IP 3

- **Static IP**
- **DHCP** (Dynamic Host Configuration Protocol)
- **PPPoE** (Point-to-Point Protocol over Ethernet)

Super **192.168.161.5** IP **Static IP**  
3-1 3 IP 3-1 IP  
GUI

3-1 IP

<b>Static IP</b>	IP address
	Subnet mask
	Default gateway
	Primary DNS/ Secondary DNS
<b>DHCP</b>	Primary DNS/ Secondary DNS (Optional)
<b>PPPoE</b>	PPPoE Username
	PPPoE Password
	Primary DNS/ Secondary DNS (Optional)

IP configuration	
IP mode :	Static
IP address :	192.168.16.1
Subnet mask :	255.255.0.0
Default gateway :	192.168.1.1
Primary DNS (0.0.0.0 for auto) :	168.126.63.1
Secondary DNS (optional) :	168.126.63.2
PPPoE user name :	whoever
PPPoE password :	*****
Confirm PPPoE password :	*****

### 3-1 IP

#### 3.1.1. Static IP

가 static IP , Super IP  
 IP , Subnet mask, gateway  
 DNS server가

: Super

- IP address  
 Static IP

IP  
 IP  
 : 192.168.1.x IP ISP (Internet Service Provider)가  
 (private) Super

- Subnet mask

LAN  
 Super  
 TCP/IP 가 Super

(Physical address)

• **Default gateway**

가

ISP

Super

가

IP

IP

• **Primary and Secondary DNS**

가

IP

DNS(Domain Name System)

. DNS

IP

. **sena.com**

가

. DNS

TCP/IP

IP

Super

DNS

DNS

IP

. Super

**Primary DNS server**

**Secondary DNS server**

DNS

IP

. Secondary

DNS

Primary DNS

**3.1.2. DHCP**

(DHCP)

가 IP

. DHCP

가 IP

가

IP

Static IP

, IP

가

,

IP

가

. IP

가 DHCP

IP

,

,

, DNS

가

. DHCP

IP

가

“ (lease)”

. IP

DHCP

IP 가

DHCP

DHCP

, Super

DHCP

. DHCP

IP

, DNS “ ” . Super  
 . “ ”가 , Super DHCP  
 ” ” . DHCP 가 , Super  
 IP . DHCP 가  
 , Super DHCP IP .  
 : DHCP DNS Super  
 .. DNS 가 , primary secondary  
 DNS IP . DNS ,  
 primary secondary DNS IP 0.0.0.0 ( ) .  
 DHCP 가 IP IP .  
 DHCP , Super 가 IP .  
 DHCP IP 가 Super Super  
 . DHCP IP Super  
 Super MAC .

### 3.1.3. PPPoE

PPPoE Ethernet LAN( )  
 PPPoE  
 ADSL,  
 PPPoE Super PPPoE ADSL  
 PPPoE 가 . Super PPPoE ADSL  
 . Super  
 PPPoE Super PPPoE  
 Super IP , , DNS  
 Super Super 가 .  
 Super PPPoE .  
 : PPPoE DNS Super  
 . DNS 가 , primary secondary  
 DNS IP . DNS ,  
 primary secondary DNS IP 0.0.0.0 ( ) .

### 3.2. SNMP

Super SNMP v1 v2 SNMP(Simple Network Management Protocol)

NMS SNMP

Super GET, SET, GET-Next, TRAP (TRAPs), (GET), (SET). SNMP v2

GET-Bulk 가

SNMP MIB-II , TRAP

3-2 SNMP

**SNMP configuration**

MIB-II system objects

sysContact :	<input style="width: 90%;" type="text" value="administrator"/>
sysName :	<input style="width: 90%;" type="text" value="SS800"/>
sysLocation :	<input style="width: 90%;" type="text" value="my location"/>
sysService :	<input style="width: 90%;" type="text" value="7"/>
EnableAuthenTrap :	<input type="button" value="Yes"/> ▾
EnableLoginTrap :	<input type="button" value="No"/> ▾
EnableLinkUpTrap :	<input type="button" value="No"/> ▾

Access control settings (NMS)

IP Address	Community	Permission
<input style="width: 95%;" type="text" value="0.0.0.0"/>	<input style="width: 95%;" type="text" value="public"/>	<input type="button" value="Read only"/> ▾
<input style="width: 95%;" type="text" value="0.0.0.0"/>	<input style="width: 95%;" type="text" value="public"/>	<input type="button" value="Read only"/> ▾
<input style="width: 95%;" type="text" value="0.0.0.0"/>	<input style="width: 95%;" type="text" value="public"/>	<input type="button" value="Read only"/> ▾
<input style="width: 95%;" type="text" value="0.0.0.0"/>	<input style="width: 95%;" type="text" value="public"/>	<input type="button" value="Read only"/> ▾

Trap receiver settings

IP Address	Community	Version
<input style="width: 95%;" type="text" value="0.0.0.0"/>	<input style="width: 95%;" type="text" value="public"/>	<input type="button" value="v1"/> ▾
<input style="width: 95%;" type="text" value="0.0.0.0"/>	<input style="width: 95%;" type="text" value="public"/>	<input type="button" value="v1"/> ▾
<input style="width: 95%;" type="text" value="0.0.0.0"/>	<input style="width: 95%;" type="text" value="public"/>	<input type="button" value="v1"/> ▾
<input style="width: 95%;" type="text" value="0.0.0.0"/>	<input style="width: 95%;" type="text" value="public"/>	<input type="button" value="v1"/> ▾

3-2 SNMP Configuration



### 3.2.1. MIB-II (MIB-II system objects)

MIB-II (Authentication-failure traps) Super SNMP 가  
 sysName, sysContact, sysLocation, sysService enableAuthenTrap MIB-II (OID)가

OID

- sysContact: (Super )
- sysName: FQDN(Fully Qualified Domain Name)
- sysLocation: ( , 384 , , )
- sysService( ) : Super (7)
- EnableAuthenTrap: SNMP 가 ;
- EnableLinkUpTraps: SNMP 가 Ethernet
- EnableLoginTrap: SNMP 가

가 MIB 가 ,  
 MIB SNMP RFC 1066, 1067, 1098, 117, 1318 1213

### 3.2.2. (Access control settings)

Super SNMP  
 Super SNMP  
 IP 가 ( IP 0.0.0.0  
 ), 가 Super SNMP

### 3.2.3. (Trap receiver settings)

Super SNMP (TRAP)

### 3.2.4. SNMP

NMS( ) SNMP SNMP Super  
 Super 가 NMS SNMP 가  
 NMS SNMP  
 3-3 Super SNMP MIB-II OID  
 SNMP

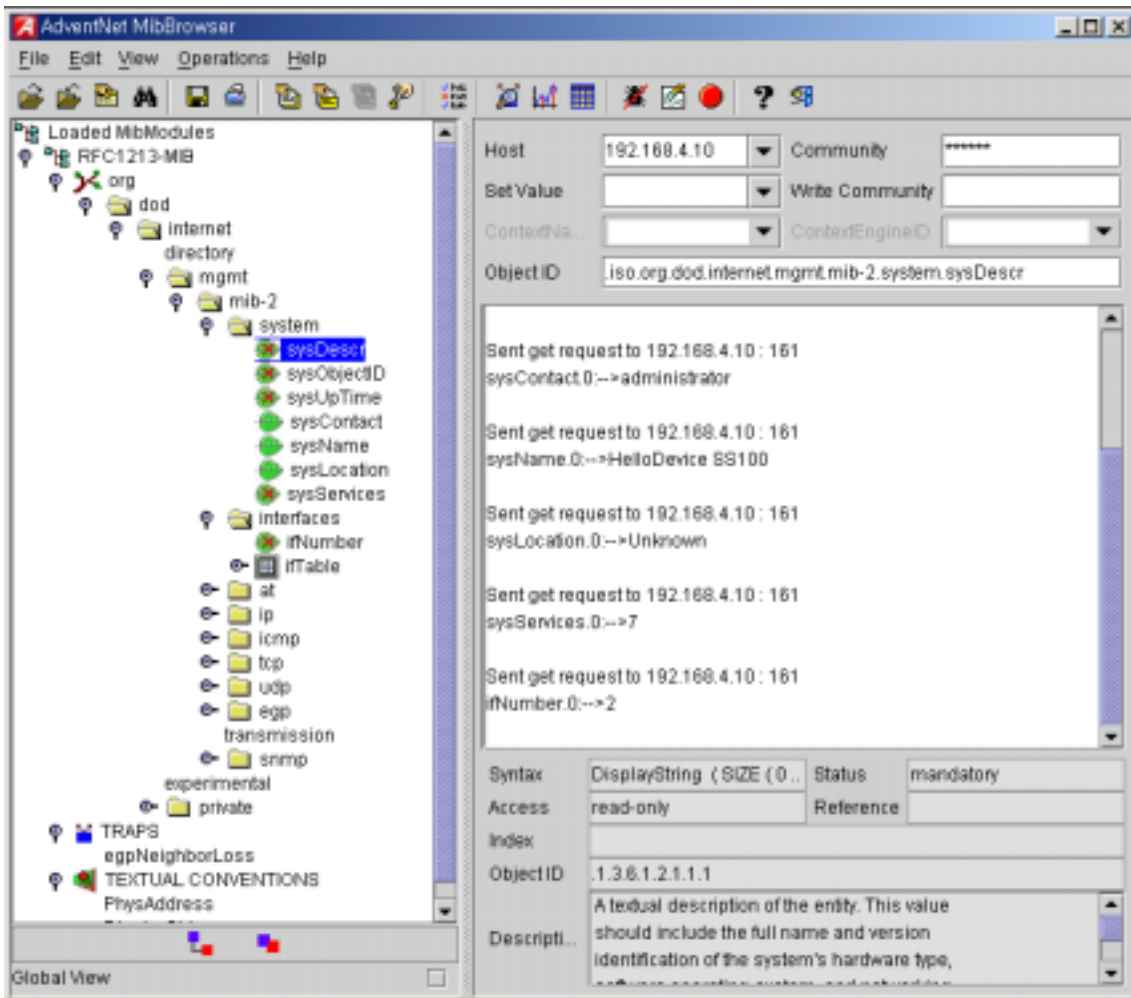

3-3 SNMP Super SNMP MIB-II OID  
 (AdventNet MIB )

### 3.3. DNS(Dynamic DNS)

가 Super DSL DHCP ,  
 , IP 가 . IP  
 , IP 가 . 가 telnet  
 DNS , ISP  
 . DNS , IP DNS  
 Super .  
 , Super Dynamic DNS Network Services (www.dyndns.org)  
 DNS DNS  
 Dynamic DNS Network Services가 DNS ,  
 NIC(Network Information Center-http://members.dyndns.org)  
 Dynamic DNS Network Services Members NIC DNS  
 가 .  
 DNS , DNS 가 가 , Domain name,  
 User name Password , Domain  
 name Super  
 3-4 DNS

Dynamic DNS configuration	
Dynamic DNS :	Enabled ▾
Domain Name :	ss800.dyndns.biz
User Name :	ss800-user
Password :	*****
Confirm password :	*****

Save to flash Save & apply Cancel

3-4 DNS

### 3.4. SMTP

가 Super SMTP  
 email Super SMTP  
 • SMTP  
 • SMTP  
 • POP-before-SMTP

#### 3-6. SMTP

SMTP

- SMTP server IP address
- SMTP user name
- SMTP user password
- Device mail address

Device mail address email, Super  
 SMTP Server email  
 email (i.e. arbitrary\_user@yahoo.com or anybody@sena.com) user name  
 SMTP POP-before-SMTP mode가, SMTP  
 SMTP password가

SMTP configuration	
SMTP enable/disable :	Enabled ▾
SMTP server name :	smtp.yourcompany.com
SMTP mode :	SMTP without authentication ▾
SMTP user name :	admin
SMTP password :	*****
Confirm SMTP password :	*****
Device mail address :	SS800@yourcompany.com

Save to flash   Save & apply   Cancel

3-5 SMTP

SMTP configuration	
SMTP enable/disable :	Enabled ▾
SMTP server name :	smtp.yourcompany.com
SMTP mode :	SMTP without authentication ▾
SMTP user name :	POP before SMTP
SMTP password :	SMTP without authentication
Confirm SMTP password :	SMTP authentication
Device mail address :	SS800@yourcompany.com

3-6 SMTP

SMTP

### 3.5. IP

Super IP 가

Super

- IP 가 Super
- Super
- 가 Super

Telnet , SSH IP

(enabled) (disabled) IP

“(Enabled)”

Super

IP

Super

Super IP

255.255.255.255

가 Super , IP

0.0.0.0 3-2

“Any( )”

**IP filtering**

**Telnet IP filtering**

Configuration via telnet :

Allowed base host IP :

Subnet mask to be applied :

**SSH IP filtering**

Configuration via ssh :

Allowed base host IP :

Subnet mask to be applied :

**Web IP filtering**

Configuration via web :

Allowed base host IP :

Subnet mask to be applied :

3-7 IP

3-2 Input examples of allowed remote hosts

가	Input format	
	Base Host IP address	Subnet mask
Any host	0.0.0.0	0.0.0.0
192.168.1.120	192.168.1.120	255.255.255.255
192.168.1.1 ~ 192.168.1.254	192.168.1.0	255.255.255.0
192.168.0.1 ~ 192.168.255.254	192.168.0.0	255.255.0.0
192.168.1.1 ~ 192.168.1.126	192.168.1.0	255.255.255.128
192.168.1.129 ~ 192.168.1.254	192.168.1.128	255.255.255.128

"Enabled"     "Disabled"    IP  
 "Enabled"     " (Enabled)"    Super  
 ( )

### 3.6. SYSLOG

Super , SYSLOG  
 service . SYSLOG service , SYSLOG IP  
 facility . 3-8 SYSLOG server  
 configuration .

**SYSLOG server configuration**

SYSLOG service :

SYSLOG server IP address :

SYSLOG facility :

3-8 SYSLOG

Super SYSLOG  
 "remote reception allowed" . Super SYSLOG  
 , 가 UDP  
 가  
 Super local0 local7 SYSLOG Facility  
 Facility , SYSLOG Super  
 SYSLOG service가 가 SYSLOG  
 Super  
 SYSLOG /  
**4.3.6** **8.2**

### 3.7. NFS

Super NFS(Network File System) NFS  
 . NFS IP  
 NFS 3-9 NFS

NFS server configuration	
NFS service :	Disabled ▾
NFS server IP address :	192.168.200.100
Mounting path on NFS server :	/

### 3-9 NFS

Super NFS , Super NFS  
 “read and write allowed” . Super NFS  
 , 가 UDP  
 가 .  
 NFS 가 가 NFS , Super  
 NFS /  
 4.2.11 6.2

## 3.8. Ethernet

Super Ethernet mode .  
 - Auto Negotiation  
 - 100 BaseT Half Duplex  
 - 100 BaseT Full Duplex  
 - 10 BaseT Half Duplex  
 - 10 BaseT Full Duplex  
 Ethernet mode , Ethernet mode  
 Auto Negotiation , Auto Negotiation  
 가 . Ethernet mode , Super  
 가 .

Ethernet configuration	
Ethernet mode :	Auto Negotiation ▾

### 3-10 Ethernet



### 3.9.

Super HTTP HTTPS(HTTP Over SSL)  
 Enabled Disabled 3-11

**Web server configuration**

HTTP service :

HTTPS service :

Web page refresh rate for statistics data display (0-1800, 0 for no refresh) :  seconds

Default web page :

Customer web start page :  HTML (index.html)  CGI (cgi-bin/default)

Customer page authentication :

3-11

(web page refresh rate)

, IP, ICMP, TCP

UDP

(Refresh)

7.

가

HTML

CGI

Super

(Configuration page)

“disabled”

9.3

### 3.10. TCP

TCP lock-up , TCP lock-up ,  
 lock-up , Super TCP keep-alive  
 Super 가 keep alive

Super TCP "keepalive" , 3

- TCP keepalive time (sec):

keepalive

15

- TCP keepalive probes (times):

keepalive

가

3

- TCP keepalive intervals (sec):

Keepalive

5

, Super

가

15 가

5

3 keepalive

TCP service configuration	
TCP keepalive time(sec) :	<input type="text" value="15"/>
TCP keepalive probes(times) :	<input type="text" value="3"/>
TCP keepalive intervals(sec) :	<input type="text" value="5"/>

3-12 TCP keep-alive

## 4.

### 4.1.

host mode,

host mode

- **TCP :**

TCP

TCP

. TCP

, TCP

, TCP

가

- **UDP :**

UDP

UDP

TCP

- **Modem emulation :**

AT

가

AT

port logging

server PC

ATA/IDE fixed disk card

MEMORY, SYSLOG server, NFS

. port event

Super

email

SNMP trap

MEMORY

Super

SYSLOG server, NFS server

PC

ATA/IDE fixed disk card

4-1

<b>All serial ports setting</b>  <b>Or</b>  <b>Individual serial port setting #1~#8(1/4)</b>	Port Enable/Disable		
	Port title		
	Apply all port settings (Individual serial port setting only)		
	<b>Host mode</b>	<b>TCP</b>	TCP listening port
			Telnet protocol
			Max allowed connection
			Cyclic connection
			Inactivity timeout (0 for unlimited)
		<b>UDP</b>	UDP listening port
			Max allowed connection
			Accept UDP datagram from unlisted remote host or not
			Send to recent unlisted remote host or not
			Inactivity timeout (0 for unlimited)
	<b>Modem emulation</b>		
	<b>Remote host<sup>1</sup></b>	Add or Edit a remote host <sup>2</sup> Primary host address Primary host port Secondary host address Secondary host port	
		Remove a remote host	
	<b>Port IP filtering<sup>3</sup></b>	Allowed host IP	
		Subnet mask to be applied	
	<b>Cryptography<sup>4</sup></b>	Encryption method None/SSLv2/SSLv3/SSLv3 rollback to v2/ TLSv1/3DES/RC4	
		Cipher suite selection	
		Verify client (server mode only)	
		Verify certificate chain depth	
		Check the certificate CN	
	<b>Filter application</b>	Filter application path	
		Filter application arguments	
	<b>Serial Port Parameters</b>	Type	
		Baud rate	
		Data bits	
		Parity	
		Stop bits	
		Flow control	
		DTR behavior	
		DSR behavior	
Inter-character timeout (ms)			
<b>Modem</b>	Enable/Disable modem		
	Modem init-string		
	DCD behavior		
<b>Port logging</b>	Enable/Disable Port logging		
	Port log storage location		
	Port log buffer size		
	Display port log		
<b>Port event handling</b>	Enable/Disable port event handling		
	Notification interval		
<b>Email</b>			
Enable/Disable Email notification			

<sup>1</sup> TCP/UDP

<sup>2</sup> TCP secondary remote host

<sup>3</sup> TCP/UDP

<sup>4</sup> TCP 該當.

		<b>notification</b>	Title of Email
			Recipient's Email address
		<b>SNMP notification</b>	Enable/Disable SNMP notification
			Title of SNMP trap
			SNMP trap receiver's IP address
			SNMP trap community
		Add/Edit a keyword Keyword string Email notification SNMP trap notification Port command	SNMP trap version
			Remove a keyword

4-1 -

가

Host mode	Description		
	Mode <sup>5</sup>	Encryption <sup>6</sup>	Telnet <sup>7</sup>
<b>TCP</b>	TCP	Disabled	Disabled
<b>TCPs</b>	TCP	Enabled	Disabled
<b>TEL</b>	TCP	Disabled	Enabled
<b>TELS</b>	TCP	Enabled	Enabled
<b>UDP</b>	UDP	* <sup>8</sup>	*
<b>Modem Emulation</b>	Modem Emulation	*	*

, [All port configuration]

[All]

[Port

Title]

<sup>5</sup> 4.2.4  
<sup>6</sup> 4.2.7  
<sup>7</sup> 4.2.4.1 TCP  
<sup>8</sup>

Serial port configuration				
All port configuration				
Port#	Title	Host mode	Local port	Serial-settings
All	Port #	TCP	7001	RS232-9600-N-8-1-No
Individual port configuration				
Port#	Title	Host mode	Local port	Serial-settings
1	Port #1	TCP	7001	RS232-9600-N-8-1-No
2	Port #2	TCPs	7002	RS232-9600-N-8-1-No
3	Port #3	TEL	7003	RS232-9600-N-8-1-No
4	Port #4	UDP	7004	RS232-9600-N-8-1-No
5	Port #5	Modem emulation	7005	RS232-9600-N-8-1-No
6	Port #6	TCP	7006	RS232-9600-N-8-1-No
7	Port #7	TCP	7007	RS232-9600-N-8-1-No
8	Port #8	TELS	7008	RS232-9600-N-8-1-No

4-1

## 4.2.

Super

12

1. Port enable/disable
2. Port title
3. Apply all port settings
4. Host mode
5. Remote host: *Available only when the host mode is set to TCP or UDP mode*
6. Port IP filtering: *Available only when the host mode is set to TCP or UDP mode*
7. Cryptography: *Available only when the host mode is set to TCP mode and Modem Emulation mode*
8. Filter application
9. Serial port parameters
10. Modem configuration
11. Port logging
12. Port event handling: *Available only when the port-logging feature of the port is enabled*

[--- Move to ---]

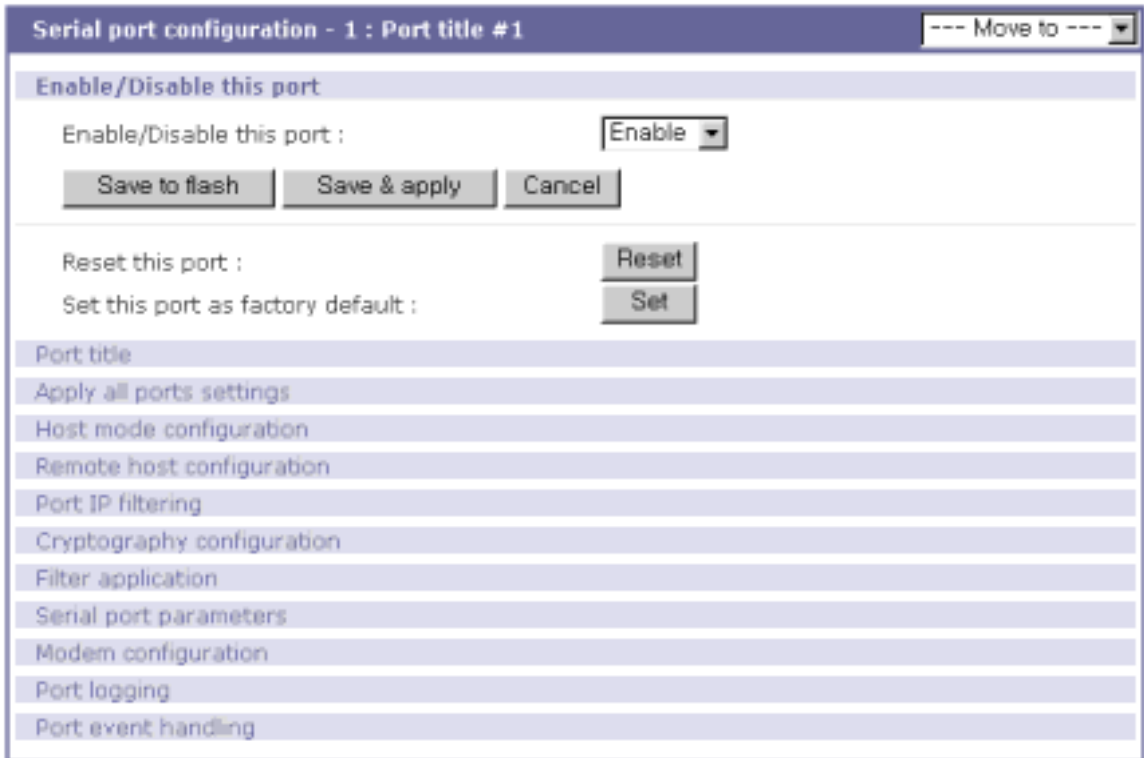

4-2 Serial port enable/disable

### 4.2.1. Port Enable/Disable

enable

disable

4-2

가 disable 가  
enable/disable

stuck  
this port as factory default]

[Reset this port]  
[Set]

[Reset]

, [Set

### 4.2.2. Port Title

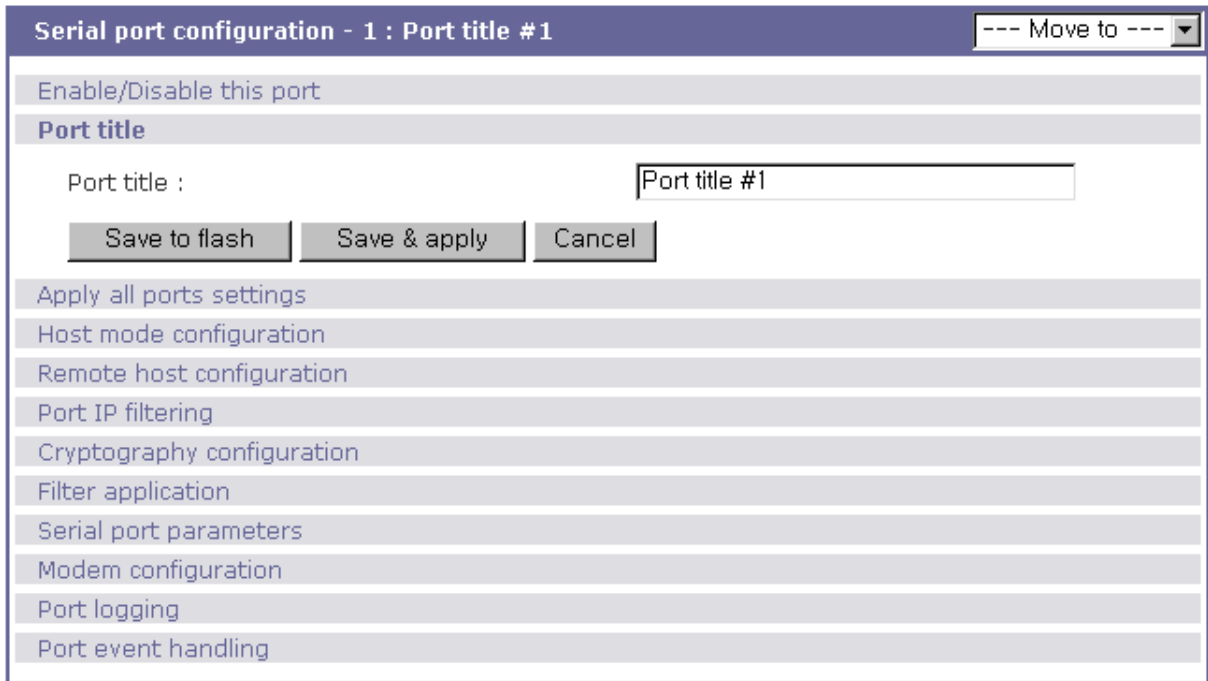

4-3 Port title configuration

### 4.2.3. Apply All Port Settings

가 all ports settings

가,

, Super

disable

all ports setting

.

4-4 apply all ports settings



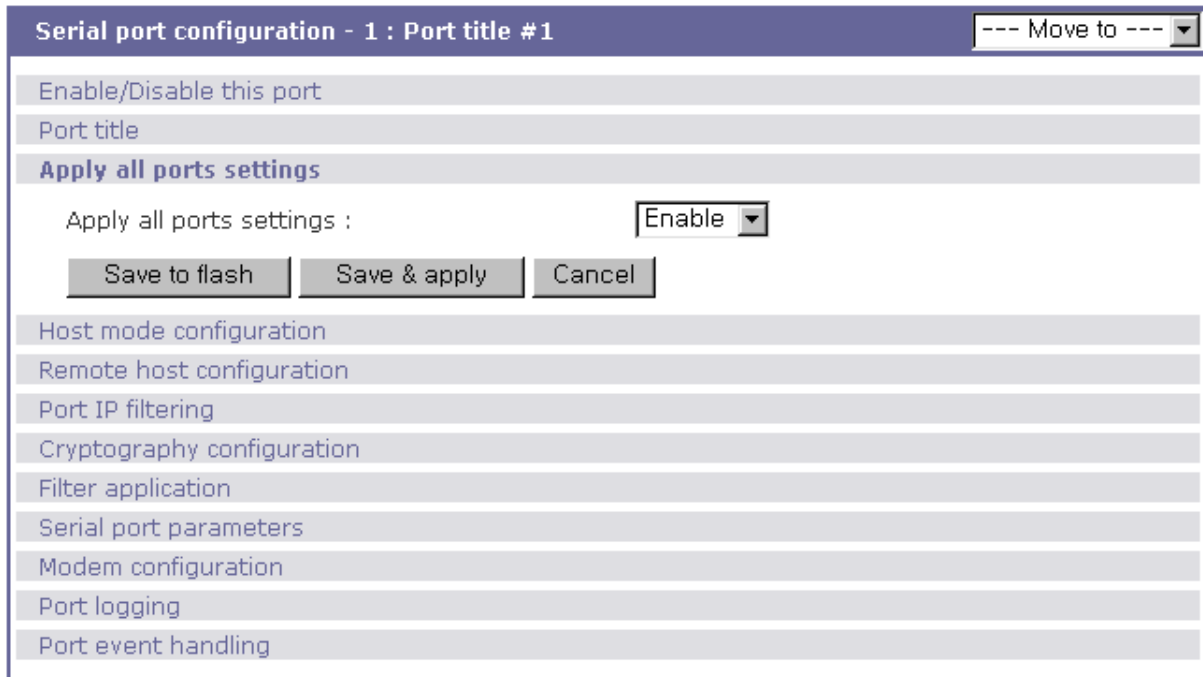

4-4 Apply all port setting configuration.

#### 4.2.4.

Super " " . TCP , UDP ,  
가 가 .

#### TCP

TCP ,  
TCP . TCP TCP Super  
Super 가  
TCP .

#### UDP

UDP UDP TCP

가 AT 가 AT  
. TCP .

4-5 .

Serial port configuration - 1 : Port #1 --- Move to --- ▾

Enable/Disable this port

Port title

Apply all ports settings

**Host mode configuration**

Host mode :

TCP listening port (1024-65535, 0 for only outgoing connections) :

Telnet protocol :

Max. allowed connection (1-32) :

Cyclic connection to remote hosts (sec, 0 : disable) :

Inactivity disconnection timeout (sec, 0 : unlimited) :

Remote host configuration

Port IP filtering

Cryptography configuration

Filter application

Serial port parameters

Modem configuration

Port logging

Port event handling

4-5

#### 4.2.4.1. TCP

TCP

(State Transition Diagram)

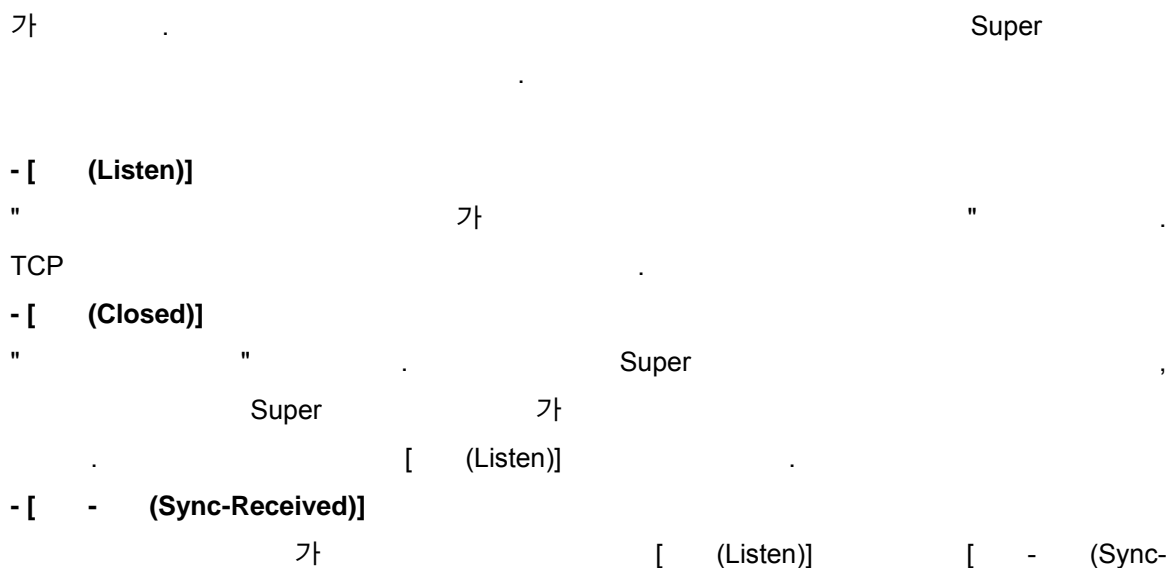

Received)] Super 가 , [ (Established)]

- [ (Sync-Sent)]

Super 가 [ (Closed)] [ (Sync-Sent)] 가

- [ (Established)]

" (open connection)" Super 가 [ (Established)]

- [ (Data)]

[ (Established)] TCP

[ (Data)] , [ (Data)] RFC 793 [TCP: Transmission Control Protocol] [ (Established)] 가

Super TCP Super TCP TCP [ (Listen)] 가

1)

[ (Listen)] --> [ (Sync-Received)] --> [ (Established)] --> [ (Data)] --> [ (Closed)] --> [ (Listen)]

Or

[ (Listen)] --> [ (Sync-Sent)] --> [ (Established)] --> [ (Data)] --> [ (Closed)] --> [ (Listen)]

[ (Listen)] 가 TCP TCP Super 가 가

2)

Super 가 0 Super Super

가 Super  
 Super  
 가 , 1  
 2  
 10 가  
 " (Inactivity timeout)" (Options) ( 4.4

3)

TCP

가 TCP TCP  
 TCP  
 Super 1024 66635 0 가  
 (outgoing connection) (TCP )

TCP , Super COM (RFC2217 )  
 (baud rate),  
 RFC2217  
 ( 4.2.9 )

RFC2217 COM Super  
 , Tactical Software Serial/IP 가 COM  
 Serial/IP ( )  
 6 Serial/IP Super )

Super 32 .  
 (remote host list configuration)  
 , 가 ( - 32 ,  
 ) 가 Super 3  
 29(=32 - 3)  
 4.2.5

(Cyclic Connection) Super  
 가 , 가 ,  
 Super Super  
 Super 가 , Super ,  
 가 Super 가 Super  
 가 Super 가 Super  
 4-6 TCP

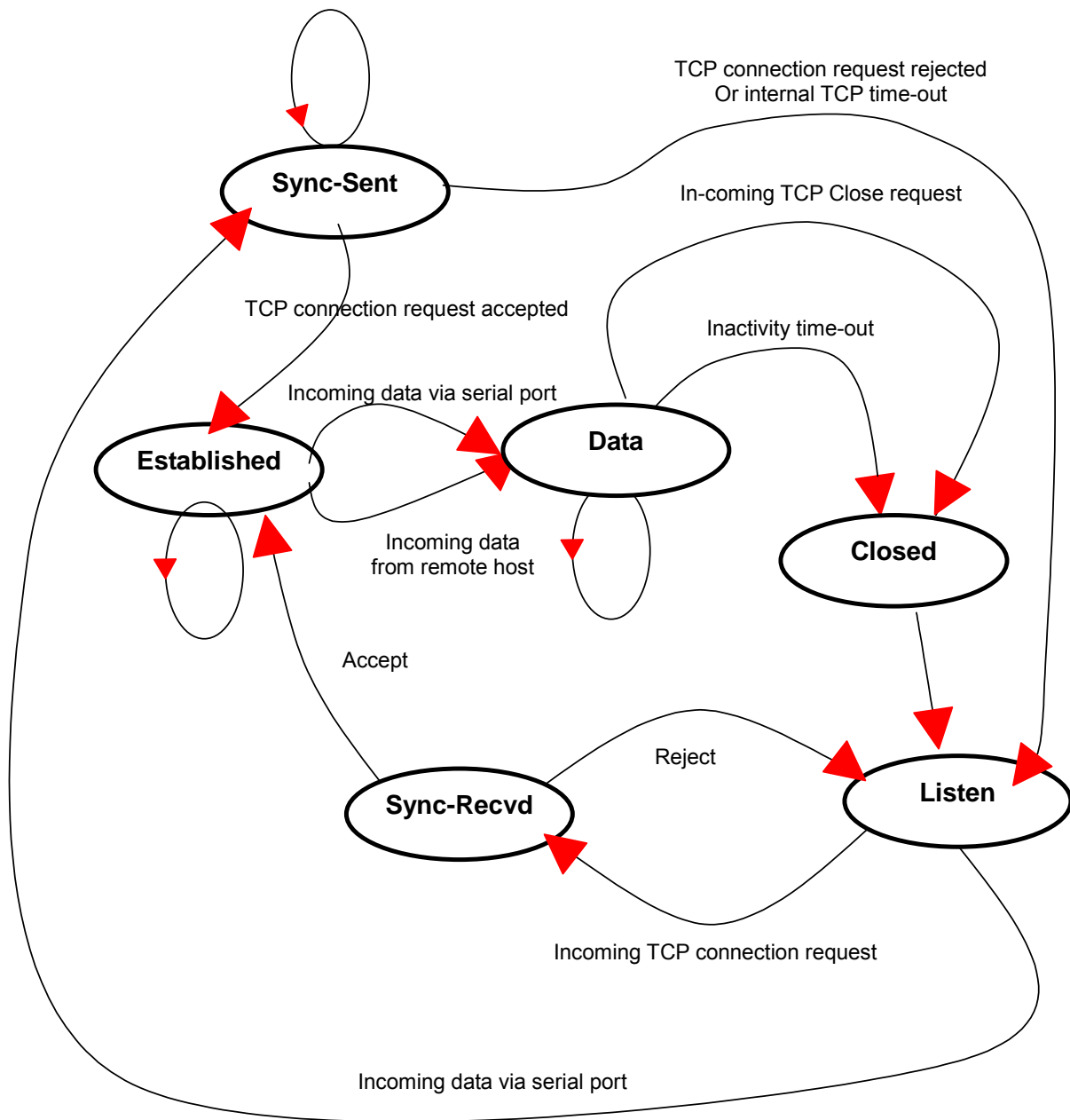

4-6 TCP

**(Inactivity Timeout)**

(Inactivity Timeout)

Super

#### 4.2.4.2. UDP

UDP UDP TCP UDP Super

가 .

1)

가 UDP Super UDP ,

Super . 가 ,

Super Super

UDP . ' (Yes)'

UDP datagram (Accept UDP datagram from unlisted remote host)' ' (Yes)'

UDP Super 가

가 , Super

(Send to recent unlisted remote host)' ' (Yes)' ,

( ) Super

2)

UDP  
TCP

4.2.4.1 TCP

TCP 4.2.4.1 TCP

UDP

' UDP datagram (Accept UDP datagram from unlisted remote host)' ' (No)' , Super

UDP

' UDP datagram (Accept UDP datagram from unlisted remote host)' ' (Yes)' , Super

UDP

' (Yes)' , Super (Send to recent unlisted remote host)'  
 Super  
 Super  
 Super  
 Super (Inactivity Timeout)  
 Super  
 UDP , Super  
 Super , Super  
 Super 가 , UDP  
 Super 가 0 , Super . UDP

4.2.4.3.

, AT  
 Super Ethernet  
 Super IP ( ) 가 ATA/ATDT  
 가  
 ATD(T) XXX IP ( ) 가



Super

Ethernet

4-2

Super

AT

4-7

Ethernet

ATDA

4-2 Super

AT

		9 (verbose code)	
+++			
ATD(T) [ IP ]:[ ] [CR][LF]	TCP TCP ) atdt192.168.1.9:1002: IP 192.168.1.9, 1002 ) atdt	CONNECT [CR][LF] NO CARRIER [CR][LF] 가 ERROR [CR][LF]	
AT ATZ [CR][LF]	TCP	OK [CR][LF] ERROR [CR][LF] OK [CR][LF] ERROR [CR][LF]	
ATA [CR][LF]			
ATA [ ] [CR][LF]	TCP TCP TCP [ (Listen)] TCP 가 TCP 가		
ATEn [CR][LF]	E, E0: E1:		
ATHn [CR][LF]	H, H0, H1: TCP 가		
ATOn [CR][LF]	O, O0:		
ATQn [CR][LF]	Q, Q0: ( ) Q1:		
ATVn [CR][LF]	V, V0: = <numeric code> [CR][LF] V1 ( ): = <verbose code> [CR][LF]		
AT&Dn [CR][LF]	D, D0: DTR(PC) D2( ): TCP		
AT&Fn [CR][LF]	F, F0, F1:		
AT&Kn [CR][LF]	K, K0: 가 K3: RTS/CTS ( ) K4: Xon/Xoff ( )		
AT&Sn [CR][LF]	S, S0: DSR(PC) S1: DSR(PC)가 TCP		
ATIn [CR][LF]	I, I0 : "Sena Technologies, Inc." I3 : : "OK"		<=

9 가

AT\Tn [CR][LF]	\T, \T0: n . ( )	OK [CR][LF]
ATBn, ATCn, ATLn, ATMn, ATNn, ATP, ATT, ATYn, AT%Cn, AT%En, AT&Bn, AT&Gn, AT&In, AT&Qn, AT&V, ATjMn, AT\An, AT\Bn, AT\Nn		OK [CR][LF]
ATS?, ATSn=x, AT&Cn, AT&Wn, AT&Zn=x		ERROR [CR][LF]
ATFn [CR][LF]		n 1 OK [CR][LF] ERROR [CR][LF]
ATWn, ATXn		n 0 OK [CR][LF] ERROR [CR][LF]

4-3 AT

(Verbose Code) ("ATV1")	(Numeric Code) ("ATV0")	
OK	0	
CONNECT	1	
RING	2	가
NO CARRIER	3	
ERROR	4	

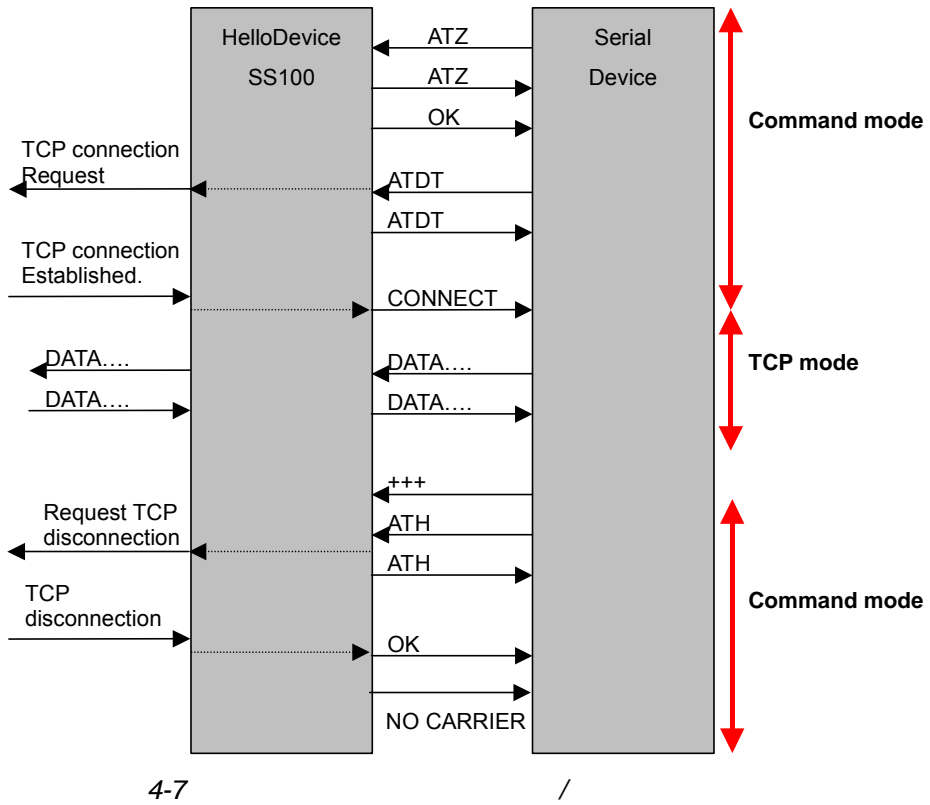

4.2.5.

(Remote Host Configuration) Super

Super

TCP , Super 가 1

2 . 1

, Super 1 2

. 1

16 .

UDP Super 가 1

1 . 2 가 .

4-8 . (TCP )

Serial port configuration - 1 : Port Title #1 --- Move to --- ▾

Enable/Disable this port

Port title

Apply all ports settings

Host mode configuration

**Remote host configuration**

Check	Host #	Primary remote host IP	Port #	Secondary remote host IP	Port #
<input type="checkbox"/>	1	192.168.14.1	6001	192.168.13.1	5001
<input type="checkbox"/>	2	192.168.14.2	6002	192.168.13.2	5002

Action on remote host :  Add  Edit  Remove

Primary host address :

Primary host port :

Secondary host address :

Secondary host port :

Port IP filtering

Cryptography configuration

Filter application

Serial port parameters

Modem configuration

Port logging

Port event handling

4-8

#### 4.2.6. Port IP filtering

Super IP filtering 가 Super  
 IP subnet mask 3.5

Serial port configuration - 1 : Port title #1 --- Move to --- ▾

Enable/Disable this port

Port title

Apply all ports settings

Host mode configuration

Remote host configuration

**Port IP filtering**

Allowed host IP :

Subnet mask to be applied :

Cryptography configuration

Filter application

Serial port parameters

Modem configuration

Port logging

Port event handling

4-9 Port IP filtering for serial ports

#### 4.2.7.

Super (UDP ) TCP

##### 4.2.7.1. Secure Sockets Layer(SSL) Transport Layer Security(TLS)

By setting the cryptography method as one of SSLv2, SSLv3, SSLv3 rollback to v2 or TLSv1, the Super 가 SSL/TLS

SSL Netscape . SSL

HTTP

. SSL , 가

. SSL . SSL

TCP/IP

TLS SSL . Internet Engineering Task Force (IETF)

Internet RFC . TLS SSL

가 , SSL 가

. TLS

SSL/TLS

SSL

- 1. SSL/TLS (symmetric key) 가 SSL/TLS (cipher) 가
- 2. 가 SSL/TLS (cipher) 가 SSL/TLS 가
- 3. 가 가
- 4. premaster secret ( chipher) 가 SSL/TLS
- 5. 가 ( ) 가 premaster secret
- 6. 가 (private key) premaster secret (master secret) 가
- 7. SSL/TLS (session key) SSL/TLS
- 8. (integrity)

9.

10. SSL/TLS

가

SSL/TLS

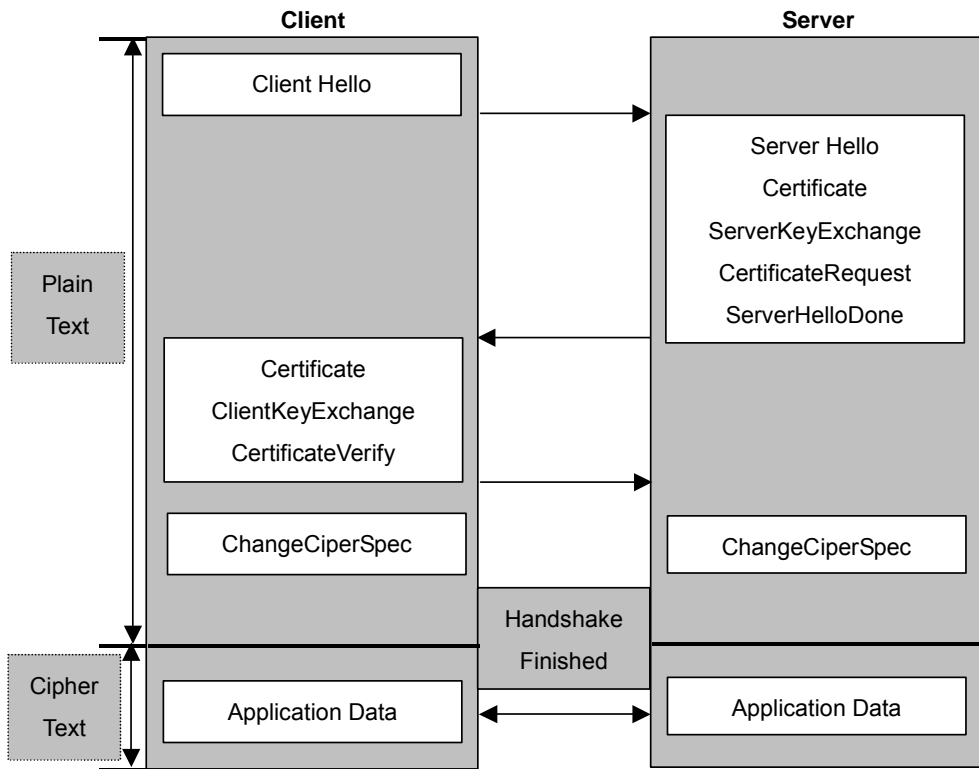

4-10 SSL/TLS

Super TCP SSL/TLS , Super SSL  
 SSL/TLS TCP , SSL/TLS TCP Super  
 SSL/TLS , SSL/TLS TCP Super SSL/TLS  
 Super SSL Super SSL/TLS

가 SSL/TLS

- (Cipher suites) /**

Cipher suites SSL/TLS (asymmetric), (symmetric)

(hash)

( ) (identity)

SSL/TLS

가

가 SSL/TLS 가 cipher suite

cipher suite

가 cipher suite

cipher suite RSA

cipher suite 가 cipher suite

Super cipher suite cipher suite

- ( )**

가 “ ” , Super SSL

( 2) 가

“ ” , Super SSL ( 2)

- (certificate chain depth)**

가 ,

( (peer))

CA CA (peer)

가 CA ,

가

Super

Super 가 CA

- CN**

가 CN “ ” , Super

CN( ) Super

가 CN

“ ” , Super CN( )



Super

SSL/TLS

CN( )

Serial port configuration - 1 : Port title #1 --- Move to --- ▾

Enable/Disable this port

Port title

Apply all ports settings

Host mode configuration

Remote host configuration

Port IP filtering

**Cryptography configuration**

Encryption method : SSLv2 ▾

Enable/Disable cipher suites :

- SSL\_CK\_RC4\_128\_WITH\_MD5
- SSL\_CK\_RC4\_128\_EXPORT40\_WITH\_MD5
- SSL\_CK\_RC2\_128\_CBC\_WITH\_MD5
- SSL\_CK\_RC2\_128\_CBC\_EXPORT40\_WITH\_MD5
- SSL\_CK\_IDEA\_128\_WITH\_MD5
- SSL\_CK\_DES\_64\_CBC\_WITH\_MD5
- SSL\_CK\_DES\_192\_EDE\_CBC\_WITH\_MD5

Verify client (int server mode only) : NO ▾

Verify certificate chain depth : 0

Check the certificate CN : NO ▾

Save to flash Save & apply Cancel

Filter application

Serial port parameters

Modem configuration

Port logging

Port event handling

4-11

#### 4.2.7.2. 3DES

3DES

Super

3DES(168 bits)

Super

HelloDevice Super

4.12 3DES



4-12 3DES

- 8-bits (cipher) ( ) 3DES 64 8(64/8)

- (Padding) (cipher) (1~8)

Super 3DES 4-13

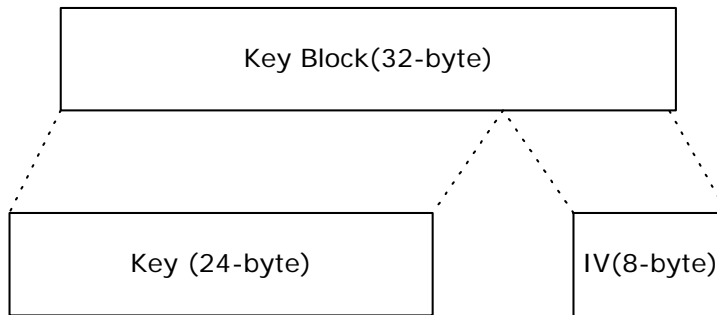

4-13

$$\text{Key\_Block} = \text{MD5}(\text{KEY\_STRING}) + \text{MD5}(\text{MD5}(\text{KEY\_STRING}) + \text{KEY\_STRING})$$

$$= (16 \text{ bytes}) + (16 \text{ bytes})$$

$$\text{Key} = 24\text{bytes}$$

$$\text{IV(Initial Vector)} = \text{Bytes}$$

### 4.2.7.3. RC4

RC4 Super RC4 Super  
 TCP RC4 Super RC4  
 RC4 3DES 가

#### 4.2.8.

Super

가

가

Super

9.4

6.9

Serial port configuration - 1 : Port Title #1

--- Move to ---

Enable/Disable this port

Port title

Apply all ports settings

Host mode configuration

Remote host configuration

Port IP filtering

Cryptography configuration

**Filter application**

Filter application path : /usr2/default\_filter

Filter application arguments : -p0

Save to flash Save & apply Cancel

Serial port parameters

Modem configuration

Port logging

Port event handling

4-14

#### 4.2.9.

Super

가

UART

(baud rate), , , , DTR/DSR  
(inter-character)

67

- **UART type**

Super

RS232, RS422, RS485(echo)

RS485(non-echo)

B

Super

echo

non-echo

가

RS485

2 (two-wire)

RS485 echo

non-echo

1

- **(Baud rate)**

Super

75, 150, 200, 300, 600, 1200, 2400, 4800, 9600, 14400, 19200, 38400, 57600, 115200, 230400

9600

- **(Data bits)**

7 bits

8 bits

8 bits

**Serial port configuration - 1 : Port #1** --- Move to --- ▾

Enable/Disable this port

Port title

Apply all ports settings

Host mode configuration

Remote host configuration

Port IP filtering

Cryptography configuration

Filter application

**Serial port parameters**

Type :  ▾

Baud rate :  ▾

Data bits :  ▾

Parity :  ▾

Stop bits :  ▾

Flow control :  ▾

DTR behavior :  ▾

DSR behavior :  ▾

Inter character time-out (0-10000 msec) :

Modem configuration

Port logging

Port event handling

4-15 UART

- **(Parity)**  

none, even	odd	none
------------	-----	------
  
- **(Stop bits)**  

1 bit	2 bit	1 bit
-------	-------	-------
  
- **(Flow control)**  

RTS/CTS	None	Super XON/XOFF
		(XON/XOFF(0x11/0x13))

:  
 RS232 . RS422 RS485

● **DTR/DSR**

DTR/DSR TCP  
 . DTR (write-only)

DSR (read-only)

DTR :

Always high

Always low

High when open

TCP

. UDP

UDP

(Remote Host)가

가

DTR 가

DSR

None

DSR 가

Allow TCP connection only by high

DSR 가

, TCP가

. DSR

가

TCP

UDP

, TCP

. DSR 가

. Super

DTR

Super

TCP

● **(Inter-character )**

TCP/UDP

. Super

가

가

TCP/UDP

가 1024 bytes

1024bytes

TCP/UDP

'0'

Super

가

bps, 8

, 1

(no parity)

가 1200

bit                    10bit  
 $10 \text{ (bits)} / 1200 \text{ (bits/s)} * 1000 \text{ (ms/s)} = 8.3 \text{ ms}$   
 8.3ms                    8.3ms                    , 0  
 (ms)

#### 4.2.10.

Super                    가  
 DCD                    init-string  
 Super                    가 TCP

- /  
 Super                    Super  
 DTR/DSR/DCD                    가

- **init-string**  
*Modem init-string*                    (initialization string)  
*Enable/Disable modem*                    (Enabled)  
 Super                    DTR                    가  
 가                    가

- **DCD**  
 DCD                    'TCP                    (Allow TCP connection only by HIGH)'  
 , Super                    DCD                    가  
 가                    (dial-in modem mode)  
 Super  
 TCP                    TCP  
 가                    (dial-out)                    ,                    DCD                    None  
 가

- Enable                    ,                    TCP                    Super  
 DSR                    가  
 Super                    DTR                    (

DSR)

TCP가

가

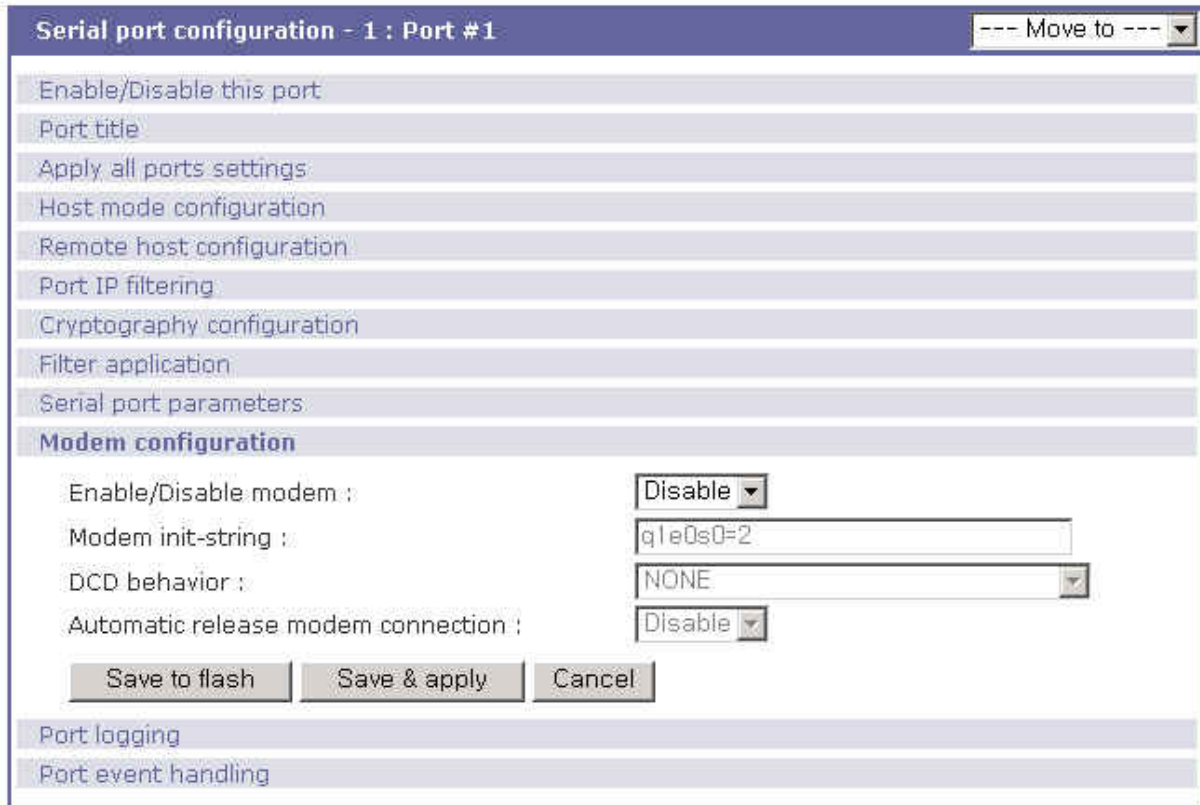

4-16

#### 4.2.11. (Port Logging)

MEMORY, ATA/IDE

, SYSLOG NFS

- / (Enable/disable)

(disabled)]

- Super , ATA/IDE (PCMCIA

), NFS SYSLOG

Super 가



ATA/IDE ,

SYSLOG NFS 가

가 3200 Kbytes .(

3200 Kbytes .)

4 Kbytes  
ATA/IDE

NFS 가 NFS 가

SYSLOG 가

Serial port configuration - 1 : port # #1 --- Move to ---

Enable/Disable this port

Port title

Apply all ports settings

Host mode configuration

Remote host configuration

Port IP filtering

Cryptography configuration

Filter application

Serial port parameters

Modem configuration

**Port logging**

Port logging : Enable

Port log storage location : Memory

Port log buffer size (KB, 400 max.) :

Port log :

Port event handling

4-17 Port logging configuration

**4.2.12.**

Super 가

email/SNMP (notification) 가

가

/ Super

Super TCP

(reaction) email

, SNMP ,

- 가 , (enable) Super (disable)

- (Notification interval)**  
Super email SNMP 가  
email SNMP , email SNMP  
가 , Super ,  
가  
가  
:

- Email (Email notification)**  
Super Email Super  
Email SMTP SMTP SMTP  
가 Email  
SMTP 3.4 SMTP

- Email**  
가 Super Email

- Email**  
가

- SNMP**  
Super SNMP

- SNMP**  
가 Super SNMP

Serial port configuration - 1 : Port title #1
--- Move to --- ▾

---

Enable/Disable this port

Port title

Apply all ports settings

Host mode configuration

Remote host configuration

Port IP filtering

Cryptography configuration

Filter application

Serial port parameters

Modem configuration

Port logging

**Port event handling**

Port event handling : Enable ▾

Notification interval (30-3600 sec) :

Email notification : Enable ▾

Title of Email :

Recipient's Email address :

SNMP notification : Disable ▾

Title of SNMP trap :

SNMP trap receiver IP :

SNMP trap community :

SNMP trap version : V1 ▾

**[Status event edit]**

Status event	Email Noti.	SNMP trap Noti.	Port command	Port command string
Device connection	<input checked="" type="checkbox"/>	<input checked="" type="checkbox"/>	<input type="checkbox"/>	<input type="text"/>
Device disconnection	<input checked="" type="checkbox"/>	<input checked="" type="checkbox"/>	<input type="checkbox"/>	<input type="text"/>
TCP connection	<input checked="" type="checkbox"/>	<input type="checkbox"/>	<input type="checkbox"/>	<input type="text"/>
TCP disconnection	<input checked="" type="checkbox"/>	<input type="checkbox"/>	<input type="checkbox"/>	<input type="text"/>

**[Keyword list edit]**

Action on key word :  Add  Edit  Remove

Keyword string	Email Noti.	SNMP trap Noti.	Port command	Port command string
<input type="text"/>	<input checked="" type="checkbox"/>	<input type="checkbox"/>	<input checked="" type="checkbox"/>	<input type="text"/>

- **SNMP** IP(SNMP trap receiver IP)  
가 SNMP SNMP  
IP

- **SNMP** (SNMP trap community)  
가 SNMP

- **SNMP** (SNMP trap version)  
가 SNMP

[ ]

- /

- **TCP** /  
TCP

[ ]

- “ 가” “ ”

- (Keyword string)

- **Email**  
가 Email

- **SNMP** (SNMP trap notification)  
가 SNMP

- **Port**  
가

- **Port** (Port command string)

Super

가

### 4.3.

가 , . **All port configuration** “**apply all port setting**” **disable** . (SS100/110 all port configuration 가 .)

#### “all port configuration” :

1. Port enable/disable
2. Port title
3. Host mode
4. Remote host configuration
5. Port IP filtering
6. Cryptography configuration (*Only valid and visible if host mode set to TCP or Modem Emulation mode*)
7. Filter application
8. Serial port parameters
9. Modem configuration (*Only valid and visible if host mode set to TCP mode*)
10. Port logging
11. Port event handling

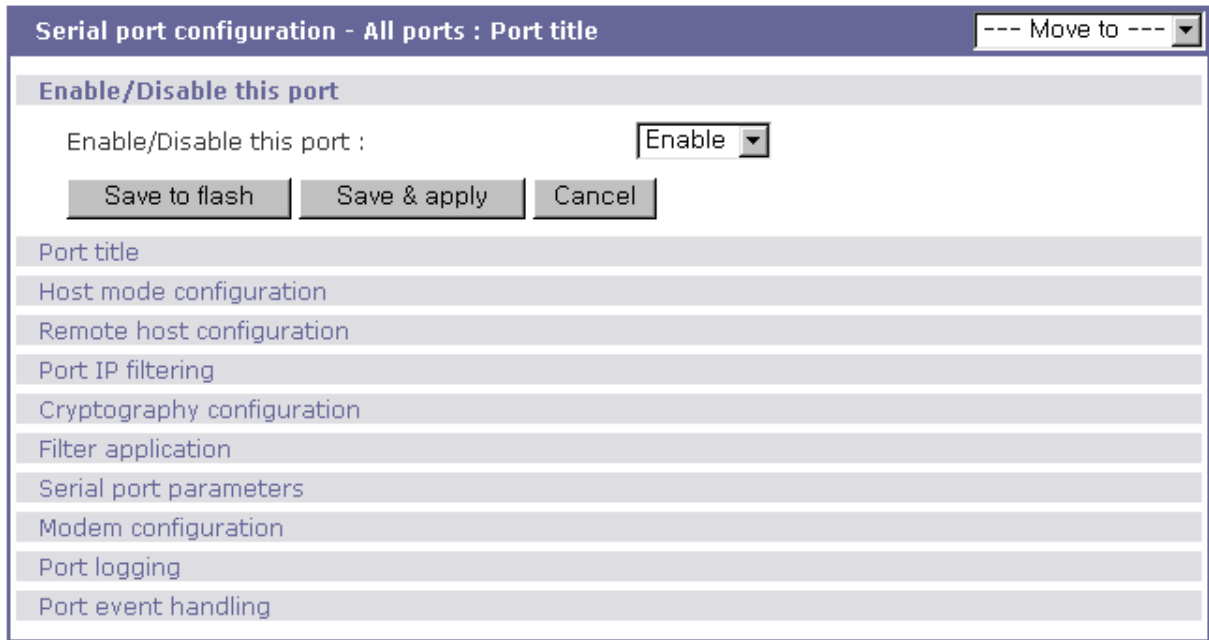

Figure 4-19

- **Port enable/disable**

- **Port title**

가 , " my server "

#1 " my server#1 " #2 " my server#2 "

- **Host mode**

가 TCP UDP , (listening)

가

*(listening port number + serial port number - 1)*

"all port configuration" value set

- **Remote host configuration, Port IP filtering, Cryptography configuration, Filter application, Serial port parameters, Modem configuration, Port logging, Port event handling**

, "all port configuration" values set

# 5. PC

Super PC 가 . 4가

- LAN
- LAN
- 
- ATA/IDE fixed disk card

: SS100 PC

LAN LAN Super  
 , ATA/IDE fixed disk card

(out-of-band) Super

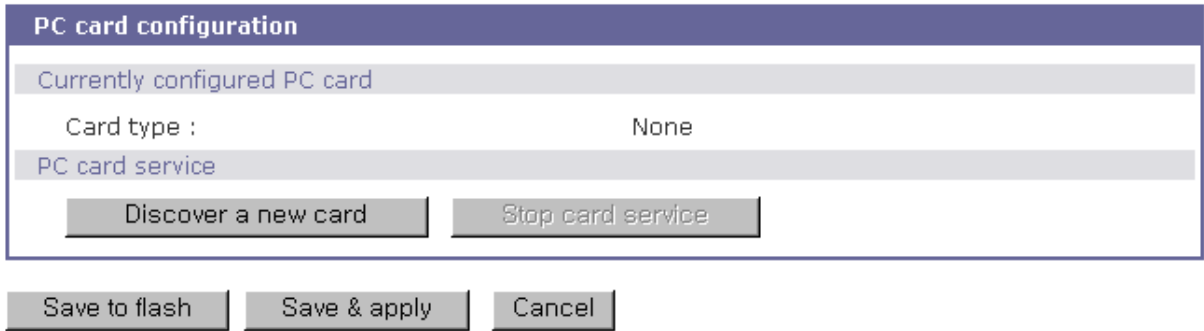



Figure 5-1 PC

PC

1. PC PC
2. Select PC 
3. Super (plug & play)
4. Save the configuration settings by selecting 
5. [Apply changes]

Super 가 PC 가





5-2

Super 가 PC B. PC

PC

Step 1. [(Ban- show the actual button) Stop card service]

Step 2. [Save to flash]

Step 3. [Apply changes]

Step 4. PC PC

: PC

## 5.1.

LAN PC Super 2 IP

, IP

PC card configuration	
Currently configured PC card	
Card type :	Network Card
Model :	Linksys EtherFast 10/100 Integrated PC Card (PCM100) Ver 1.0
Network configuration	
IP mode :	<input type="text" value="DHCP"/>
IP address :	<input type="text" value="192.168.1.254"/>
Subnet mask :	<input type="text" value="255.255.255.0"/>
Default gateway :	<input type="text" value="192.168.1.1"/>
Primary DNS :	168.126.63.1
Secondary DNS :	168.126.63.2
PPPoE user name :	<input type="text" value="whoever"/>
PPPoE password :	<input type="password" value="*****"/>
Confirm PPPoE password :	<input type="password" value="*****"/>
PC card service	
<input type="button" value="Discover a new card"/> <input type="button" value="Stop card service"/>	
<input type="button" value="Save to flash"/> <input type="button" value="Save &amp; apply"/> <input type="button" value="Cancel"/>	

5-3 PC LAN



PC

primary secondary DNS  
3.1 IP

Super Privacy)	LAN	SSID(Service Set Identifier) AP (Access Point)	WEP(Wired Equivalent SSID)
, encrypted	shared	WEP	WEP
40 128 bit	40-bit WEP	(:)	5 16
	128-bit WEP	(:)	13 16
, 128-bit WEP			13 16
		000F25E4C2000F25E4C2000F24	

Super 가  
PC

PC

B. Super 가

### 5.3. Serial Modem

가 . 56 Kbps 가 Super 가  
PC B. Super 가 PC .

**PC card configuration**

Currently configured PC card

Card type : Serial Modem Card Serial Modem Card  
 Model : PCMCIA CARD 56KFaxModem FM56C-NFS 5.41

PC card service

Discover a new card Stop card service

Save to flash Save & apply Cancel

5-5 PC serial modem

## 5.4. ATA/IDE Fixed Disk Card Configuration

PC ATA/IDE fixed disk card

가

Delete

Format

EXT2 VFAT

Super export import Super

**PC card configuration**

Currently configured PC card

Card type :	ATA/IDE Fixed Disk Card
Model :	TOSHIBA THNCF064MBA
Size :	64 MB
File system :	ext2

ATA/IDE Fixed Disk Card configuration

Total data size to be used (0~64 MB) :

Delete all files in ATA/IDE Fixed Disk Card :

Format ATA/IDE Fixed Disk Card :

PC card service

5-6 PC ATA/IDE fixed disk card

## 6.

Super

(Status Display Screen)

Super  
logging  
Super  
email  
Super  
system  
Super

### 6.1.

System status	
System information	
Model No. :	SS800 Device
Serial No. :	SS800-030799999
F/W Rev. :	v0.4.0
MAC address :	00-01-95-04-19-5a
Current time :	07/23/2003 13:40:42
System logging :	Enabled
Send system log by email :	Disabled
PC card type:	NONE
PC card model :	NONE
IP information	
IP mode :	STATIC
IP expiration :	N/A
IP address :	192.168.14.7
Subnetmask :	255.255.0.0
Gateway :	192.168.1.1
Receive/Transmit errors :	N/A
Primary DNS :	168.126.63.1
Secondary DNS :	168.126.63.2

## 6.2.

Super system logging  
system logging enable disable 가 ,

### System log storage location

Super , PC ATA/IDE fixed disk card,  
NFS SYSLOG  
Super 가  
ATA/IDE fixed disk card, SYSLOG  
NFS 가 ,

### System log buffer size

300 Kbytes  
ATA/IDE fixed disk card  
NFS  
NFS  
가  
Super 가  
email  
email  
email 6-2

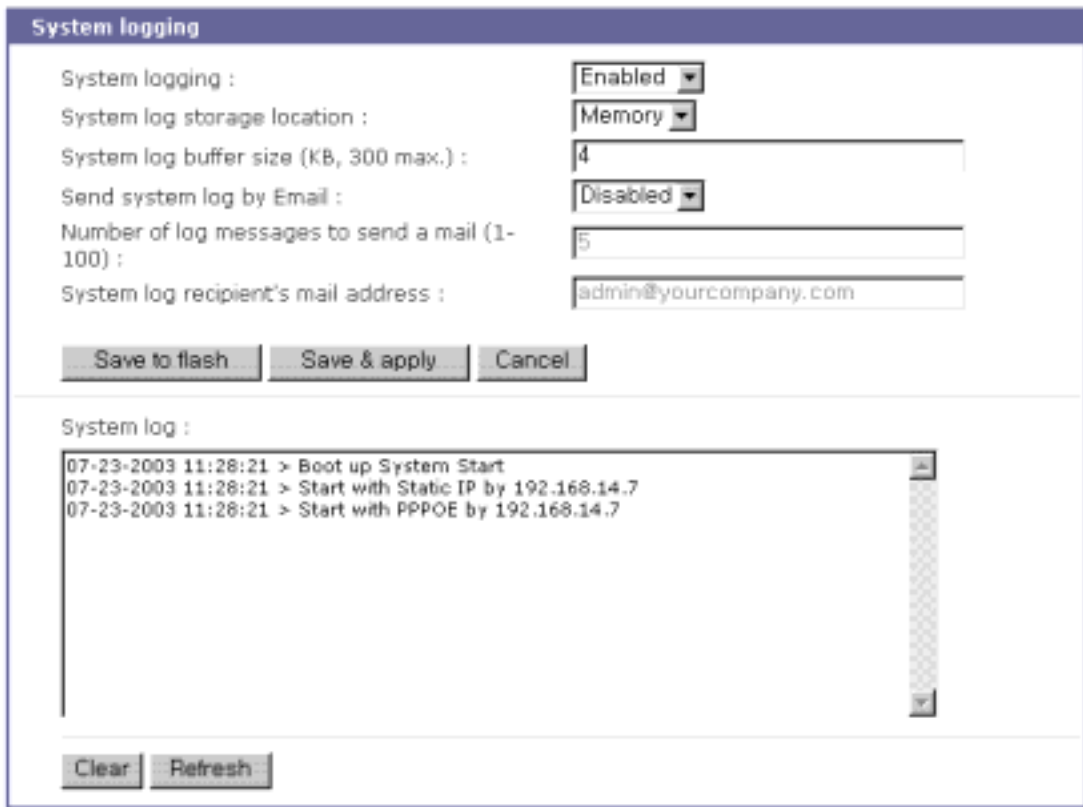

6-2

### 6.3.

Users logged on list			
Username	Terminal	Login Date and Time	From
root	console	Jul 23 11:27	

6-3

#### Users logged on list

User name( )  
 Terminal type for the session ( )  
 Time connected ( )  
 IP address of the remote host ( IP )

:

. HTTP/HTTPS

## 6.4.

6-4

**Change password**

Current username :	admin
Enter current password :	<input type="text"/>
Enter new password :	<input type="text"/>
Confirm new password :	<input type="text"/>

6-4

## 6.5. (Device name)

Super

9-4

가 Device name

Super

hostname

CLI

hostname

```
root@SS800_Device:~#
```

**Device name**

Device name :	<input type="text" value="SS800_Device"/>
---------------	---

6-5

Super

Device name

가 Device name

Super

hostname

Super

IP

Device name HelloDevice Manager



## 6.6.

Super . SS110/400/800  
(SS100 가 .  
NTP SS100  
6-6 .)  
가 NTP  
. NTP , Super  
NTP 가 . NTP 0.0.0.0 ,  
Super NTP Super  
(UTC: Universal  
Time Coordinated) NTP  
가 (timezone)  
UTC 가  
, UTC ,  
가 Super

Date and time	
Use NTP :	Disabled ▾
NTP server (0.0.0.0 for Auto) :	192.168.200.100
Date [mm/dd/yyyy] :	01/09/2004
Time [hh:mm:ss] :	11:09:20
<b>[Standard time]</b>	
Timezone :	UTC
Time offset from UTC (UTC + [x.x]hours) :	0.0
<b>[Daylight saving time]</b>	
Enable/Disable daylight saving time :	Disabled ▾
Daylight saving timezone :	
Time offset from UTC (UTC + [x.x]hours) :	0.0
Start date [mm/dd] :	01/00
Start time [hh:mm:ss] :	00:00:00
End date [mm/dd] :	01/00
End time [hh:mm:ss] :	00:00:00

6-6

## 6.7.

CF , NFS , (user space)  
 (Export) , CF , NFS ,  
 (Import) .  
 (Import) "Factory default" Super  
 . 6-7 . (Export)  
 (Import) .  
**(Configuration export)**  
**(Location) :** (Export) .  
**(Encrypt) :** Yes No.  
**(File name)**

**(Configuration import)**

**(Location) :** (Import) . **Factory default**

**(Configuration selection) :** (Import)

**(Encrypt) :** Yes No. (Import) 가 **Factory default**

**(File selection) :** CF , NFS ,  
(Export)

**(Local) :** 가 (Export)

The screenshot shows a 'Configuration management' window with two main sections: 'Configuration export' and 'Configuration import'.  
In the 'Configuration export' section, 'Location' has radio buttons for 'CF Card', 'NFS server', 'User space(/usr2)', and 'Local machine'. 'Encrypt' is a dropdown menu set to 'Yes'. 'File name' is a text box containing '.syscm'. An 'Export' button is at the bottom.  
In the 'Configuration import' section, 'Location' has radio buttons for 'CF Card', 'NFS server', 'User space(/usr2)', 'Local machine', and 'Factory default'. 'Configuration selection' has checkboxes for 'Select all', 'System configuration ( Including IP configuration )', and 'Serial port configuration'. 'Encrypt' is a dropdown menu set to 'Yes'. 'File selection' is a dropdown menu with '----- Select file -----' and a '찾아보기...' button. 'Local' is a text box. An 'Import' button is at the bottom.

6-7

(Export)

1. (Export)

2.

3.

4. [Export]

(Export)

(Import)

1. (Import)
2. (Import)
- 3.
4. (Import) 가 **Factory default**  
(Import)
5. (Import) 가 (browse)  
(Import)
6. [Import]

## 6.8.

<http://www.sena.com/support/downloads/> Sena

6-8

- 1.
- 2.
- 3.

**Firmware upgrade**

Select the new firmware binary file

**This will take 5 minutes maximum**

6-8

TELENT/SSH

Z  
IP

- 1.
2. TELENT/SSH

- ( , Telnet SSH .)
3. 6-9 .
  4. 6-10 Z .
  5. 가 .
  6. , Super 6-11 .
- Super .

```
Login : admin
Password : *****
```

```
-----
Welcome to SS-800 configuration page
Current time: 07/23/2003 15:04:07 F/W REV.: v1.0.0
Serial No.: SS800438349-42944 MAC address: 00-01-95-04-19-5a
IP mode: Static IP IP address: 192.168.14.7
-----
```

```
Select menu:
1. Network configuration
2. Serial port configuration
3. PC Card configuration
4. System administration
5. Save changes
6. Exit without saving
7. Exit and apply changes
8. Exit and reboot
<Enter> Refresh
---> 4
```

```
-----
System administration
-----
```

```
Select menu:
1. System status
2. System logging
3. Device name: SS800 Device
4. Date and time
5. Change password
6. User file upload
7. Reload factory default settings
8. Reload factory default settings except IP settings
9. Firmware upgrade
<ESC> Back, <Enter> Refresh
--->9
```

```
Do you want to upgrade firmware? (y/n): y
Transfer firmware by zmodem using your terminal application.
To escape, press Ctrl+X
**B0ff000005b157
```

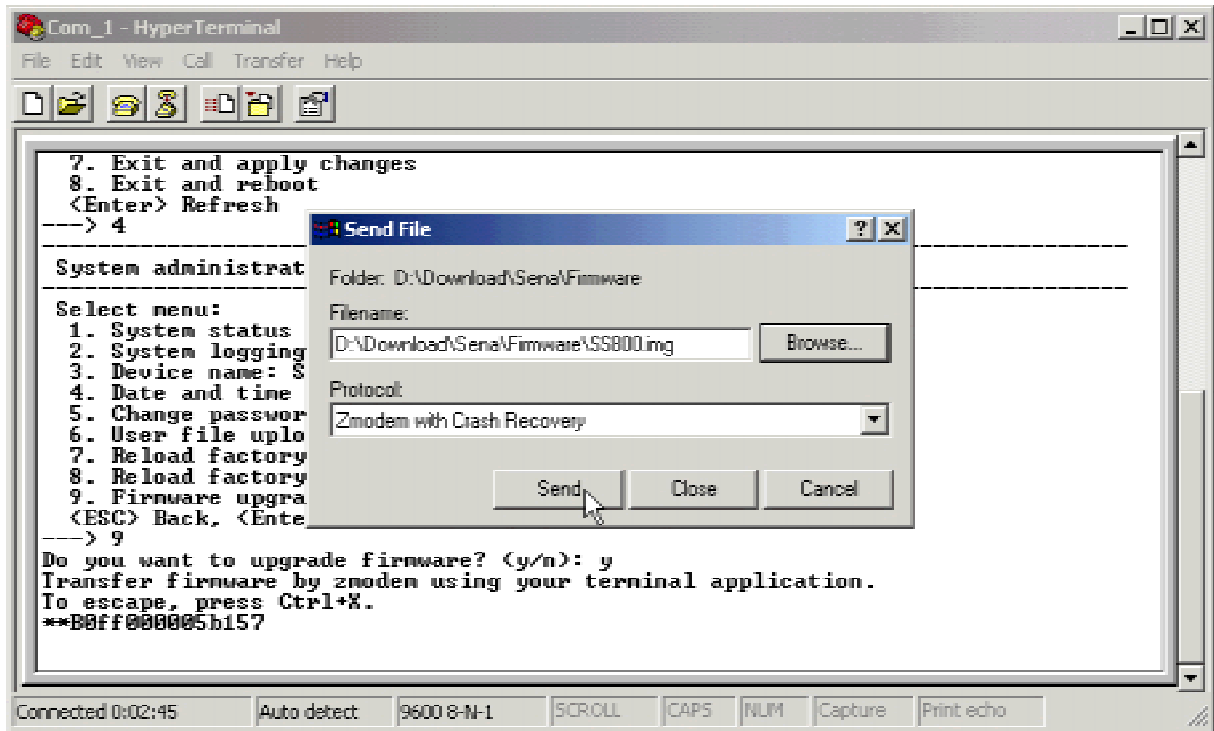

6-10 Z (HyperTerminal)

```

--->9
Do you want to upgrade firmware? (y/n): y
Transfer firmware by zmodem using your terminal application.
To escape, press Ctrl+X
**B0ff000005b157
**B0ff000005b157
**B0ff000005b157
**B0ff000005b157
Firmware upgrade failed !
Now reboot ...

```

6-11

## 6.9.

Super

6-12

"4.

System administration --> 6. User file upload"

가

Super

Z

TELNET/SSH

- 1.
2. TELNET/SSH

- ( , Telnet SSH  
.)
3. 6-12
  4. 6-10 Z
  5. 가 6-12
  6. Super 6-13
- (/usr2) Super  
, 8.2

```

-----
Welcome to SS-800 configuration page
Current time: 08/14/2003 11:56:13      F/W REV.   : v1.0.0
Serial No.   : SS800438349-42944      MAC address: 00-01-95-04-d3-03
IP mode     : DHCP                    IP address : 192.168.222.206
-----

Select menu:
 1. Network configuration
 2. Serial port configuration
 3. PC Card configuration
 4. System administration
 5. Save changes
 6. Exit without saving
 7. Exit and apply changes
 8. Exit and reboot
<Enter> Refresh
---> 4

-----
System administration
-----

Select menu:
 1. System status
 2. System logging
 3. Device name: SS800 Device
 4. Date and time
 5. Change password
 6. User file upload
 7. Reload factory default settings
 8. Reload factory default settings except IP settings
 9. Firmware upgrade
<ESC> Back, <Enter> Refresh
---> 6
Do you want to upload a file to user space? (y/n): y
Enter a filename: test.txt
The file will be saved as /usr2/test.txt.
Transfer a file by zmodem using your terminal application.
To escape, press Ctrl+X.
**B01ff000005b157

Uploading a file is completed.

```

6-12

```
Do you want to upload a file to user space? (y/n): y
Enter a filename: test.txt
The file will be saved as /usr2/test.txt.
Transfer a file by zmodem using your terminal application.
To escape, press Ctrl+X.
**B01ff000005b157
Uploading a file failed.
```

6-13



# 7.

Super

Super

link layer, **lo**, **eth**

. IP, ICMP, TCP    UDP    TCP/IP    4

## 7.1. (Network Interfaces)

Super    local loop back interface    **lo**    Super  
**eth0**



Network interfaces statistics			
Interface		lo	eth0
Receive	Bytes	680	7448861
	Packets	8	8057
	Errors	0	0
	Drop	0	0
	FIFO	0	0
	Frame	0	0
	Compressed	0	0
	Multicast	0	0
Transmit	Bytes	680	766794
	Packets	8	3991
	Errors	0	0
	Drop	0	0
	FIFO	0	0
	Frame	0	330
	Compressed	0	0
	Multicast	0	0

7-1

## 7.2.

32

, Baud rate

. (  : On     : Off )

Serial ports statistics									
Port	Baud Rate	Tx	Rx	RTS	CTS	DTR	DSR	CD	
1	38400	0	0	●	●	●	●	●	
2	38400	0	0	●	●	●	●	●	
3	38400	0	0	●	●	●	●	●	
4	38400	0	0	●	●	●	●	●	
5	38400	0	0	●	●	●	●	●	
6	38400	0	0	●	●	●	●	●	
7	38400	0	0	●	●	●	●	●	
8	38400	0	0	●	●	●	●	●	

7-2

### 7.3. IP

IP                    IP                    /

#### Forwarding :

IP forwarding    enable            disable

#### DefaultTTL :

TTL(Time To Live)

#### InReceives :

#### InHdrErrors :

가 (checksum), , TTL )

#### InAddrErrors :

가

#### ForwDatagrams :

Forwarding

#### InUnknownProtos :

#### InDiscard :

( , )

IP

#### InDelivers :

**OutRequests :**

. Forwarding

**OutDiscards :**

**OutNoRoutes :**

destination IP

가

**ReasmTimeout :**

가

,

가

**ReasmReqds :**

**ReasmOKs :**

**ReasmFails :**

**FragOKs :**

fragmentation

**FragFails :**

fragmentation

**FragCreates :**

fragment

IP statistics	
Forwarding	2
DefaultTTL	64
InReceives	8208
InHdrErrors	0
InAddrErrors	0
ForwDatagrams	0
InUnknownProtos	0
InDiscard	0
InDelivers	4892
OutRequests	4973
OutDiscards	0
OutNoRoutes	0
ReasmTimeout	0
ReasmReqds	4954
ReasmOKs	1667
ReasmFails	0
FragOKs	21
FragFails	0
FragCreates	118

7-3 IP

## 7.4. ICMP

ICMP                    ICMP

**InMsgs, OutMsgs :**

**InErrors, OutErrors :**

**InDestUnreachs, OutDestUnreachs :**

**InTimeExcds, OutTimeExcds :**

time-to-live(TTL)

**InParmProbs, OutParmProbs :**

가

**InSrcQuenchs, OutSrcQuenchs :**

Quench

**InRedirects, OutRedirects :**

Redirection

**InEchos, OutEchos :**

echo

**NEchoReps, OutEchoReps :**

echo

**InTimestamps, OutTimestamps :**

time-stamp

**InTimestampReps, OutTimestampReps :**

time-stamp

**InAddrMasks, OutAddrMasks :**

**InAddrMaskReps, OutAddrMaskReps :**

ICMP statistics	
InMsgs	4
InErrors	0
InDestUnreachs	4
InTimeExcds	0
InParmProbs	0
InSrcQuenchs	0
InRedirects	0
InEchos	0
InEchoReps	0
InTimestamps	0
InTimestampReps	0
InAddrMasks	0
InAddrMaskReps	0
OutMsgs	4
OutErrors	0
OutDestUnreachs	4
OutTimeExcds	0
OutParmProbs	0
OutSrcQuenchs	0
OutRedirects	0
OutEchos	0
OutEchoReps	0
OutTimestamps	0
OutTimestampReps	0
OutAddrMasks	0
OutAddrMaskReps	0

*7-4 ICMP*

## 7.5. TCP

TCP TCP

### RtoAlgorithm :

retransmission time-out (RTO)

가

0: CONSTANT - Constant Time-out

1: RSRE - MIL-STD-1778 B

2: VANJ - Van Jacobson's Algorithm

3: OTHER - Other

### RtoMin :

RTO (ms).

### RtoMax :

RTO (ms)

### MaxConn :

### ActiveOpens :

### PassiveOpens :

### AttemptFails :

### EstabResets :

### CurrEstab :

### InSegs :

segment

### OutSegs :

segment segment

### RetransSegs :

### RetransSegs :

### OutRsts :

Reset 가

TCP statistics		
RtoAlgorithm		0
RtoMin		0
RtoMax		0
MaxConn		0
ActiveOpens		0
PassiveOpens		0
AttemptFails		0
EstabResets		0
CurrEstab		2
InSegs		1051
OutSegs		1486
RetransSegs		0
InErrs		0
OutRsts		5

7-5 TCP

## 7.6. UDP

UDP

UDP

**InDatagrams :**

**NoPorts :**

가

**InErrors :**

**OutDatagrams :**

UDP statistics		
InDatagrams		3859
NoPorts		4
InErrors		0
OutDatagrams		3863

7-6 UDP

## 8. CLI

### 8.1.

<b>root</b>	<b>System admin</b>		Telnet/SSH		Super
Linux		(CLI)		. CLI	
Linux		Super			
	script		Super		
	Super		/	/usr2	1024 KB
				shell script	
<b>root</b>			Telnet/SSH		CLI
	System admin	CLI			

### 8.2.

Super				Mtdblock5	
	/usr2			/etc, /var	/tmp
			가	Super	
				saveconf	
		Super	가		
, Super	가				

Block	Type	Mount point	Size (KB)
Mtdblock0	Bootloader	None	128
Mtdblock1	Kernel	None	768
Mtdblock2	CRAMFS (Read only)	/	6080
Mtdblock3	Ram disk image (4MB)	/etc, /var, /tmp	64
Mtdblock4	EXT2 (R/W)	/cnf (normally unmounted)	64
Mtdblock5	JFFS2 (R/W)	/usr2	1024
Mtdblock6	Reserved	None	64
Total			8192



## 8.3. Linux

### 8.3.1. Shell shell utilities:

sh, ash, bash, echo, env, false, grep, more, sed, which, pwd

### 8.3.2. File disk utils:

ls, cp, mv, rm, mkdir, rmdir, ln, mknod, chmod, touch, sync,  
gunzip, gzip, zcat, tar, dd, df, du, find, cat, vi, tail,  
mkdosfs, mke2fs, e2fsck, fsck, mount, umount, scp

### 8.3.3. :

date, free, hostname, sleep, stty, uname, reset,  
insmod, rmmod, lsmod, modprobe,  
kill, killall, ps, halt, shutdown, poweroff, reboot, telinit, init,  
useradd, userdel, usermod, whoami, who, passwd, id, su, who

### 8.3.4. :

ifconfig, iptables, route, telnet, ftp, ssh, ping

## 8.4. root system admin CLI

- :
- 1) PC Super .
  - 2) PC .
  - 3) PC : 9600-8-N-1 No flow control
  - 4) <enter> .
  - 5) Super root admin .

Telnet :

- 1) telnet Super *\_ip\_address*

## 8.5. CLI Super

### 8.5.1. / :

- 1) Super , /cnf/cnf.tar.gz /tmp/cnf/  
/cnf/ unmount .
- 2) 가 , /tmp/cnf/ .
- 3) 가 [Save to flash], CLI saveconf ,  
 , Super /cnf mount /tmp/cnf/  
/cnf/cnf.tar.gz .

### 8.5.2. CLI :

CLI Super , configmenu

- 1) vi  
( *C. Super* )
- 2) saveconf .
- 3) applyconf .

```
root@192.168.0.117:~# configmenu
or
root@192.168.0.117:~# cd /tmp/cnf
root@192.168.0.117:/tmp/cnf# vi redirect.cnf
root@192.168.0.117:/tmp/cnf# saveconf
root@192.168.0.117:/tmp/cnf# applyconf
```

## 8.6. script

Shell script /usr2/rc.user Super 가 .  
script rc.user

```
#!/bin/bash
#
# rc.user : Sample script file for running user programs at boot time
#
```

```
#PATH=/bin:/usr/bin:/sbin:/usr/sbin
# Add shell command to execute from here

echo `This is the welcome message defined by users`exit 0
```

## 8.7. File

ftp

/usr2

```
root@192.168.0.117:~# cd /usr2
root@192.168.0.117:/usr2# ftp 192.168.2.3
Connected to 192.168.2.3.
220 lxtoo.senalab.co.kr FTP server (Version wu-2.6.1-16) ready.
Name (192.168.2.3:root): sena
331 Password required for sena.
Password:
230 User sena logged in.
Remotesystem type is UNIX.
Using binary mode to transfer files.
ftp> get test.tgz
local: test.tgz remote: test.tgz
200 PORT command successful.
150 Opening BINARY mode data connection for test.tgz (350 bytes).
226 Transfer complete.
350 bytes received in 0.04 secs (9.6 kB/s)
ftp> bye
```

scp

Encrypt

PC Super (192.168.0.120)  
PC

```
[root@localhost work]# scp root@192.168.0.120:/usr2/rc.user /work
The authenticity of host '192.168.0.120 (192.168.0.120)' can't be established.
RSA key fingerprint is c1:70:ab:52:48:ab:e5:dc:47:9c:94:ed:99:6f:94:4f.
Are you sure you want to continue connecting (yes/no)? yes
Warning: Permanently added '192.168.0.120' (RSA) to the list of known hosts.
root@192.168.0.120's password:
rc.user          100% |*****| 173      00:00
[root@localhost work]#
```

## 8.8.

### 8.8.1. telnet disable

Super , (SSH TCP 22 telnet TCP 23)  
/Telnet/SSH Super  
가  
.  
script rc.user , (telnet SSH)  
가 . 2가 가  
.

#### Example1. 'inetd.conf'

1 /etc/inetd.conf (telnet comment out )  
2 inetd.conf /usr2/inetd.conf  
3 /usr2/rc.user script

```
#!/bin/bash
#
# rc.user : Sample script file for running user programs at boot time
#
#PATH=/bin:/usr/bin:/sbin:/usr/sbin
# Add shell command to execute from here
# Add shell command to execute from here
cp -a /usr2/inetd.conf /etc/inetd.conf
ps -ef
while killall inetd 2>/dev/null;
do sleep 1;
ps -ef
done
/usr/sbin/inetd
ps -ef
exit 0
```

telnet 가 가

#### 2. iptables rule

1 /usr2/rc.user script

```
#!/bin/bash
#
```

```

# rc.user : Sample script file for running user programs at boot time
#
#PATH=/bin:/usr/bin:/sbin:/usr/sbin
# Add shell command to execute from here
# if user wants to disable telnet service from all host
iptables -A INPUT -p tcp -s --dport 23 -j DROP
# if user wants to enable telnet service only from specific hosts(192.168.0.0 ~
192.168.0.255)
#iptables -A INPUT -p tcp -s ! 192.168.0.1/255.255.255.0 --dport 23 -j DROP
exit 0

```

telnet disable 가  
 가 Factory Reset , Super , /usr2/rc.user  
 script /usr2/rc.user.old# rc.user

## 9. 가

### 9.1.

Super

Super

. Super

.  
-  
-  
-

### 9.2.

crontab

. crontab

가

1 /usr2

crontab

.

crontab

/tmp

current-date

2

```
SHELL=/bin/bash
# Sample crontab job
# Run every two minutes
* * * * * echo `date` > /tmp/current_date
```

2

crontab

.

```
root@SS800_Device:/usr2# crontab samplecrontab_file
```

3

cron

rc.user

```
#!/bin/bash
#
# rc.user : Sample script file for running user programs at boot time
#
#PATH=/bin:/usr/bin:/sbin:/usr/sbin
# Add shell command to execute from here
crontab /usr/samplecrontab_file
exit 0
```

SS -e ( crontab )  
 . vi crontab  
 .  
 crontab crontab . (man 5  
 crontab).

### 9.3.

Super  
 가  
 3.9 (Web Server Configuration)  
 가 (Customer Page) , 가  
 가  
 index.html CGI  
 Super /usr2  
 index.html index.html  
 CGI , 가 CGI  
 . CGI  
 (cross development environment) SDK(Software Development Kit)가  
 . Super SDK  
 (Sena Technical Support)

### 9.4.

Super  
 SDK(Software Development Kit)가 . Super SDK PC CF  
 (Super SDK  
 ).  
 Super SDK , Super CLI  
 Super 가 (Super customization  
 guide)  
 , PC

Super

( ) crontab

4.2.8



# 1.

## A 1.1 Ethernet Pin outs

Super

AT&T 258

Ethernet

A-1

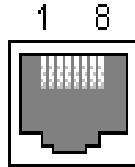

A-1. RJ45

A-1. Ethernet RJ45

Pin	Function	
1	Tx+	
2	Tx-	
3	Rx+	
4	NC	
5	NC	
6	Rx-	
7	NC	
8	NC	

## A 1.2 SS100

## Pin out

SS100

DB9

DB9

A-2

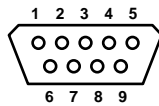

A-2 DB-9

(SS100 )

A-2 DB-9

(SS100 )

Pin	RS232	RS422	RS485
1	-	Tx-	Data-
2	Rx	-	-
3	Tx	Rx-	-
4	DTR	Rx+	-
5	GND	-	-
6	DSR	-	-
7	RTS	-	-
8	CTS	-	-
9	-	Tx+	Data+

## A 1.3 SS110/400/800

## Pin out

SS110/400/800

RJ45

RJ45

A-3

A-3

RJ45

Pin	RS232 (console and serial ports)	RS485 (serial ports only)	RS422 (serial ports only)
1	CTS	Data+	Tx+
2	DSR	-	-
3	RxD	Data-	Tx-
4	GND	-	-
5	DCD	-	-
6	TxD	-	Rx-
7	DTR	-	-
8	RTS	-	Rx+

## A 1.4 Ethernet

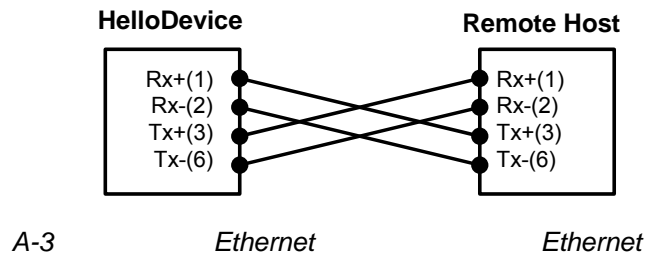

A-3

Ethernet

Ethernet

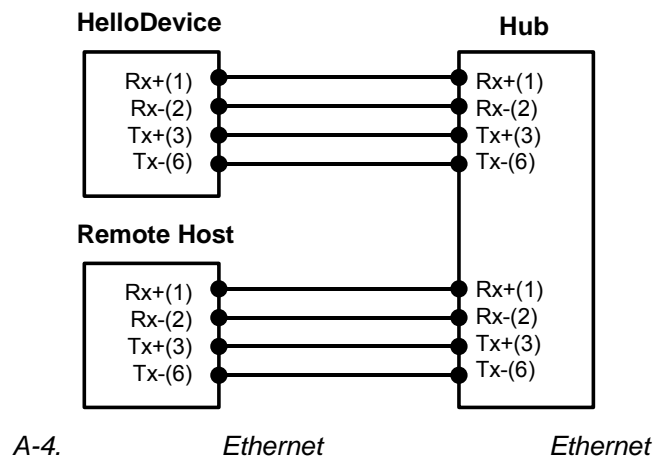

A-4.

Ethernet

Ethernet

## A 1.5

### A 1.5.1 RS232

(SS100 )

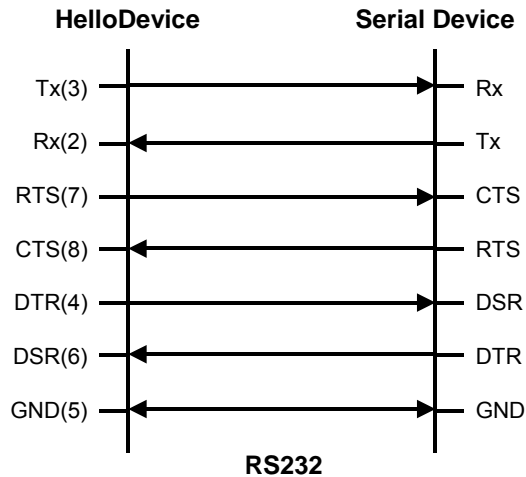

A-5 RS232

(SS100 )

### A 1.5.2 SS110/400/800 RS232

#### RJ45-DB9 female adapter

Using RJ45 to DB9(Female) **Cross-over** Cable

Description (RJ45)	Internal Cable Color	RJ45 Pin No.	DB9 Pin No.	Description (DB9)
CTS	Blue	1	7	RTS
DSR	Orange	2	4	DTR
RXD	Black	3	3	TXD
GND	Red	4	5	GND
DCD	Green	5	1	DCD
TXD	Yellow	6	2	RXD
DTR	Brown	7	6	DSR
RTS	White	8	8	CTS

#### RJ45-DB25 female adapter

Using RJ45 to DB25(Female) **Cross-over** Cable

Description (RJ45)	Internal Cable Color	RJ45 Pin No.	DB25 Pin No.	Description (DB25)
CTS	Blue	1	4	RTS
DSR	Orange	2	20	DTR
RXD	Black	3	2	TXD
GND	Red	4	7	GND
DCD	Green	5	8	DCD
TXD	Yellow	6	3	RXD
DTR	Brown	7	6	DSR
RTS	White	8	5	CTS

**RJ45-DB25 male adapter**

Using RJ45 to DB25(Male) **Cross-over** Cable

Description (RJ45)	Internal Cable Color	RJ45 Pin No.	DB25 Pin No.	Description (DB25)
CTS	Blue	1	4	RTS
DSR	Orange	2	20	DTR
RXD	Black	3	2	TXD
GND	Red	4	7	GND
DCD	Green	5	8	DCD
TXD	Yellow	6	3	RXD
DTR	Brown	7	6	DSR
RTS	White	8	5	CTS

**RJ45-DB25 male adapter**

Using RJ45 to DB25(Male) **Straight** Cable

Description (RJ45)	Internal Cable Color	RJ45 Pin No.	DB25 Pin No.	Description (DB25)
CTS	Blue	1	5	CTS
DSR	Orange	2	6	DSR
RXD	Black	3	3	RXD
GND	Red	4	7	GND
DCD	Green	5	8	DCD
TXD	Yellow	6	2	TXD
DTR	Brown	7	20	DTR
RTS	White	8	4	RTS

**A 1.5.3 RS422/485**

(SS100 )

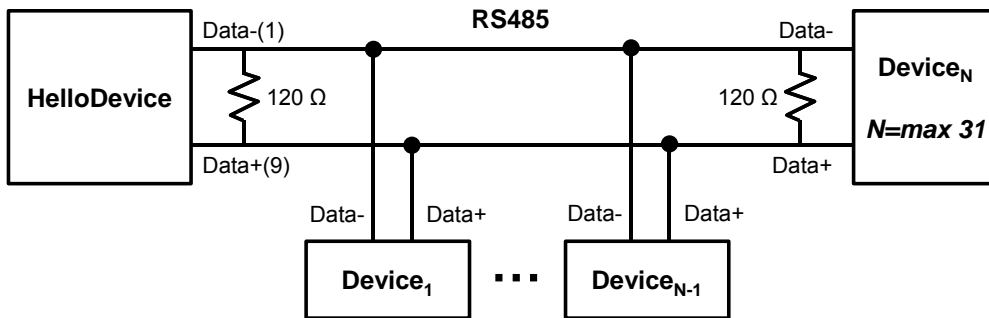

A-6 RS485

(SS100 )

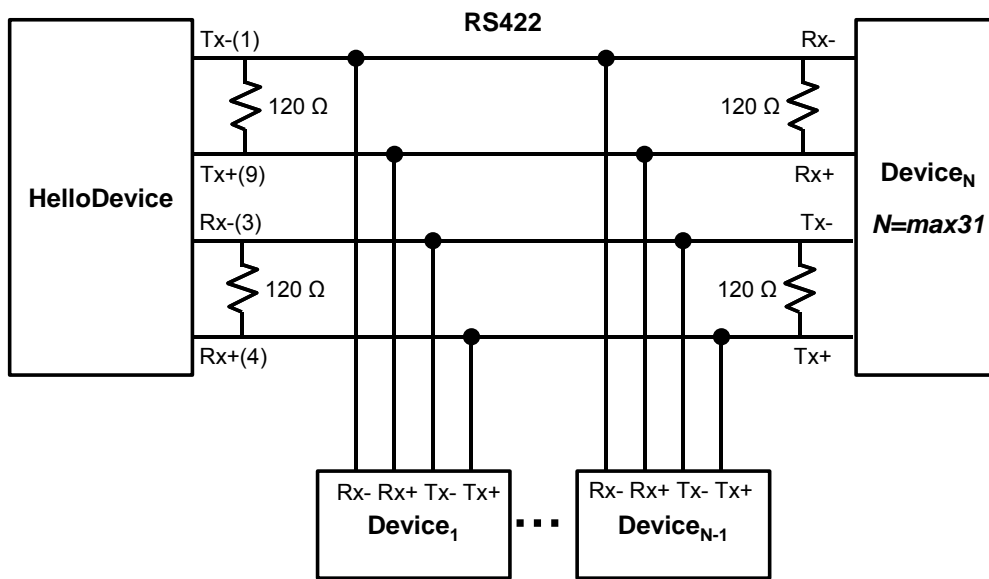

A-7 RS422 (SS100 )

A 1.5.4 SS110/400/800 RS422/485

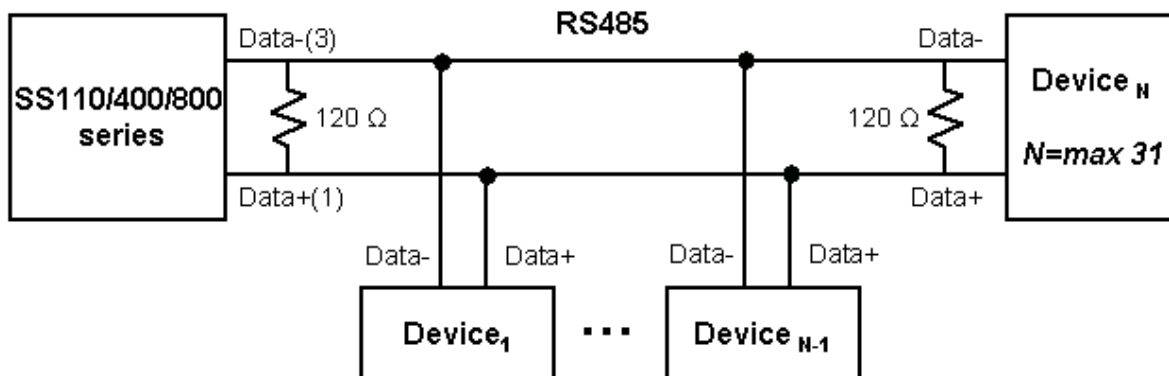

A-8 SS110/400/800 RS485

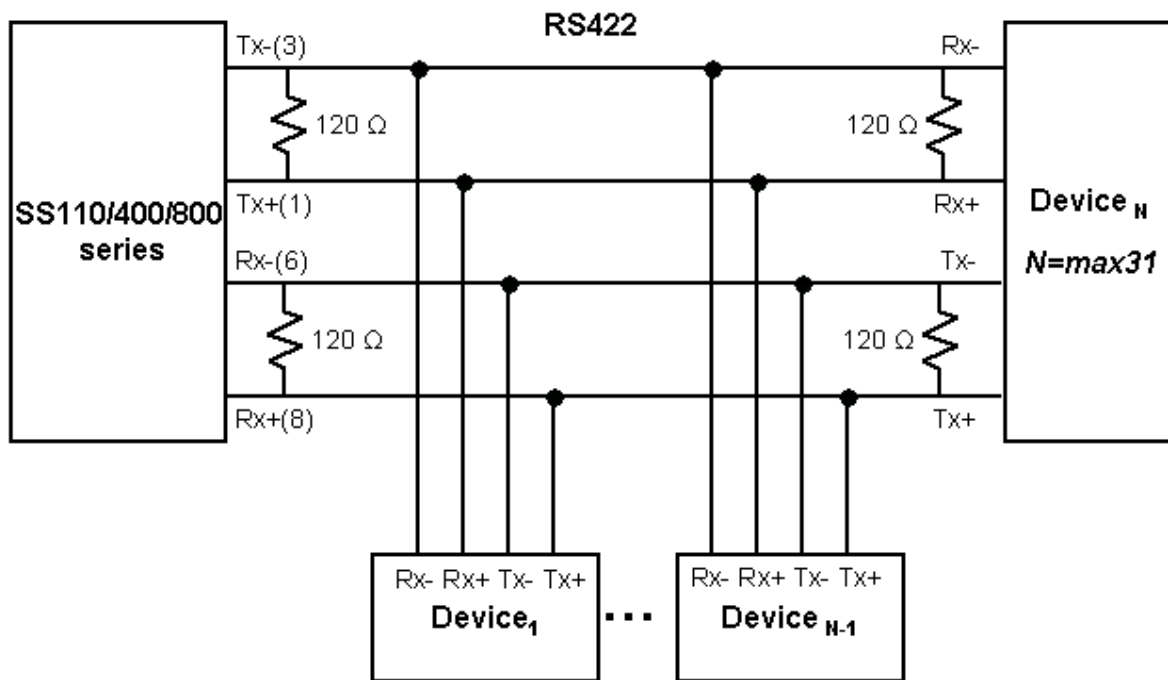

A-9 SS110/400/800 RS422

RS422

## 2. Super 가 PC

Super

PC

A-4

Manufacturer	Model/Name	SS probed Model name	Specification
3COM	3CXE589ET-AP	3Com Megahertz 589E TP/BNC LAN PC Card	10 Mbps LAN card
Linksys	Linksys EtherFast 10/100 Integrated PC Card (PCM100)	Linksys EtherFast 10/100 Integrated PC Card (PCM100) Ver 1.0	10/100 Mbps LAN card
Corega	FetherII PCC-TXD	corega K.K. corega FEtherII PCC-TXD	10/100 Mbps LAN card
Netgear	16bit PCMCIA Notebook Adapter FA411	NETGEAR FA411 Fast Ethernet	10/100 Mbps LAN card

A-5

Manufacturer	Model/Name	SS probed Model name	Specification
Cisco Systems	AIR-PCM340/Aironet 340	Cisco Systems 340 Wireless LAN Adapter	11 Mbps Wireless LAN Adapter
Lucent Technologies	PC24E-H-FC/Orinoco Silver	Lucent Technologies WaveLAN/IEEE Version 01.01	11 Mbps Wireless LAN Adapter
Lucent Technologies	PC24E-H-FC/Orinoco Gold	Lucent Technologies WaveLAN/IEEE Version 01.01	11 Mbps Wireless LAN Adapter
Agere Systems (Lucent Technologies)	Orinoco Classic Gold (PC24E-H-FC/Orinoco Gold)	Lucent Technologies WaveLAN/IEEE Version 01.01	11 Mbps Wireless LAN Adapter
Buffalo	AirStation (WLI-PCM-L11GP)	MELCO WLI-PCM-L11 Version 01.01	11 Mbps Wireless LAN Adapter

A-6 ATA/IDE Fixed

Manufacturer	Model/Name	SS probed Model name	Specification
Advantech	CompactFlash	CF 48M	48 MB Storage card
SanDisk	SDP series	SunDisk SDP 5/3 0.6	64 MB Storage card
SanDisk	SDP series	SanDisk SDP 5/3 0.6	256 MB Storage card
Kingston	CompactFlash Storage Card	TOSHIBA THNCF064MAA	64 MB Storage card
Viking	CompactFlash	TOSHIBA THNCF064MBA	64 MB Storage card

## A-7

Manufacturer	Model/Name	SS probed Model name	Specification
Billionton Systems Inc.	FM56C series	PCMCIA CARD 56KFaxModem FM56C-NFS 5.41	Ambient (Intel) V.90 FAX/MODEM PC Card
Viking	PC Card Modem 56K	Viking V.90 K56flex 021 A	MODEM PC Card
KINGMAX	KIT PCMCIA 56K Fax/Modem Card	CIRRUS LOGIC 56K MODEM CL-MD56XX 5.41	V.90 FAX/MODEM PC Card
TDK	TDK DH6400	TDK DH6400 1.0	64Kbps
NTT DoCoMo	Mobile Card Triplex N	NTT DoCoMo Mobile Card Triplex N	64Kbps



## 3. Super

### A 3.1 System.cnf

```
#
# system.cnf
#
# system configuration which exist only one place on this file.
#

# kind of IP configuration mode
# 1 - static ip , 2 - dhcp , 3 - pppoe
ipmode = 1

# system ip address
ipaddr = 192.168.161.5

# system subnet mask
subnet = 255.255.0.0

# system gateway
gateway = 192.168.1.1

# dns configuration
# 'p_dns' is a primary dns ip address and 's_dns' is a secondary dns ip address
# if you want to set dns authmatically in case of dhcp or pppoe,
# you can set 'bmanual_dns' to 0.
p_dns = 168.126.63.1
s_dns = 168.126.63.2

# pppoe configuration
# 'ppp_usr' is pppoe account name and 'ppp_pwd" is a password for that account
ppp_usr = whoever
ppp_pwd = pppoepwd

# Email logging configuration
# if you want to send log via E-mail, set 'emaillog' to 1
# 'emaillog_num' trigger sending email.
# The number of logs are greater than 'emaillog_num", then send it.
emaillog = 0
emaillog_num = 5

# SMTP configuration
# 'smtpsvr' is a SMTP server .
# 'sysmailaddr' is a sender address.
# 'rcvmailaddr' is a receiver address.
# 'smtp_mode' means a SMTP server authentication mode.
# 1 - smtp w/o authentication , 2 - pop before smtp , 3 - smtp w/
authentication
# If 'smtp_mode" is 2 or 3, you need SMTP account information.
# 'smtp_user' is a SMTP account name and 'smtp_pwd" is a password.
bsmtp = 0
smtpsvr = smtp.yourcompany.com
sysmailaddr = SS800@yourcompany.com
rcvmailaddr = admin@yourcompany.com
smtp_mode = 1
smtp_user = admin
smtp_pwd = admin

# 'device_name' mean a unit name assigned. A unit name will be a identifier
among PS products.
device_name = SS800 Device

# IP filtering configuration
```

```

# By setting 'btelnet' to 1, you can use remote console.
# Similarly by setting 'bweb' to 1, you can use remote console.
# 0 means that protect any access.
# 'enable_ip', 'enable_netmask' pair is a source rule specification for remote
console filtering.
# 'enable_webip', 'enable_webnetmask' pair is for web filtering.
btelnet = 1
bweb = 1
enable_ip = 0.0.0.0
enable_netmask = 0.0.0.0
enable_webip = 0.0.0.0
enable_webnetmask = 0.0.0.0

# dynamic DNS(DDNS) configuration
# dynamic dns can be enabled by setting 'bdyndns' to 1. 0 for disable.
# 'dyn_dn' is a domain name for your DDNS.
# 'dyn_user' is a account name for DDNS and 'dyn_pwd' is a password for it.
bdyndns = 0
dyn_dn = ss800.dyndns.biz
dyn_user = ss800-user
dyn_pwd = ss800-pwd

# NTP configuration
# 'ntp_enable' set to 1 for using NTP or set to 0.
# 'ntp_serverip' is the IP address of NTP server and 'ntp_offset' is a your
offset from UTC.
# If you don't know any NTP server IP, then set 'ntp_auto_conf' to 1.
ntp_enable = 0
ntp_auto_conf = 1
ntp_offset = 0.0
ntp_serverip = 192.168.200.100

# Log configuration
# system logging is enabled by 'log_enable' to 1.
# 'logbuf_size' is a variable for representing log buffer size by KB.
# 'log_stoloc' is a location to save log.
# 1 = memory 2 = CF card 3 = NFS 4 = SYSLOGD
# If you choose log location to SYSLOGD, 'logbuf_size' you've set will loose his
role - limiting log file size.
log_enable = 1
logbuf_size = 4
log_stoloc = 1

# syslog configuration
# You can run or kill syslogd by setting 'bsyslog_service' to 1 or 0.
# 'syslog_ip' is a IP addresss of a remote syslog server.
# 'syslog_2ndip' is a IP address of a secondary syslogd server which will get
the same logs.
# 'syslog_facility' specify what type of program is logging. 0 ~ 7 for LOCAL0 to
LOCAL7
bsyslog_service = 0
syslog_ip = 192.168.200.100
syslog_facility = 0

# NFS configuration
# You can mount or unmount NFS by setting 'bnfs_service' to 1 or 0.
# 'nfs_ip' is a NFS server IP addresss and 'nfs_path' is a mount path.
bnfs_service = 0
nfs_ip = 192.168.200.100
nfs_path = /

# WEB configuration
# If you want to support HTTP, then set 'bweb_http' to 1. If not, set tot 0.
# 'bweb_https' is for HTTPS.
# 'web_refresh_rate' is for refresh the changing page when you see the system
status page.
bweb_http = 1

```

```

bweb_https = 1
web_refresh_rate = 10

# TCP configuration
# 'keepalive_time' is a time before keep alive takes place.
# 'keepalive_probes' is the number of allowed keep alive probes.
# 'keepalive_intvl' is a time interval between keep alive probes.
keepalive_time = 15
keepalive_probes = 3
keepalive_intvl = 5

# Ethernet configuration
# 'ethernet_mode' is a ethernet mode.
# 0 = Auto Negotiation, 1 = 100BaseT Half Duplex, 2 = 100BaseT Full Duplex,
# 3 = 10BaseT Half Duplex, 4 = 10BaseT Full Duplex
ethernet_mode = 0

# PCMCIA configuration
# 'pcmcia_card_type' shows a pcmcia card type.
# 0 for empty , -1 for unsupported card, 1 for CF card, 2 for Network card,
# 3 for Wireless Network card, 4 for Serial Modem card
pcmcia_card_type = 0

# PCMCIA ipconfiguration
# same with system ip configuration
pcmcia_ipmode = 2
pcmcia_ip = 192.168.1.254
pcmcia_subnet = 255.255.255.0
pcmcia_gateway = 192.168.1.1
pcmcia_ppp_usr = whoever
pcmcia_ppp_pwd = pppoepwd
pcmcia_bmanual_dns = 0

# In case of serial modem card, 'pcmcia_modem_initstr' means a modem init string.
pcmcia_modem_initstr = q1e0s0=2

# Wireless network card configuration
# To enable or disable Wired Equivalent Privacy(WEP), set 'pcmcia_wep_enb' to 1
or 0.
# 'pcmcia_wep_mode' is a WEP mode. 1 for encrypted, 2 for shared
# 'pcmcia_wep_length' is a length for WEP. 1 for 40 bits, 2 for 128 bits
# 'pcmcia_wep_key_str' is a key string for WEP.
pcmcia_wep_enb = 0
pcmcia_wep_mode = 1
pcmcia_wep_length = 1

# 'pcmcia_cf_conf_max' is a maximum size to use in case of CF card.
pcmcia_cf_conf_max = 0

```

## A 3.2 Redirect.cnf

```

#
# redirect.cnf
#
# Port configuration is placed on this file.
# Basically keys followed by 'port' key are data for those port.
# Port number is zero base index and the maximum value for port is used as all
port configuration
# Data followed by all port are default values and will NOT be applied.

# 'port' key notify the port data follow.
# If you want to activate the port, set 'benable' to 1. If not, set to 0.
# If you set 'bmanset' to 1, you don't want to change the port data by changing

```

```

all port configuration.
# If you want to change the port data by changing all port configuration, set to
0.
port = 0
benable = 0
bmanset = 0
port = 1
benable = 0
bmanset = 0
port = 2
benable = 0
bmanset = 0
port = 3
benable = 0
bmanset = 0
port = 4
benable = 0
bmanset = 0
port = 5
benable = 0
bmanset = 0
benable = 0
port = 6
bmanset = 0
benable = 0
port = 7
bmanset = 0
benable = 0

# As refered, maximum port (in case 8 port machine ,8) represents the
# defaults values for all port configuration.
port = 8
benable = 0
bmanset = 0

# Serial parameter configuration
# 'uarttype' is for UART type. But PS only support RS232.
# So set 'uarttype' to 0 and DO NOT CHANGE.
# 'baudrate' is for baudrate. From 1200 to 230400 is available.
# 'stopbits' is for stop bits. 1 for 1 bit, 2 for 2 bits
# 'databits' is for data bits. 7 for 7 bits, 8 for 8 bits.
# 'parity' is for parity. 0 for none, 1 for even , 2 for odd parity.
# 'flowcontrol' is for flow control. 0 for none, 1 for XON/XOFF,
# 2 for hardware flow control
# 'dtropt' is for DTR pin option.
# 1 = Always HIGH, 2 = Always LOW, 3 = High when open
# 'dsropt' is for DSR pin option.
# 0 = None, 1 = Allow TCP connection only by HIGH 2 = open/close TCP connection
# 'interchartimeout' is for inter-character timeout. It works ONLY FOR RAWTCP
# mode.
uarttype = 0
baudrate = 9600
stopbits = 1
databits = 8
parity = 0
flowcontrol = 0
dtropt = 0
dsropt = 0
interchartimeout = 100

# Host mode configuration
# 'hostmode' means a host mode.
# 0 = TCP mode, 1 = UDP mode, 2 = Mode emulation
hostmode = 0
# In TCP mode, 'localport' is a listening port.
localport = 0
# 'max_connection' is a maximum allowed number of remote host

```

```

max_connection = 32
# 'remotehost' is a remote host list
#           (Primary IP address:port Secondary IP address:port)
remotehost = 192.168.0.135:7000 192.168.0.135:7001
# 'cyclicttime ' is a cyclic connection time in seconds
cyclicttime = 10
# 'inactivitytimeout' is a inactivity timeout in seconds.
inactivitytimeout = 100

# Cryptography Options
# 'encryptionmode' is encryption mode
# 0 = None, 1 = SSLv2, 2 = SSLv3, 3 = SSLV3 rollback v2, 4 = TLSv1
# 'encryptionkey' is encryption key file name
# 'key_password' is password for encryption key file
# 'cipher_suite' represents a combination of cipher suite.
# 'verify_client' is Verify client(server mode only) option
# 0 = No, 1 = Yes
# 'verify_chain_depth' is a number of chain depth to be searched
# 'verify_cn' is Compare the certificate CN and hostname option
# 0 = No, 1 = Yes
encryptionmode = 2
encryptionkey =
key_password = testing
cipher_suite = 524287
verify_client = 1
verify_chain_depth = 3
verify_cn = 1

# In UDP mode,
# 'accept_unlisted' is Accept UDP datagram from unlisted remote host option
# 0 = No, 1 = Yes
# 'send_to_unlisted' Send to recent unlisted remote host option
# 0 = No, 1 = Yes
accept_unlisted = 1
send_to_unlisted = 1

# IP filtering configuration
# 'allow_ip', 'allow_netmask' pair is a source rule specification for serial
port access filtering.
allow_ip = 0.0.0.0
allow_netmask = 0.0.0.0

# 'porttitle' is a port title.
porttitle = Port Title

# Mode configuration option
# 'modem_mode' is modem mode option
# 0 =Disable, 1 =Enable
# 'modem_initstr' is a modem initialization string
# 'modem_dcd_option' is modem DCD pin option
# 0 = None, 1 = Allow TCP connection only by HIGH
modem_mode = 0
modem_initstr =
modem_dcd_option = 0

# Event notification configuration
# Enable of disable Event notification by setting 'event_enable' to 1 or 0.
# 'notification_interval' is interval of event notification.
# 'bmail_handle' is a Enable/Disable E-mail notification option
# 0 = Disable, 1 = Enable
# 'mail_title' is a title of email notification.
# 'mail_address' is a mail recipient's address
# 'bsnmp_handle' is a Enable/Disable SNMP notification option
# 0 = Disable, 1 = Enable
# 'snmp_title' is a title of SNMP trap notification.
# 'snmp_trap_receiver_ip' is a IP address of SNMP Trap receiver

```

```

# 'snmp_trap_receiver_community' is community of SNMP Trap
# 'snmp_trap_receiver_version' is SNMP trap version
# 0 = v1, 1 = v2c
event_enable = 1
notification_interval = 0
bmail_handle = 1
mail_title = jungoj@sena.com
mail_address = jung@sss.com
bsnmp_handle = 1
snmp_title = khfgj
snmp_trap_receiver_ip = 192.168.0.8
snmp_trap_receiver_community = public
snmp_trap_receiver_version = 0

# Event Keyword option
# 'keyword_index' is a index of keyword event
# 'keyword_str' is a event keyword
# 'snmp_enable' is a SNMP notification option for keyword
# 0 = Disable, 1 = Enable
# 'mail_enable' is a email notification option for keyword
# 0 = Disable, 1 = Enable
# 'command_enable' is a port command option for keyword
# 0 = Disable, 1 = Enable
# 'port_command' is a port command string for keyword
keyword_index = 0
keyword_str = test
snmp_enable = 1
mail_enable = 1
command_enable = 1
port_command = fghfgh

# Port buffering configuration
# Enable of disable port buffering by setting 'pb_enable' to 1 or 0.
# 'pb_size' is a maximum port buffering size. Maximum value are different by
location.
# 'pb_loc' is a location to store port buffer data.
# 1 = memory 2 = CF card 3 = NFS 4 = SYSLOGD
pb_enable = 0
pb_size = 4
pb_loc = 1

# filter application option
# 'filter_app' is the name and location of filter application
# 'filter_arg' is a option string for filter application
filter_app = /bin/ss.filter
filter_arg =

```

## 4.

3가 (Well Known Port), (registered port), (Dynamic) (private port)  
 0~1023 , 1024 49151  
 49152 65535

IANA가 ,  
 가 가 D-1  
 IANA

<http://www.iana.org/assignments/port-numbers>

A-8

Port number	Protocol	TCP/UDP
21	FTP (File Transfer Protocol)	TCP
22	SSH (Secure SHell)	TCP
23	Telnet	TCP
25	SMTP (Simple Mail Transfer Protocol)	TCP
37	Time	TCP, UDP
39	RLP (Resource Location Protocol)	UDP
49	TACACS, TACACS+	UDP
53	DNS	UDP
67	BOOTP server	UDP
68	BOOTP client	UDP
69	TFTP	UDP
70	Gopher	TCP
79	Finger	TCP
80	HTTP	TCP
110	POP3	TCP
119	NNTP (Network News Transfer Protocol)	TCP
161/162	SNMP	UDP
443	HTTPS	TCP

## 5. Guide to the Bootloader

### A 5.1

Bootloader , BOOTP/TFTP Super  
 . Super 3  
가 <ESC> , bootloader .  
 ,  
firmware .

### A 5.2

Bootloader 가 , .

```
Bootloader 1.1.0 (May 23 2003 - 22:48:25)
CPU      : XPC855xxZPnnD4 (50 MHz)
DRAM    : 64 MB
FLASH   : 8 MB
PC CARD : No card
EEPROM  : A Type exist
Ethernet : AUTO-NEGOTIATION
Autoboot Start: 0
-----
Welcome to Boot Loader Configuration page
-----
Select menu
1. RTC configuration [ Feb 14 2003 - 11:00:26 ]
2. Hardware test
3. Firmware upgrade [S/W Version : v1.0.0]
4. Exit and boot from flash
5. Exit and reboot
<ESC> Back, <ENTER> Refresh
----->
```

*A-10 Boot loader*



## A 5.3 RTC

RTC

Super

```

-----
RTC configuration
-----
Select menu
1. Date(mm/dd/yy) : 02/14/03
2. Time(hh:mm:ss) : 13:27:12
<ESC> Back, <ENTER> Refresh
-----> 1
Enter Current Date (mm/dd/yy) : 02/15/03
press the ENTER key to continue

-----
RTC configuration
-----
Select menu
1. Date(mm/dd/yy) : 02/15/03
2. Time(hh:mm:ss) : 13:27:20
<ESC> Back, <ENTER> Refresh
-----> 2
Enter Current Time (hh:mm:ss) : 13:25:00
press the ENTER key to continue

-----
RTC configuration
-----
Select menu
1. Date(mm/dd/yy) : 02/15/03
2. Time(hh:mm:ss) : 13:25:01
<ESC> Back, <ENTER> Refresh
----->

```

A-11 Boot loader

RTC

## A 5.4

```

3가
- 1
- ( )
- ( )

가 1 , 가
, ( IP ) ping UART 가
가 ( ) , 가 <ctrl-c>
가 , ( IP

```

```

) ping   UART   가
가   (   )   ,   가 <ctrl-c>
      가   ,   (   IP   )

ping   UART   가

:

Ethernet   UART   ,   Super   Ethernet
Ethernet   Super
      ,   IP   가

IP   192.168.0.128   [Firmware Upgrade]

```

```

-----
Hardware Test
-----
Select menu
0. Test Mode - One time
1. Auto test
2. DRAM test
3. FLASH test
4. LED test
5. EEPROM test
6. UART test
7. PC card test
8. Ethernet test
<ESC> Back, <ENTER> Refresh
-----> 0

-----
Hardware Test
-----
Select menu
0. Test Mode - Looping(without External test in Auto test)
1. Auto test
2. DRAM test
3. FLASH test
4. LED test
5. EEPROM test
6. UART test
7. PC card test
8. Ethernet test
<ESC> Back, <ENTER> Refresh
----->0

-----
Hardware Test
-----
Select menu
0. Test Mode - Looping(with External test in Auto test)
1. Auto test
2. DRAM test
3. FLASH test
4. LED test
5. EEPROM test
6. UART test
7. PC card test
8. Ethernet test

```

```
<ESC> Back, <ENTER> Refresh
----->0
```

```
-----
Hardware Test
-----
```

```
Select menu
0. Test Mode - One time
1. Auto test
2. DRAM test
3. FLASH test
4. LED test
5. EEPROM test
6. UART test
7. PC card test
8. Ethernet test
<ESC> Back, <ENTER> Refresh
----->
```

### A-12 Boot loader

가 [Auto test]

가

```
-----
Hardware Test
-----
```

```
Select menu
0. Test Mode - One time
1. Auto test
2. DRAM test
3. FLASH test
4. LED test
5. EEPROM test
6. UART test
7. PC card test
8. Ethernet test
<ESC> Back, <ENTER> Refresh
----->1
```

```
***** Hardware auto-detect and auto-test *****
```

```
[DRAM]
```

```
DRAM Test in progress -----[ 65536KB]
```

```
DRAM Test -----[SUCCESS]
```

```
[FLASH]
```

```
Flash Test Status-----[ 100 %]
```

```
Flash Test -----[SUCCESS]
```

```
[FAN]
```

```
Fan Status -----[7020 RPM]
```

```
[LED]
```

```
SERIAL READY LED ON/OFF-----3 time(s)
```

```
[EEPROM]
```

```
EEPROM : A Type exist
```

```
EEPROM Test ----- [SUCCESS]
```

```
[UART]
```

```
<--Internal loop test-->
```

```
Port # 1 test in progressing(Read/Write)-----[SUCCESS]
```

```
Port # 2 test in progressing(Read/Write)-----[SUCCESS]
```

```

.
.
.
Port # 7 test in progresssing(Read/Write)-----[SUCCESS]
Port # 8 test in progresssing(Read/Write)-----[SUCCESS]

<--External loop test-->
Port # 1 test in progresssing(Read/Write)-----[SUCCESS]
          (RTS/CTS)-----[SUCCESS]
          (DTR/DSR)-----[SUCCESS]
Port # 2 test in progresssing(Read/Write)-----[SUCCESS]
          (RTS/CTS)-----[SUCCESS]
          (DTR/DSR)-----[SUCCESS]
.
.
.
Port # 7 test in progresssing(Read/Write)-----[SUCCESS]
          (RTS/CTS)-----[SUCCESS]
          (DTR/DSR)-----[SUCCESS]
Port # 8 test in progresssing(Read/Write)-----[SUCCESS]
          (RTS/CTS)-----[SUCCESS]
          (DTR/DSR)-----[SUCCESS]

[PCMCIA]
5V CARD
5.0V card found: Lucent Technologies WaveLAN/IEEE Version 01.01
                Network Adapter Card

[Ethernet]
Ethernet chip test-----[SUCCESS]
PING 192.168.0.135 from 192.168.161.5 : 64 bytes of ethernet packet.
64 bytes from 192.168.0.135 : seq=0 ttl=255 timestamp=11172879 (ms)
64 bytes from 192.168.0.135 : seq=1 ttl=255 timestamp=11173874 (ms)
64 bytes from 192.168.0.135 : seq=2 ttl=255 timestamp=11174875 (ms)
64 bytes from 192.168.0.135 : seq=3 ttl=255 timestamp=11175876 (ms)

        ***** Hardware auto-detect and auto-test SUMMARY *****
1. DRAM Test -----[SUCCESS]
2. FLASH Test -----[SUCCESS]
3. FAN Test -----[SUCCESS]
4. EEPROM Test-----[SUCCESS]
5. UART Test Summary
   Port NO | exist status | exist status | exist status | exist status
-----
--
Port 01-04| YES SUCCESS | YES SUCCESS | YES SUCCESS | YES SUCCESS
Port 05-08| YES SUCCESS | YES SUCCESS | YES SUCCESS | YES SUCCESS

6.PC CARD Test Summary
5V CARD
5.0V card found: Lucent Technologies WaveLAN/IEEE Version 01.01
                Network Adapter Card
7. PING Test -----[SUCCESS]

PRESS any key to continue!!

```

A-12 Boot loader

<ESC>

-----  
Hardware Test  
-----

Select menu

0. Test Mode - One time

```

1. Auto test
2. DRAM test
3. FLASH test
4. LED test
5. EEPROM test
6. UART test
7. PC card test
8. Ethernet test
<ESC> Back, <ENTER> Refresh
-----> 1

***** Hardware auto-detect and auto-test *****
[DRAM]
DRAM Test in progress -----[ 640KB]
DRAM Test -----[SKIPPED]

[FLASH]
Flash Test Status-----[ 2 %]
FLASH Test -----[SKIPPED]

```

A-13 ESC

InUse LED 가 가 , 가  
<ctrl-c> 가 .

## A 5.5 Firmware upgrade

Firmware upgrade firmware .  
firmware , 3  
firmware . firmware upgrade firmware  
BOOTP TFTP 2 . DHCP  
BOOTP 가 TFTP , IP  
. IP 192.168.161.5 .  
Firmware upgrade , [Server's IP address] [Firmware File Name]  
firmware .

```

-----
Firmware upgrade
-----
Select menu
1. Protocol [BOOTP]
2. IP address assigned to Ethernet interface [192.168.161.5]
3. Server's IP address [192.168.0.128]
4. Firmware File Name [ss800.bin]
5. Start firmware upgrade
<ESC> Back, <ENTER> Refresh
-----> 1
Select protocol ( 1 = BOOTP, 2 = TFTP) : 2

```



```
Erase Flash Sectors 116-116 in Bank # 1  
BLOCK 3 : Copy to Flash... done  
BLOCK 4 : Erase Flash Sectors 117-117 in Bank # 1  
Firmware upgrade is finished successfully.
```

-----  
Firmware upgrade  
-----

Select menu

1. Protocol [BOOTP]
  2. IP address assigned to Ethernet interface [192.168.161.5]
  3. Server's IP address [192.168.0.128]
  4. Firmware File Name [ss800.bin]
  5. Start firmware upgrade
- <ESC> Back, <ENTER> Refresh  
----->

### *A-16 firmware upgrade*

firmware upgrade

가

,

.

## 6. Serial/IP Super

### A 6.1 Super Serial/IP

A-9 Super vs. Serial/IP

Serial Port Configuration of Super			Serial/IP Configuration		
Host mode Configuration		Cryptography Configuration	Credentials	Connection Protocol	Security
Host mode	Telnet Protocol	Encryption Method			
TCP	Disabled	None	No login required	Raw TCP connection	Disable
TCP	Enabled	None	No login required	Telnet	Disable
TCP	Disabled	“SSLv2” or “SSLv3 rollback to v2”	No login required	Raw TCP connection	Negotiate SSLv3/TSLv1
TCP	Disabled	“SSLv3” or “SSLv3 rollback to v2”	No login required	Raw TCP connection	SSLv3
TCP	Disabled	“TLSv1” or “SSLv3 rollback to v2”	No login required	Raw TCP connection	TSLv1
TCP	Enabled	“SSLv2” or “SSLv3 rollback to v2”	No login required	Telnet	Negotiate SSLv3/TSLv1
TCP	Enabled	“SSLv3” or “SSLv3 rollback to v2”	No login required	Telnet	SSLv3
TCP	Enabled	“TLSv1” or “SSLv3 rollback to v2”	No login required	Telnet	TSLv1

Super

“SSLv3 rollback to v2”

Serial/IP

“Negotiate SSLv3/TSLv1”



“SSLv3” Super 가 , Serial/IP “Negotiate SSLv3/TSLv1”  
 Super .

## A 6.2 - Telnet SSLv3 encryption

1. 1  
*Host mode = TCP,*  
*TCP listening port = 7001,*  
*Telnet protocol = Enabled*

Serial port configuration - 1 : Port #1

Enable/Disable this port

Port title

Apply all ports settings

**Host mode configuration**

Host mode : TCP

TCP listening port (1024-65535, 0 for only outgoing connections) : 7001

Telnet protocol : Enabled

Max. allowed connection (1-32) : 32

Cyclic connection to remote hosts (sec, 0 : disable) : 0

Inactivity disconnection timeout (sec, 0 : unlimited) : 0

Save to flash Save & apply Cancel

Remote host configuration

Port IP filtering

Cryptography configuration

Filter application

Serial port parameters

Modem configuration

Port logging

Port event handling

A-17

2. 1 (Cryptography configuration)

*Encryption method = SSLv3*

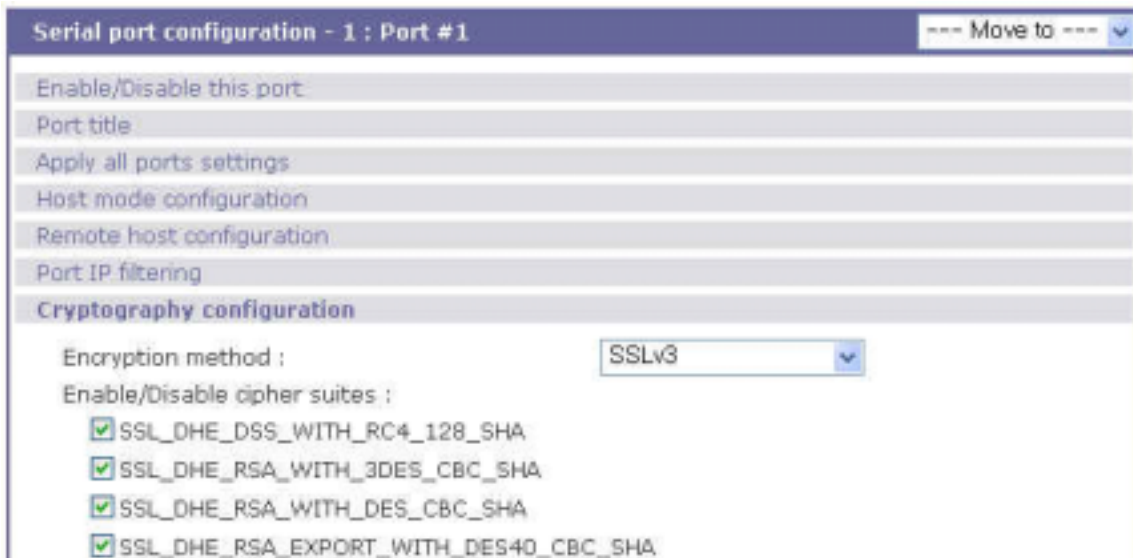

A-18 ( Cryptography configuration)

3. Open Serial/IP Control Panel , Super 1  
COM "Select Ports" .

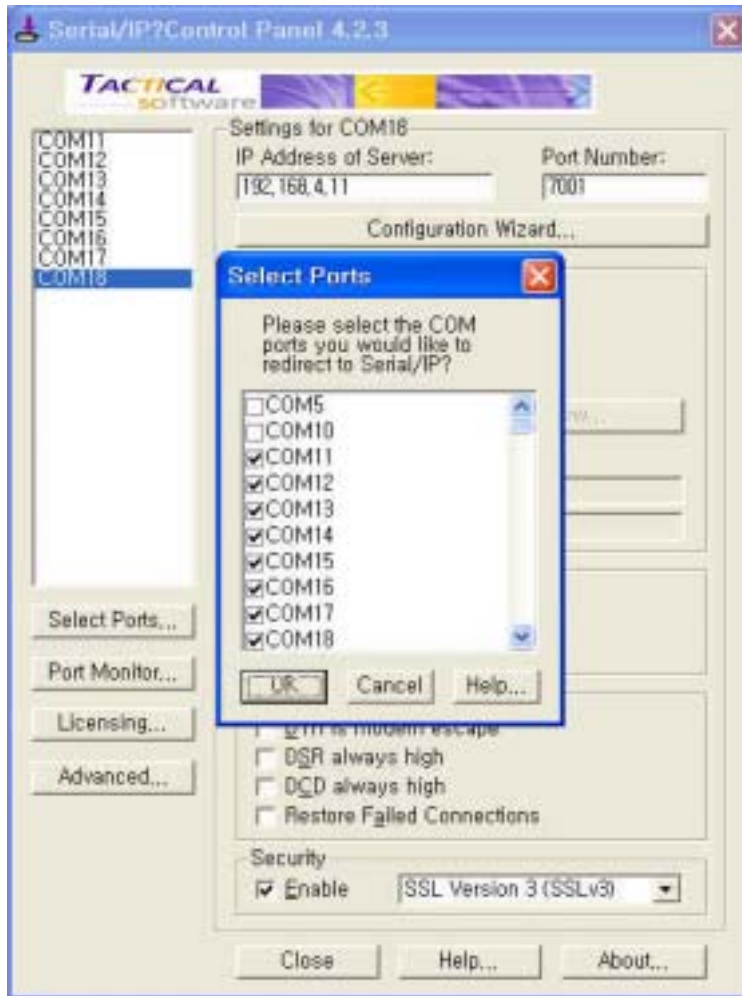

A-19 Serial/IP Control Panel

4. Enter IP (ISuper IP ) (1 )

*Credentials = No Login Required,*

*Connection Protocol = Telnet,*

*Security = SSL Version 3 (SSLv3)*

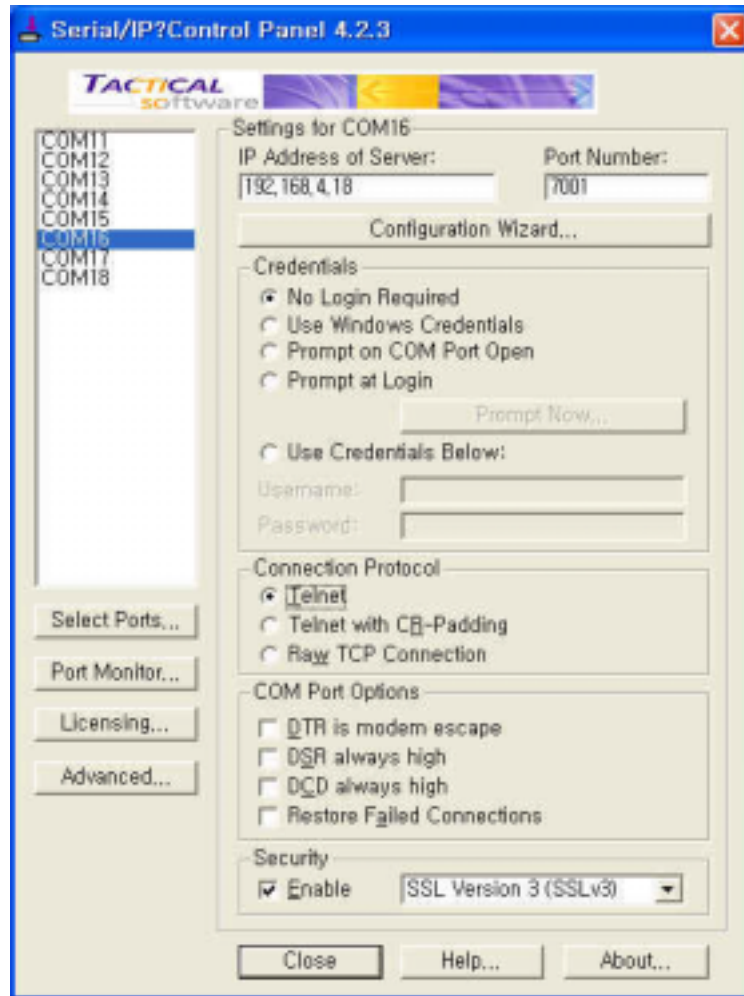

A-20 Serial/IP Control Panel

5.

PC COM  
COM  
Super

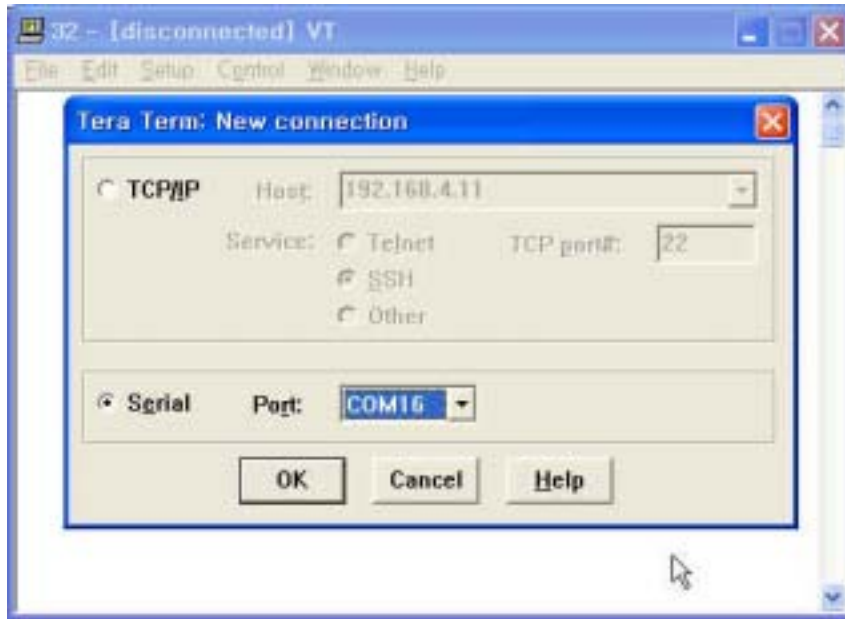

A-21 Serial/IP Super series

6. Serial/IP Serial/IP Port Monitor Trace window

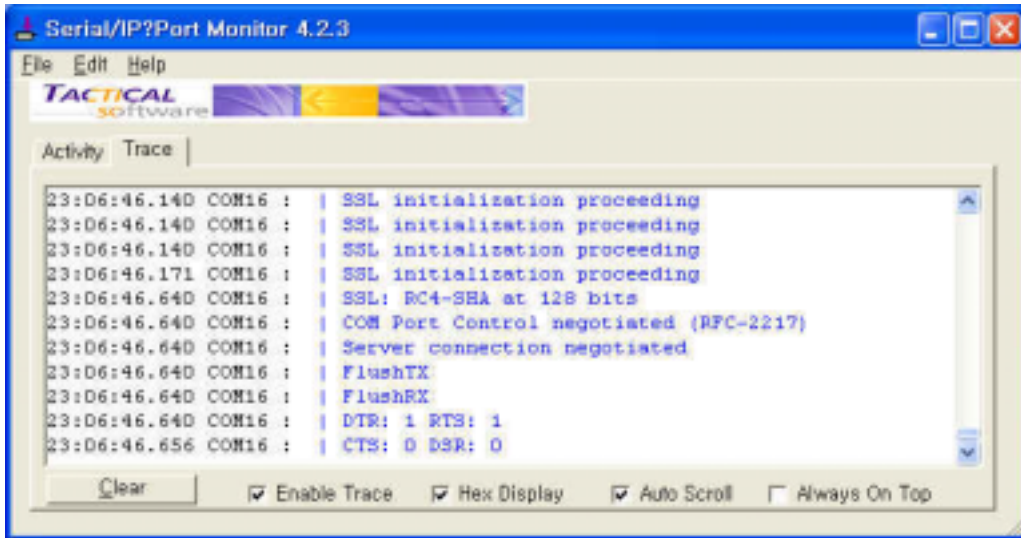

A-22 Serial/IP Trace Window

## 7. SSL

### A 7.1. OpenSSL

**Step 1.** Download the latest OpenSSL package. (<http://www.openssl.org>)

**Step 2.** Install the OpenSSL package.

<For Windows user>

Download OpenSSL for Windows binary file and run it.

(<http://www.slproweb.com/products/Win32OpenSSL.html>)

<For Linux user>

Download OpenSSL source code and compile it.

```
# cd /work/  
# tar -xvzf openssl-0.9.7d.tar.gz  
# cd openssl-0.9.7d  
# ./config  
# make  
# make test  
# make install
```

### A 7.2. root CA (for Self-signed)

**Step 1.** Editing openssl configuration file.

Default configuration file location is as follows,

< Windows >

C:\Program Files\OpenSSL\bin

< Linux >

/usr/share/ssl/openssl.cnf

Modify [req\_distinguished\_name] section as follows,

```
countryName           = Country Name (2 letter code)  
countryName_default   = KR  
countryName_min       = 2  
countryName_max       = 2  
  
stateOrProvinceName   = State or Province Name (full name)  
#stateOrProvinceName_default = Some-State  
  
localityName          = Locality Name(eg, city)  
localityName_default   = Seoul
```

```

0.organizationName      = Organization Name (eg, company)
0.organizationName_default = Sena Technologies Inc.

# we can do this but it is not needed normally :-)
#1.organizationName      = Second Organization Name (eg, company)
#1.organizationName_default = World Wide Web Pty Ltd

organizationalUnitName    = Organizational Unit Name (eg, section)
#organizationalUnitName_default =

commonName                = Common Name (eg, your name or your server\'s hostname)
commonName_default        = Sena Technologies
commonName_max            = 64

emailAddress              = Email Address
emailAddress_max          = 40

```

Modify [req\_attributes] section as follows,

```

challengePassword_min =0
challengePassword_max =0

```

## Step 2. Making self-signed Root CA(Certificate Authority)

< Windows >

```
# cd /work/openssl-0.9.7d/
```

< Linux >

```
# cd /work/openssl-0.9.7d/
```

```
# mkdir CA
```

```
# cd CA
```

```
# sh /usr/local/ssl/misc/CA.sh -newca
```

```

CA certificate filename (or enter to create)
  ;(Press Enter to use default value)
Making CA certificate ...
; openssl is called here as follow from CA.sh
; openssl req -new -x509 -keyout ./demoCA/private/./cakey.pem \
; -out ./demoCA/./cacert.pem -days 365
Using configuration from /usr/local/ssl/lib/ssl.cnf
Generating a 1024 bit RSA private key
.....+++++
.....+++++
writing new private key to './demoCA/private/./cakey.pem'
Enter PEM pass phrase:  ; CA Password (Enter password and remember this)
Verifying password - Enter PEM pass phrase:  ; CA Password
-----
You are about to be asked to enter information that will be incorporated
into your certificate request.
What you are about to enter is what is called a Distinguished Name or a DN.
There are quite a few fields but you can leave some blank
For some fields there will be a default value,
If you enter '.', the field will be left blank.
----- ; CA's Information
Country Name (2 letter code) [AU]: KR
State or Province Name (full name) [Some-State]:(Enter)
Locality Name (eg, city) []:Seoul
Organization Name (eg, company) [Internet Widgits Pty Ltd]: Sena Technologies
Organizational Unit Name (eg, section) [](Enter)
Common Name (eg, YOUR name) []:Sena Technologies

```

```
Email Address []:(Enter)
#
```

2-3. Check whether CA key file(demoCA/private/cakey.pem) and CA certificate (demoCA/cacert.pem) is generated

```
# ls demoCA/
cacert.pem  certs    crl  index.txt    newcerts
private    serial

# ls demoCA/private
cakey.pem
```

### A 7.3. (certificate request)

To make new certificates, you should make a certificate request first.

```
# cd /work/openssl-0.9.7c/CA
```

Run following commands,

```
# openssl genrsa -out key.pem 1024
# openssl req -new -key key.pem -out req.pem

(It is assumed that you are using sample configuration file
-“openssl.conf.sena”)
```

```
Using configuration from /usr/share/ssl/openssl.cnf
You are about to be asked to enter information that will be incorporated
into your certificate request.
What you are about to enter is what is called a Distinguished Name or a DN.
There are quite a few fields but you can leave some blank
For some fields there will be a default value,
If you enter '.', the field will be left blank.
-----
Country Name (2 letter code) [US]: (Enter)
State or Province Name (full name) [Minnesota]: (Enter)
Locality Name (eg, city) [Minneapolis]: (Enter)
Organization Name (eg, company) [Digi International]: (Enter)
Organizational Unit Name (eg, section) []:(Enter)
Common Name (eg, your name or your server's hostname) []:Sena VTS
Email Address []:(Enter)

Please enter the following 'extra' attributes
to be sent with your certificate request
A challenge password []:(Press Enter - Do not enter any other characters)
An optional company name []:(Press Enter - Do not enter any other characters)
```



## A 7.4. (certificate request)

### 4-1. Signing a certificate request

```
# cd /work/openssl-0.9.7c/CA
# cp req.pem newreq.pem
# sh /usr/local/ssl/misc/CA.sh -sign
```

```
Using configuration from /usr/share/ssl/openssl.cnf
Enter PEM pass phrase: CA Password (Enter CA password in step 2-2)
Check that the request matches the signature
Signature ok
The Subjects Distinguished Name is as follows
countryName       :PRINTABLE:'US'
stateOrProvinceName :PRINTABLE:'Minnesota'
localityName      :PRINTABLE:'Minneapolis'
organizationName  :PRINTABLE:'Digi International'
commonName        :PRINTABLE:'Digi PortServer CM'
Certificate is to be certified until Oct  6 09:39:59 2013 GMT (3653 days)
Sign the certificate? [y/n]:y

1 out of 1 certificate requests certified, commit? [y/n]:y
Write out database with 1 new entries
Data Base Updated
Certificate:
  Data:
    Version: 3 (0x2)
    Serial Number: 1 (0x1)
    Signature Algorithm: md5WithRSAEncryption
    Issuer: C=US, ST=Minnesota, L=Minneapolis, O=Digi International, CN=Digi International
    Validity
      Not Before: Oct  6 09:39:59 2013 GMT
      Not After : Oct  6 09:39:59 2013 GMT
    Subject: C=US, ST=Minnesota, L=Minneapolis, O=Digi International, CN=Digi PortServer CM
    Subject Public Key Info:
      Public Key Algorithm: rsaEncryption
      RSA Public Key: (1024 bit)
    ....
    -----BEGIN CERTIFICATE-----
    ....
    -----END CERTIFICATE-----
Signed certificate is in newcert.pem
```

### 4-2. Check whether signed certificate (newcert.pem) is generated.

```
# ls
```

```
demoCA      key.pem      newcert.pem  newreq.pem  req.pem
```

## A 7.5. SS

### 5-1. Removing headings in newcert.pem file

```
# cd /work/openssl-0.9.7c/CA
# cp newcert.pem server.pem
# vi server.pem
```

```
Certificate:
  Data:
    Version: 3 (0x2)
    Serial Number: 1 (0x1)
    Signature Algorithm: md5WithRSAEncryption
    Issuer: C=KR, ST=, L=Seoul, O=Sena Technologies Inc., CN= Sena
Technologies
    Validity
      Not Before: Oct  6 09:39:59 2003 GMT
      Not After : Oct  6 09:39:59 2013 GMT
    Subject: C=US, ST=Minnesota, L=Minneapolis, O=Digi International, CN=Digi
PortServer CM
    Subject Public Key Info:
      Public Key Algorithm: rsaEncryption
      RSA Public Key: (1024 bit)
....
== Removing above lines ==
-----BEGIN CERTIFICATE-----
....
-----END CERTIFICATE-----
```

### 5-2. Concatenating key.pem file to server.pem

```
# cat key.pem >> server.pem
```